

G
F
E
D
C
B
A

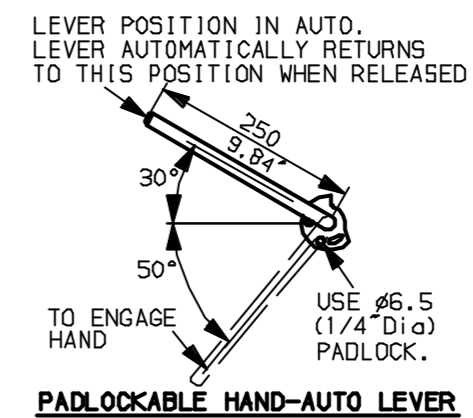

NOTES:
 * DIMENSIONS WITH '*' INDICATE COVER REMOVAL ALLOWANCE
 : NETT WEIGHT = 387kg (851 lbs)
 : = OIL FILLER/DRAIN PLUG
 : THE INTERFACE PROVIDED FOR MOUNTING THE ACTUATOR OR SECOND STAGE GEARBOX ONTO THE VALVE SHOULD CONFORM TO GOOD ENGINEERING PRACTICES, ENSURING ADEQUATELY TOLERANCED LIMITS FOR PARALLELISM, PERPENDICULARITY AND CONCENTRICITY.

CONDUIT ENTRIES (N.T.S)

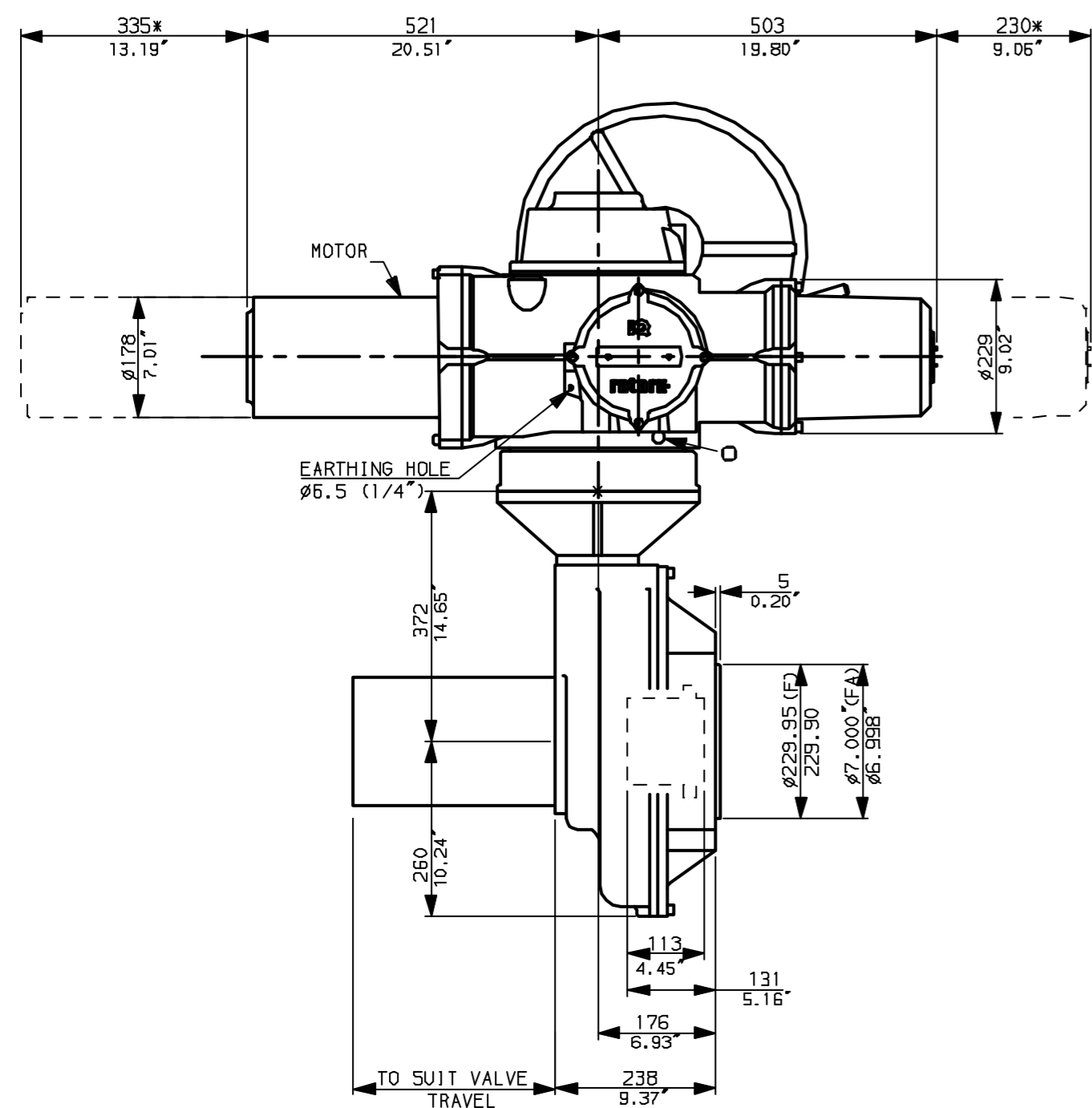
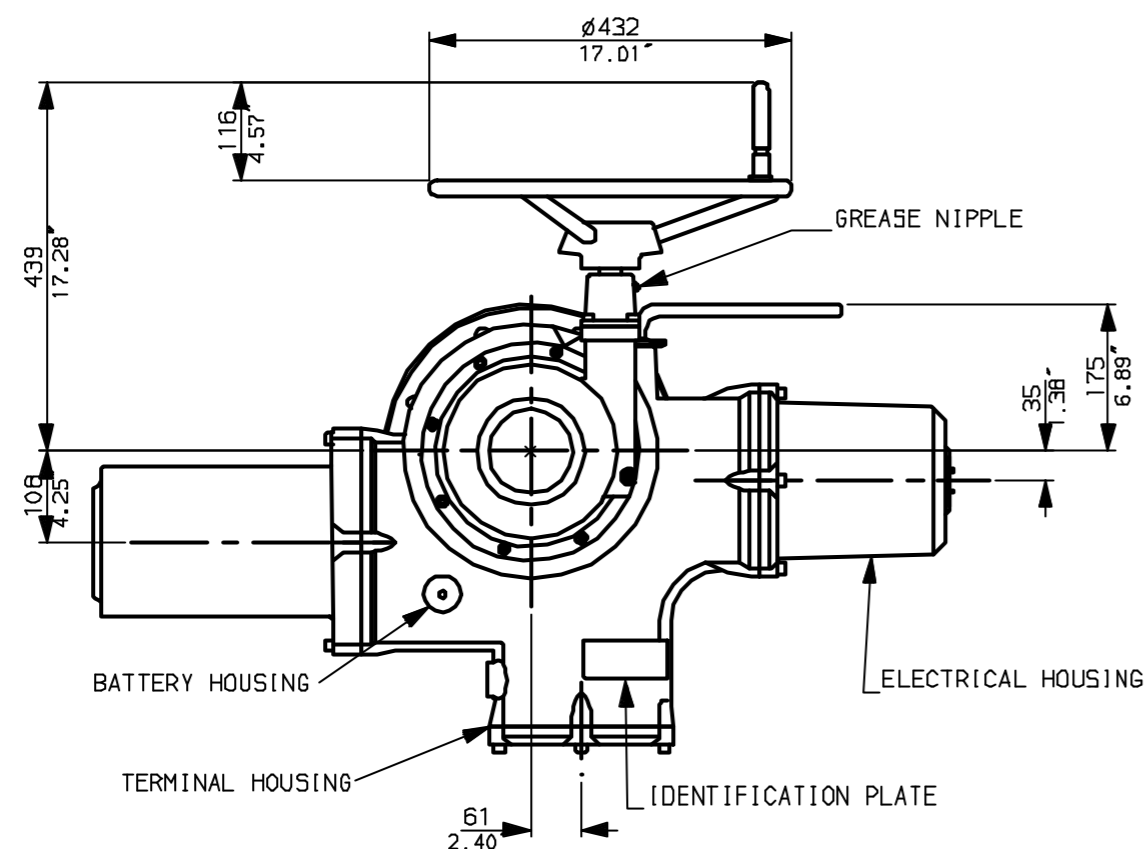
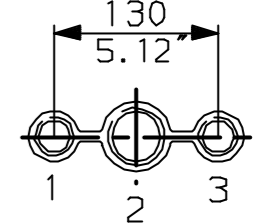

Nos.1 & 3 TAPPED 1" NPT
 No.2 TAPPED 1 1/2" NPT
 STD ALTERNATIVES IF SPECIFIED
 2 X M25, 1 X M40
 2 X PG16, 1 X PG29

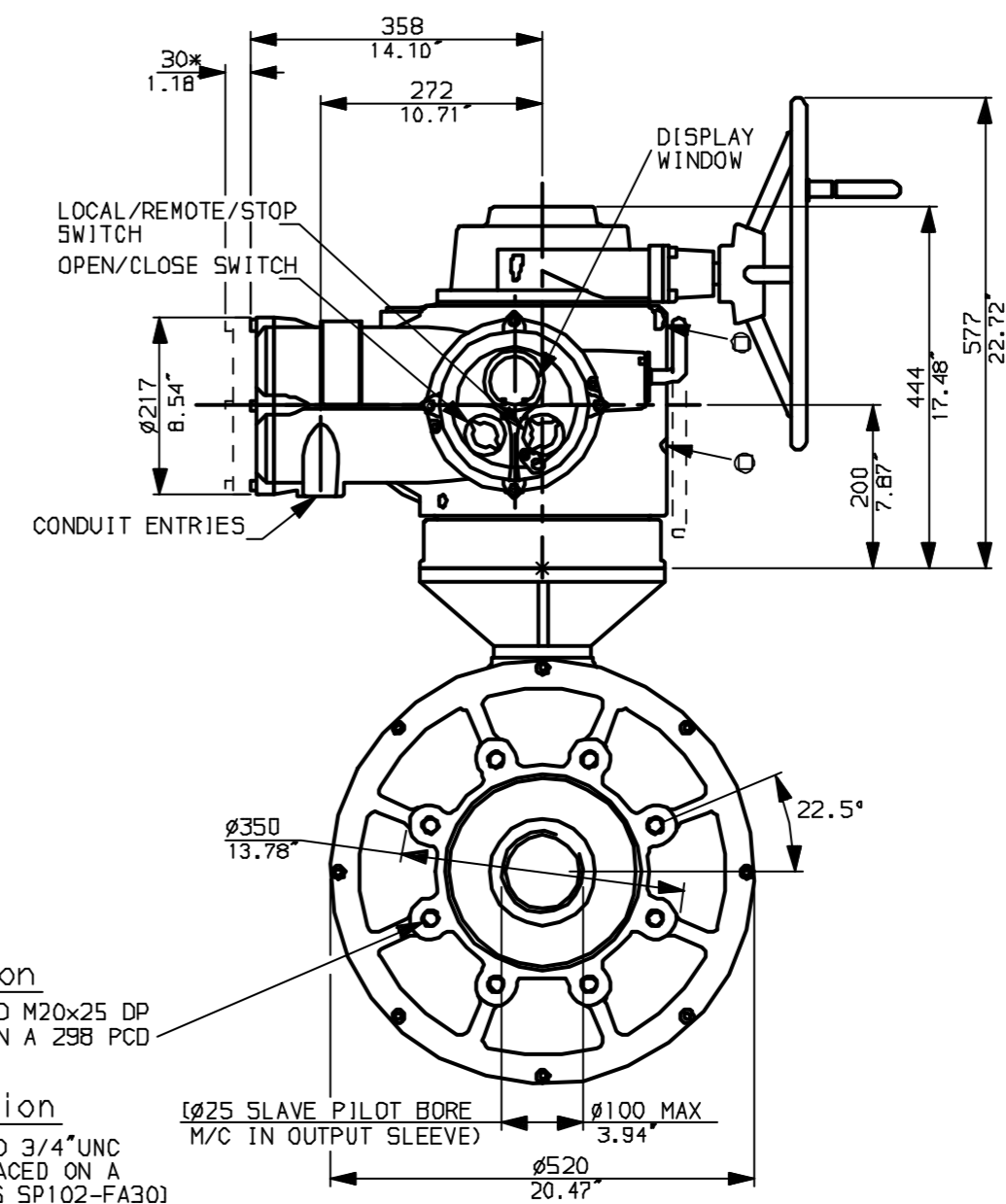

"F" version
 8 HOLES TAPPED M20x25 DP
 EQUI-SPACED ON A 298 PCD
 (ISO5210 F30)
 "FA" version
 8 HOLES TAPPED 3/4" UNC
 x1" dp EQUI-SPACED ON A
 11.75" PCD (M55 SP102-FA30)



Rotork Controls Ltd.
 Bath England, BA1 3JQ.
 (Phone 01225-733200)
 Rotork Controls Inc.
 Rochester, NY 14624
 (Phone 585-328-1550)

Title IQ70, 90, SHW, IB12,		
STANDARD DIMENSIONAL DATA		
Drawn CAD	Checked PRE	Ref Data Sheet
Date April 04	Job No IQ55HW_IB12	

01	First Issue.
Scale 1:9	THIRD ANGLE PROJECTION
Drawing Number	IQ55HW_IB12

1 | 2 | 3 | 4 | 5 | 6 | 7 | 8 | 9 | 10

G
F
E
D
C
B
A

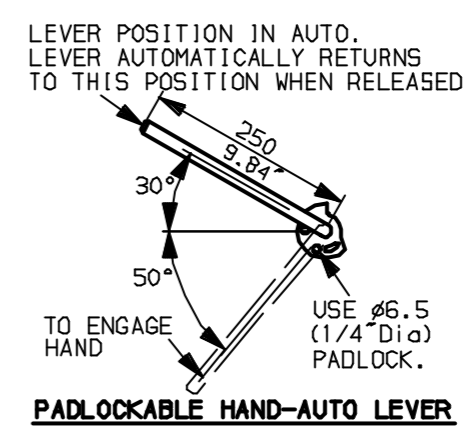
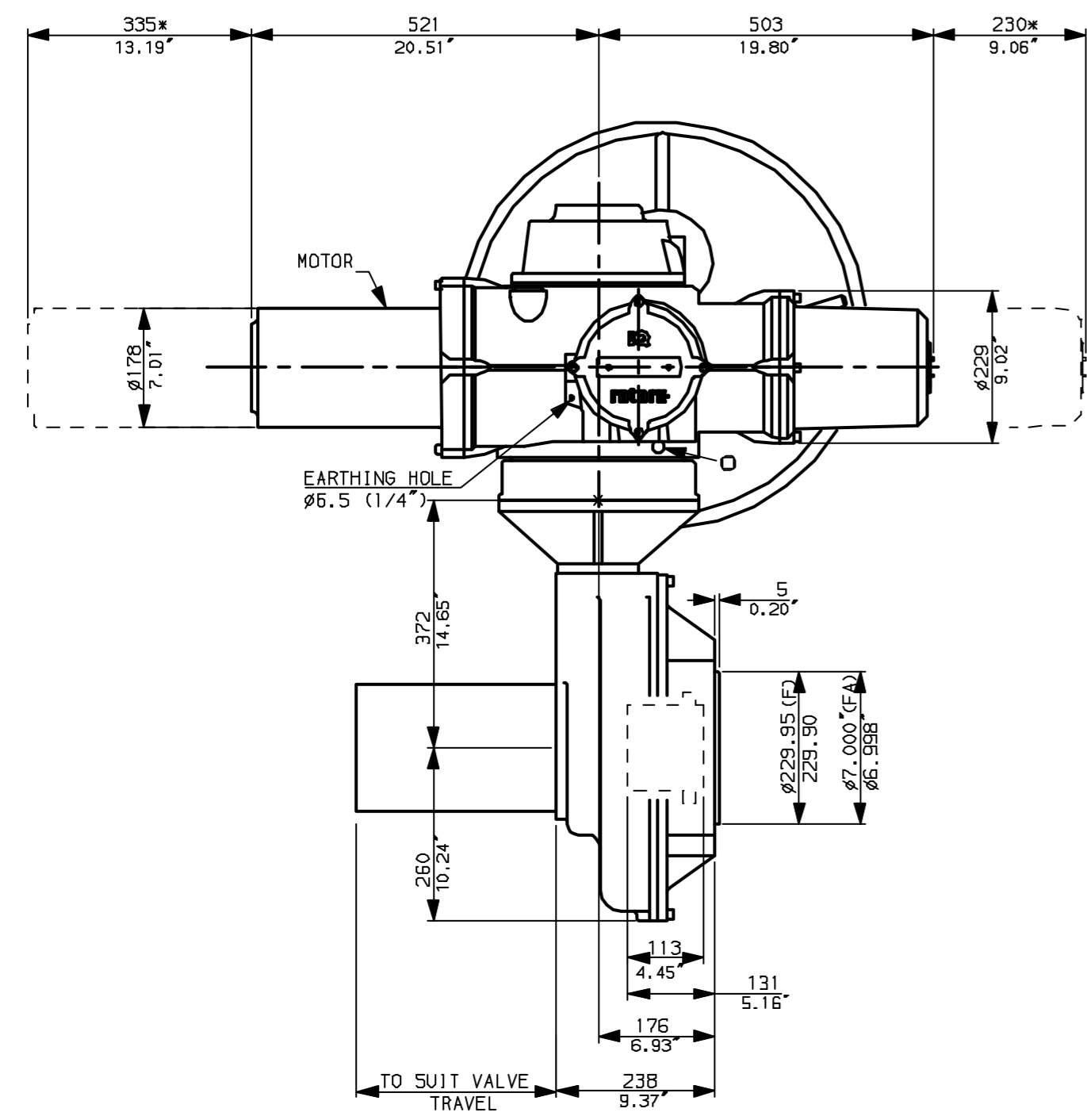
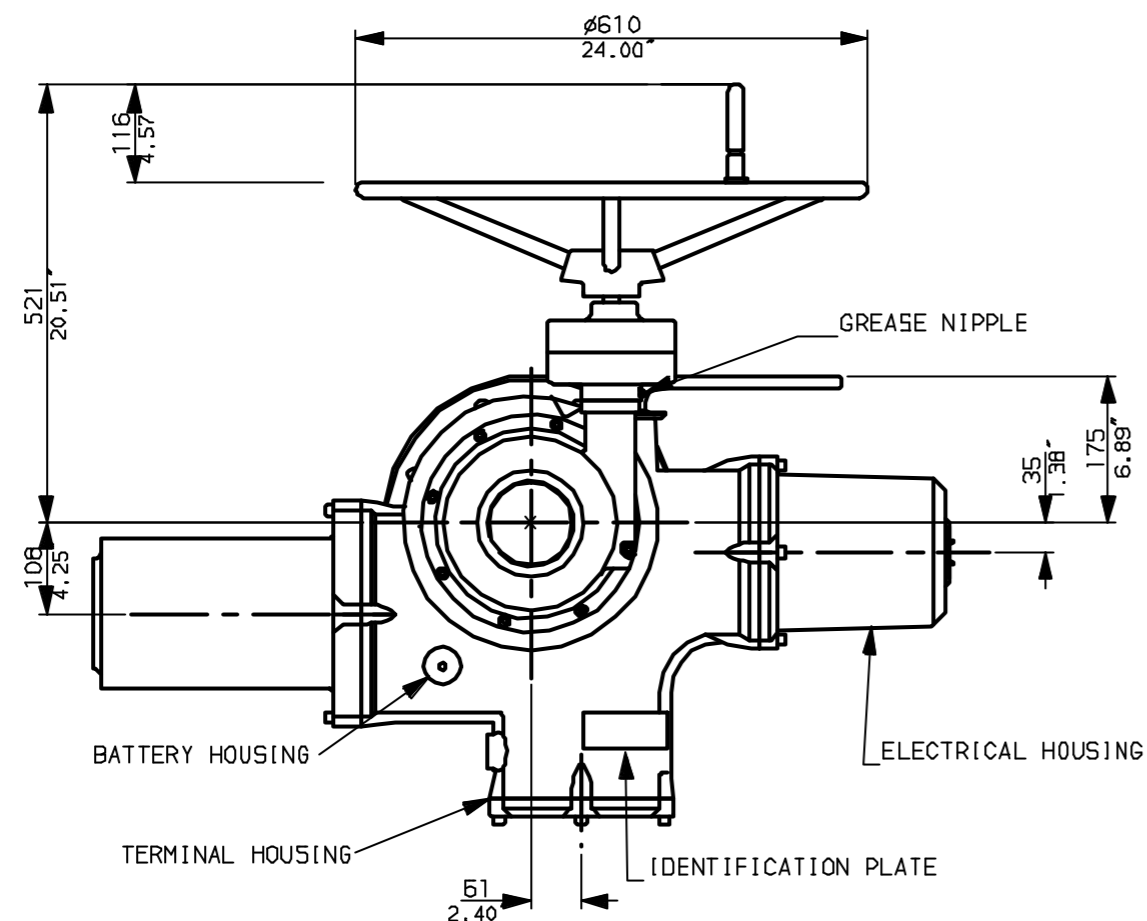

NOTES:
 DIMENSIONS WITH '' INDICATE COVER REMOVAL ALLOWANCE
 :NETT WEIGHT = 387kg (851 lbs)
 : \odot = OIL FILLER/DRAIN PLUG
 :THE INTERFACE PROVIDED FOR MOUNTING THE ACTUATOR OR SECOND STAGE GEARBOX ONTO THE VALVE SHOULD CONFORM TO GOOD ENGINEERING PRACTICES, ENSURING ADEQUATELY TOLERANCED LIMITS FOR PARALLELISM, PERPENDICULARITY AND CONCENTRICITY.

CONDUIT ENTRIES (N.T.S)

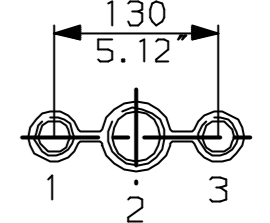

Nos.1 & 3 TAPPED 1" NPT
 No.2 TAPPED 1 1/2" NPT
 STD ALTERNATIVES IF SPECIFIED
 2 X M25, 1 X M40
 2 X PG16, 1 X PG29

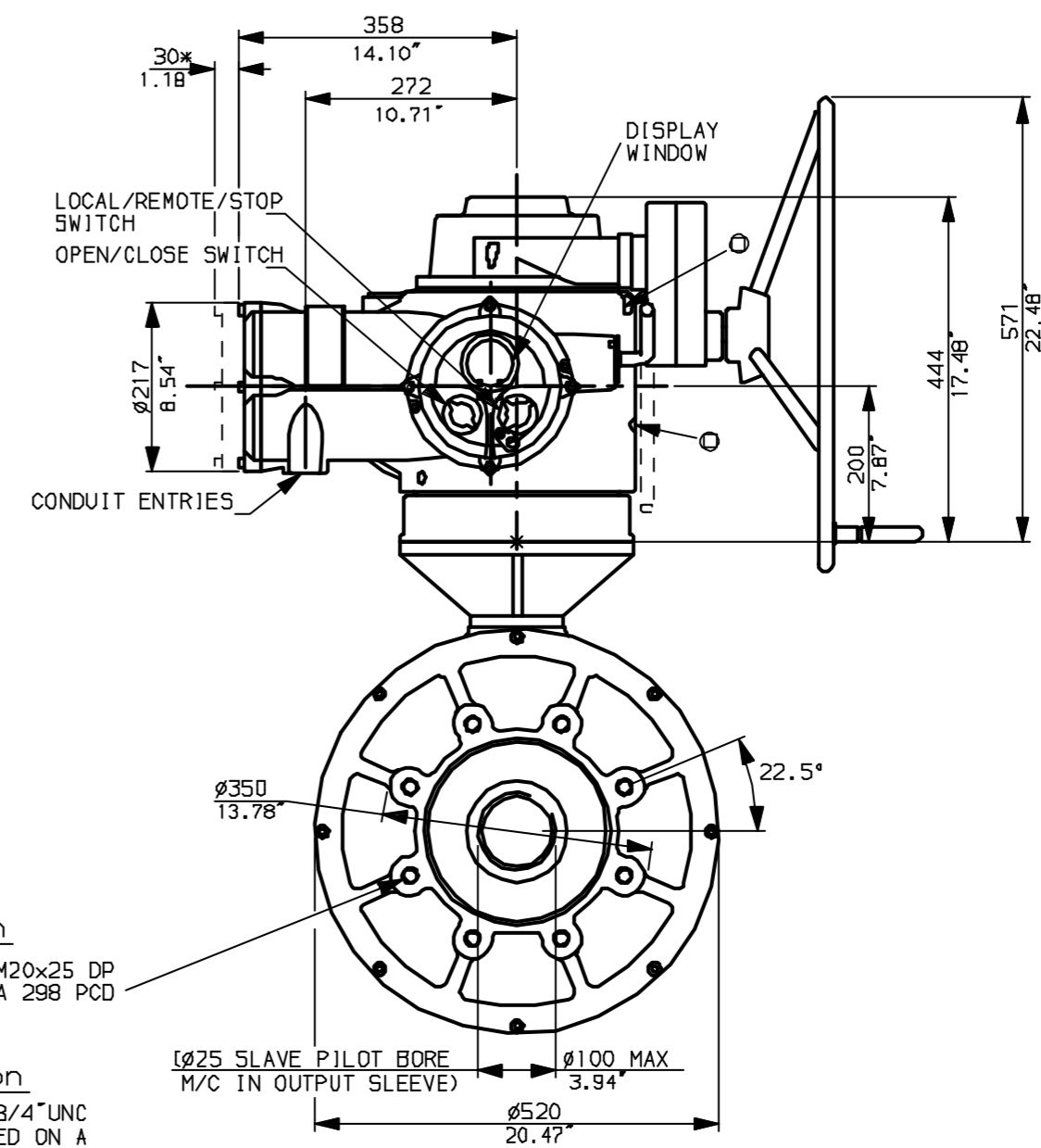

"F" version
 8 HOLES TAPPED M20x25 DP
 EQUI-SPACED ON A 298 PCD
 (1S05210 F30)
 "FA" version
 8 HOLES TAPPED 3/4"UNC
 x1"dp EQUI-SPACED ON A
 11.75"PCD (M55 SP102-FA30)

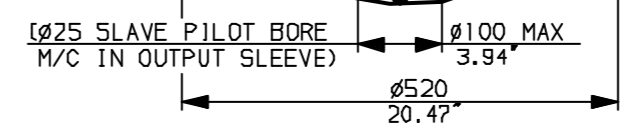

Rotork Controls Ltd.
 Bath England, BA1 3JQ.
 (Phone 01225-733200)
 Rotork Controls Inc.
 Rochester, NY 14624
 (Phone 585-328-1550)

Title IQ70, 90, SSHW, IB12,		
STANDARD DIMENSIONAL DATA		
Drawn CAD	Checked PRE	Ref Data Sheet
Date April 04	Job No	IQ5SSHW_IB12

01	First Issue.
Scale	1:9 THIRD ANGLE PROJECTION
Drawing Number	IQ5SSHW_IB12

1 | 2 | 3 | 4 | 5 | 6 | 7 | 8 | 9 | 10