

GEARBOX HAS BEEN DELIVERED IN OPEN POSITION AS SHOWN

- PLACE INDICATOR(1) ON QUADRANT
- USE THE TWO SCREWS(2) TO MOUNT THE INDICATOR ONTO THE QUADRANT
- PLACE THE LABEL(3) AS SHOWN ONTO THE GEARBOX.
- PRESS THE NUTCAPS(4) ONTO THE STUDBOLT NUTS

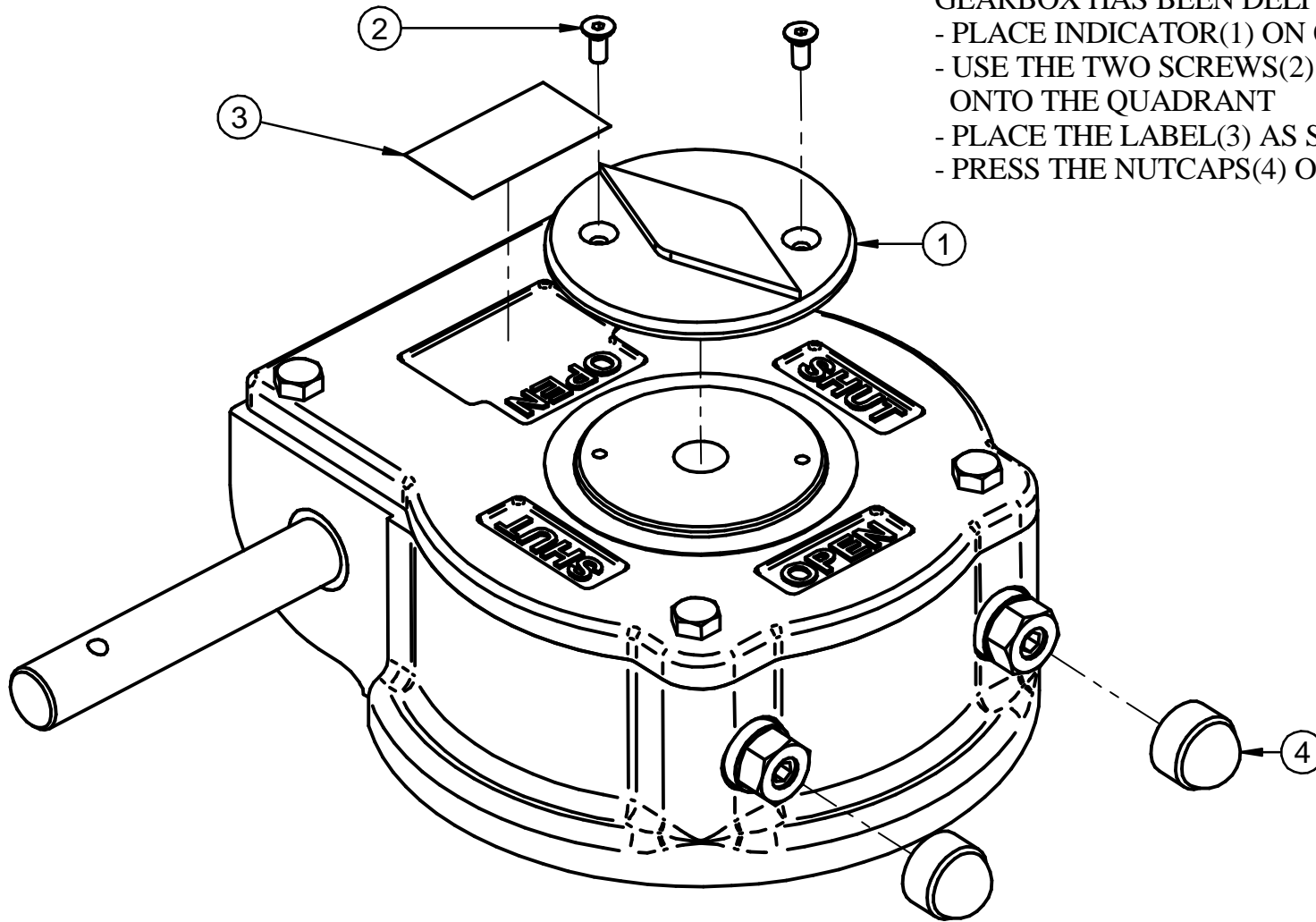

ITEM	Title	Material	Quantity
1	POSITION INDICATOR	Aluminum	1
2	COUNTERSUNK SOCKET HEAD SCREW	STAINLESS STEEL A4 GRADE 70	2
3	LABEL		1
4	NUTCAP	LDPE	2

REMOVE ALL SHARP EDGES		MADE FROM : -	
Material :	Art. nr. : ASM-PAINTPARTS	Note :	
TITLE OF DRAWING : ASSEMBLING PARTS AFTER PAINTING	IF NOT MENTIONED ON THE DRAWING : TOLERANCE acc. DIN 7168 part.1 (mm)		DATE : 19-5-2011
	0 TO 6 ±0.10	120 TO 400 ±0.50	DRAWN: niels middel
6 TO 30 ±0.20	400 TO 1000 ±0.80	APPROVED: Henk Hoff	
30 TO 120 ±0.30	1000 TO 2000 ±1.20		
rotork ® Gears	DIMENSIONS IN MM	NEW DRAWING NR. : ASM-PAINTPARTS	REV.: 00
	SCALE : NONE		

THIS DOCUMENT IS PROPERTY OF ROTORK GEARS BV. NEITHER THIS OR ITS CONTENT MAY BE COPIED OR USED IN ANY OTHER WAY DETRIMENTAL TO THE INTEREST OF ROTORK GEARS BV. ACCEPTANCE OF THIS DOCUMENT SHALL CONSTITUTE ACKNOWLEDGEMENT OF THE FOREGOING CONDITIONS