

ISOMETRIC VIEW
(SCALE 1:20)

NOTES:
 :DIMENSIONS WITH "*" INDICATE COVER REMOVAL ALLOWANCE
 :NETT WEIGHT = 568kg/1252lbs
 : = OIL FILLER/DRAIN PLUG
 :THE INTERFACE PROVIDED FOR MOUNTING THE ACTUATOR OR SECOND STAGE GEARBOX ONTO THE VALVE SHOULD CONFORM TO GOOD ENGINEERING PRACTICES, ENSURING ADEQUATELY TOLERANCED LIMITS FOR PARALLELISM, PERPENDICULARITY AND CONCENTRICITY.
 :ROTORK CANNOT BE HELD LIABLE FOR DAMAGE TO OUR EQUIPMENT CAUSED BY EXCESSIVE LOADING FROM COVER TUBES. (SEE ALSO PUB000-124)

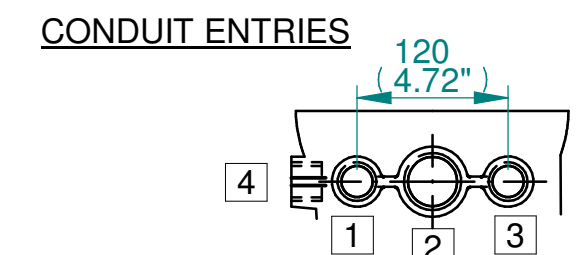

	Hole 1	Hole 2	Hole 3	Hole 4
Size	As Required	As Required	As Required	As Required
Plugged	As Required	As Required	As Required	As Required
Gland	As Required	As Required	As Required	As Required

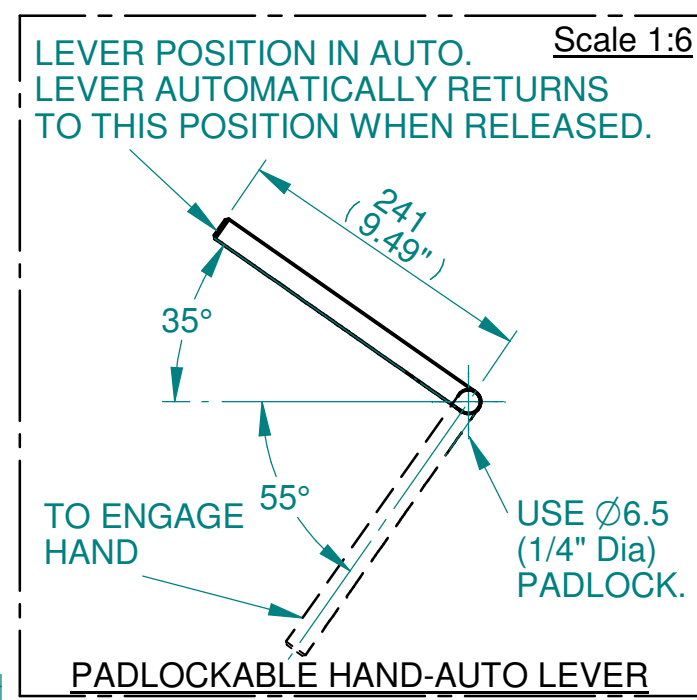
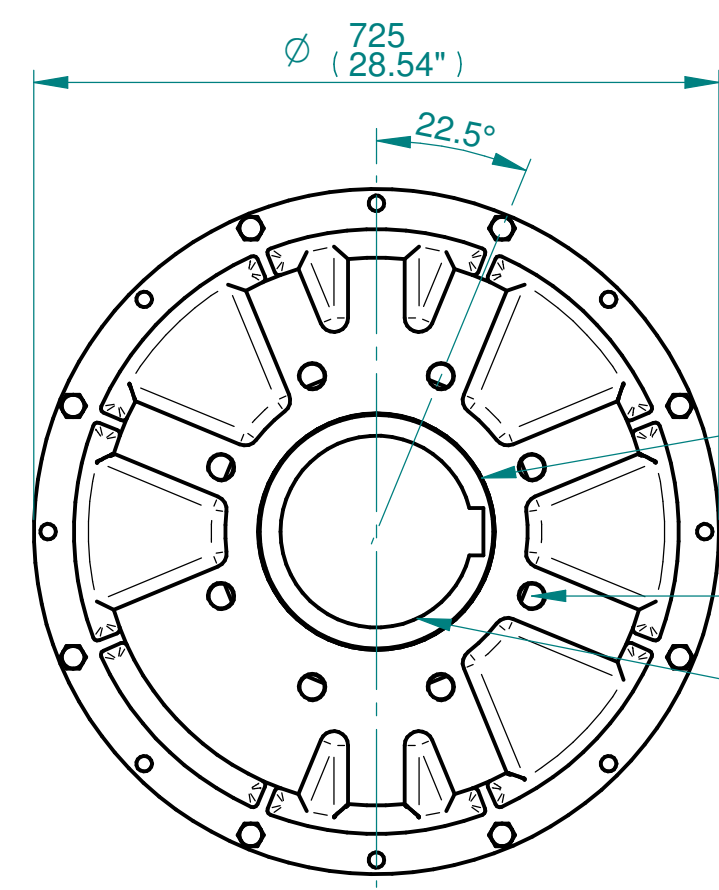
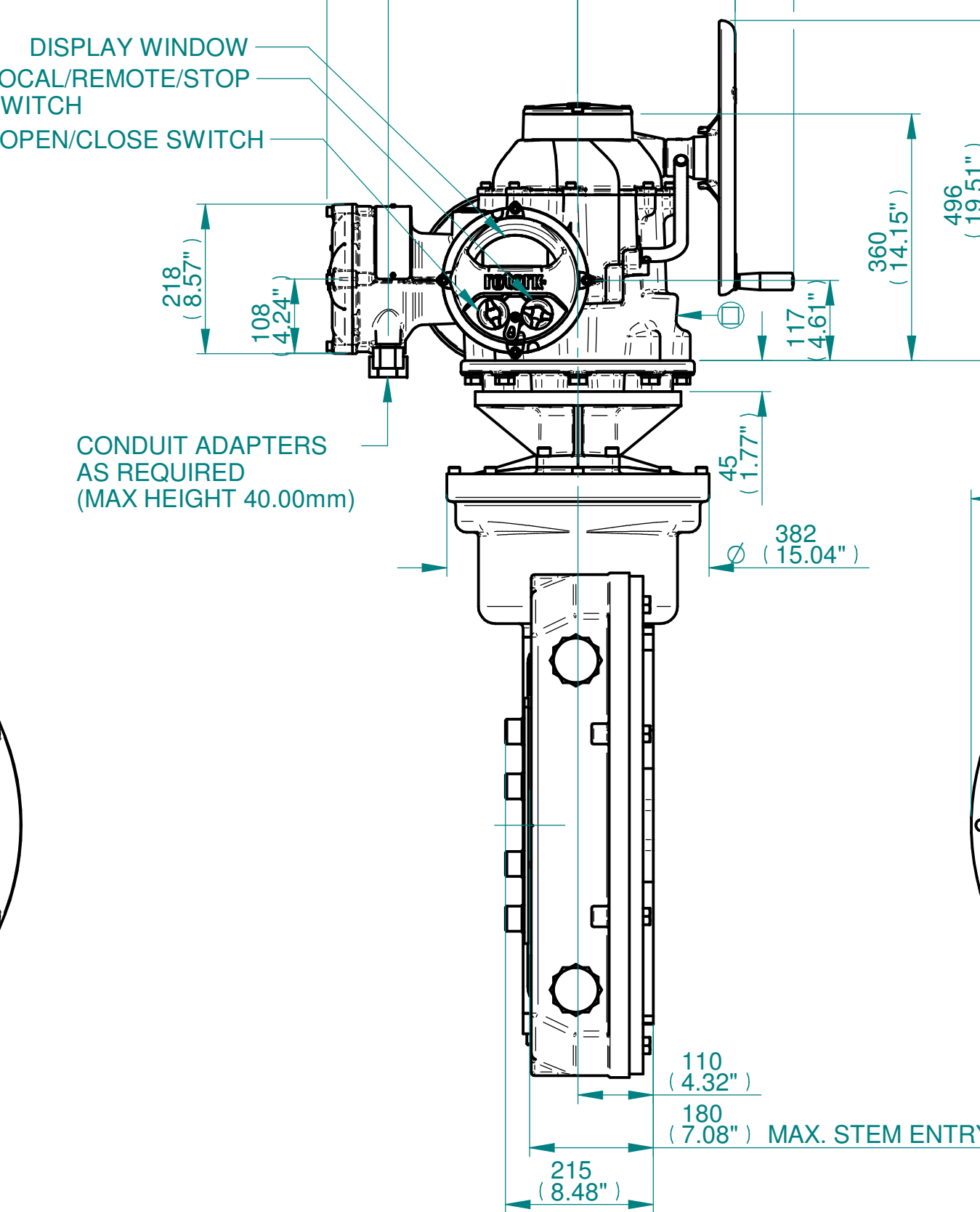
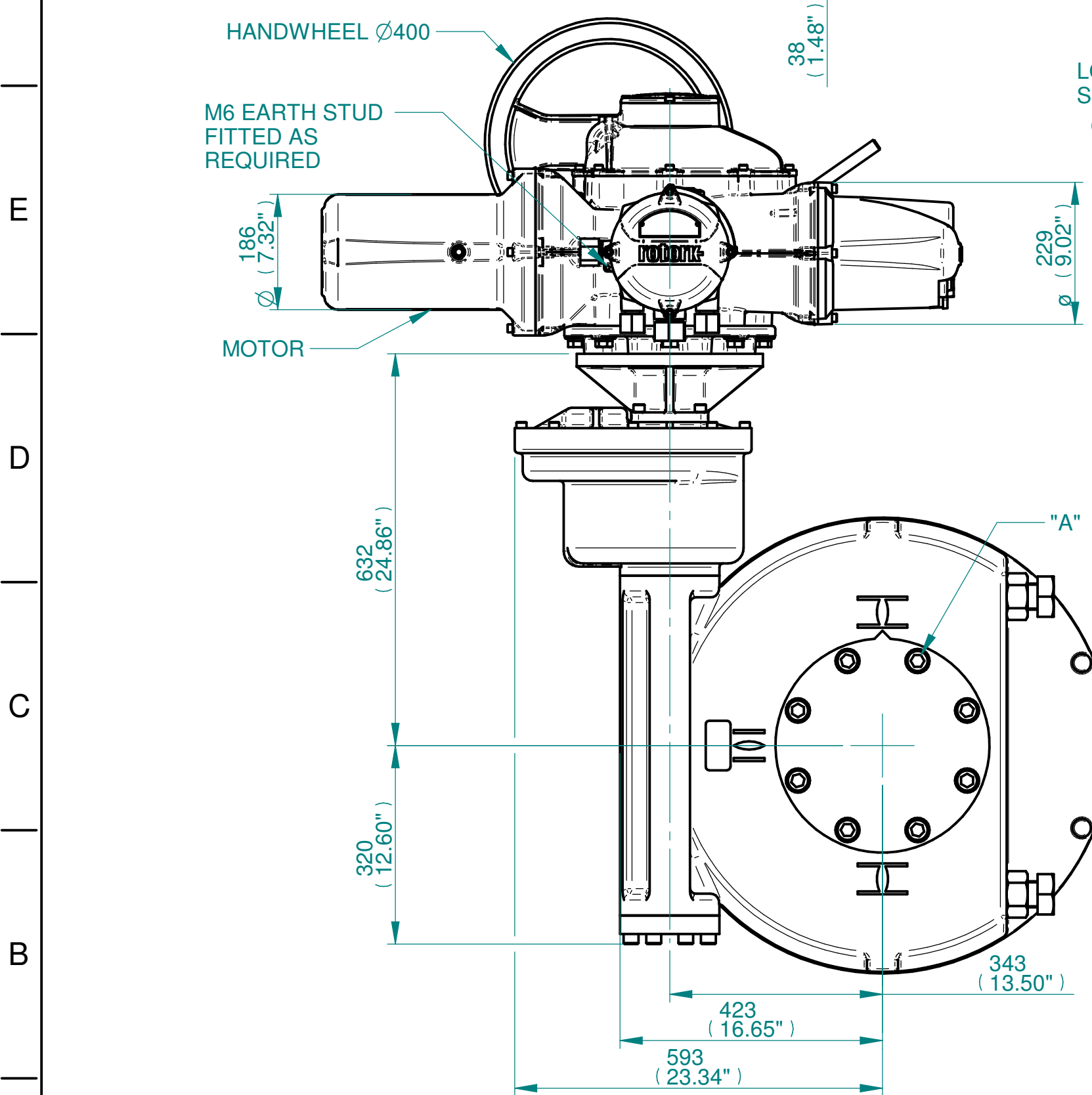

N.B. KEYWAY POS. CAN BE MOVED IN 45° STEPS BY REMOVING 8 SCREWS MARKED "A" AND ROTATING OUTPUT SLEEVE
 SEE GEARBOX OUTPUT FLANGE OPTIONS TABLE
 SEE MAXIMUM BORE & KEY TABLE

3D Models are available in various formats under the same drawing number

Actuator Size: IQ70/90/95 IW10R/MOW10R		Gearbox output flange options								Maximum Bore & Key			
rotork www.rotork.com Rotork Controls Limited Bath, BA1 3JQ, England. Telephone 01225-733200	Title IQ70/90/95, SIDE HANDWHEEL, IW10/MOW10RR, F35/F40/FA35/FA40, Ratios 180:1 - 3000:1 Installation Details	Designation	F35	F40	-	-	FA35	FA40	-	-	Key form	Ø Bore	Key size
	Drawn TED Checked NJC Date 18-AUG-14	No. Holes	8	8	-	-	8	8	-	-	Rectangle (BS4235)	203	50 X 28
	Ref SALES Project Ref QUOTATION	Hole size	M30	M36	-	-	1" UNC	1-1/4" UNC	-	-	Rectangle (ANSI B17.1)	7-5/8"	2 X 1-1/2"
		PCD	356	406	-	-	14"	16"	-	-	Square (ANSI B17.1)	7-3/8"	1-3/4" SQ

Issue	Description
2	4 ENTRY CHANGE

Scale: 1:8 THIRD ANGLE PROJECTION

Drawing Number	Issue No	Sheet No
I15SHWIW10RSTD	2	1 of 1