

H
G
F
E
D
C
B
A

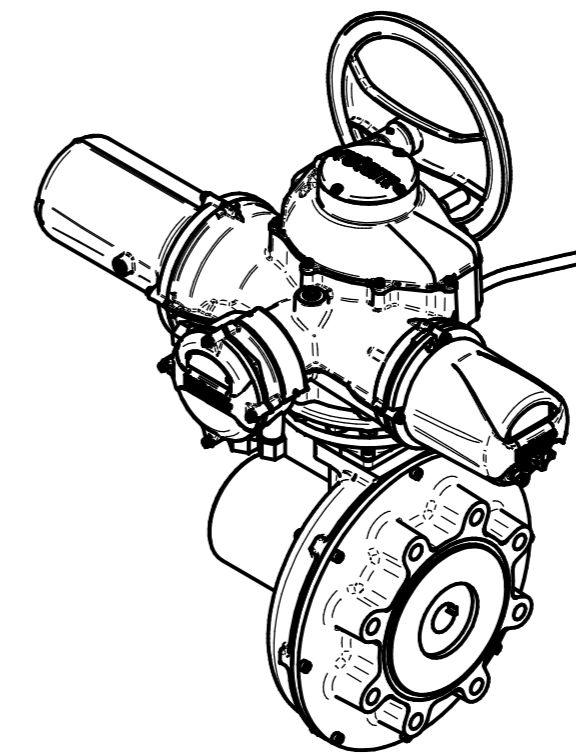
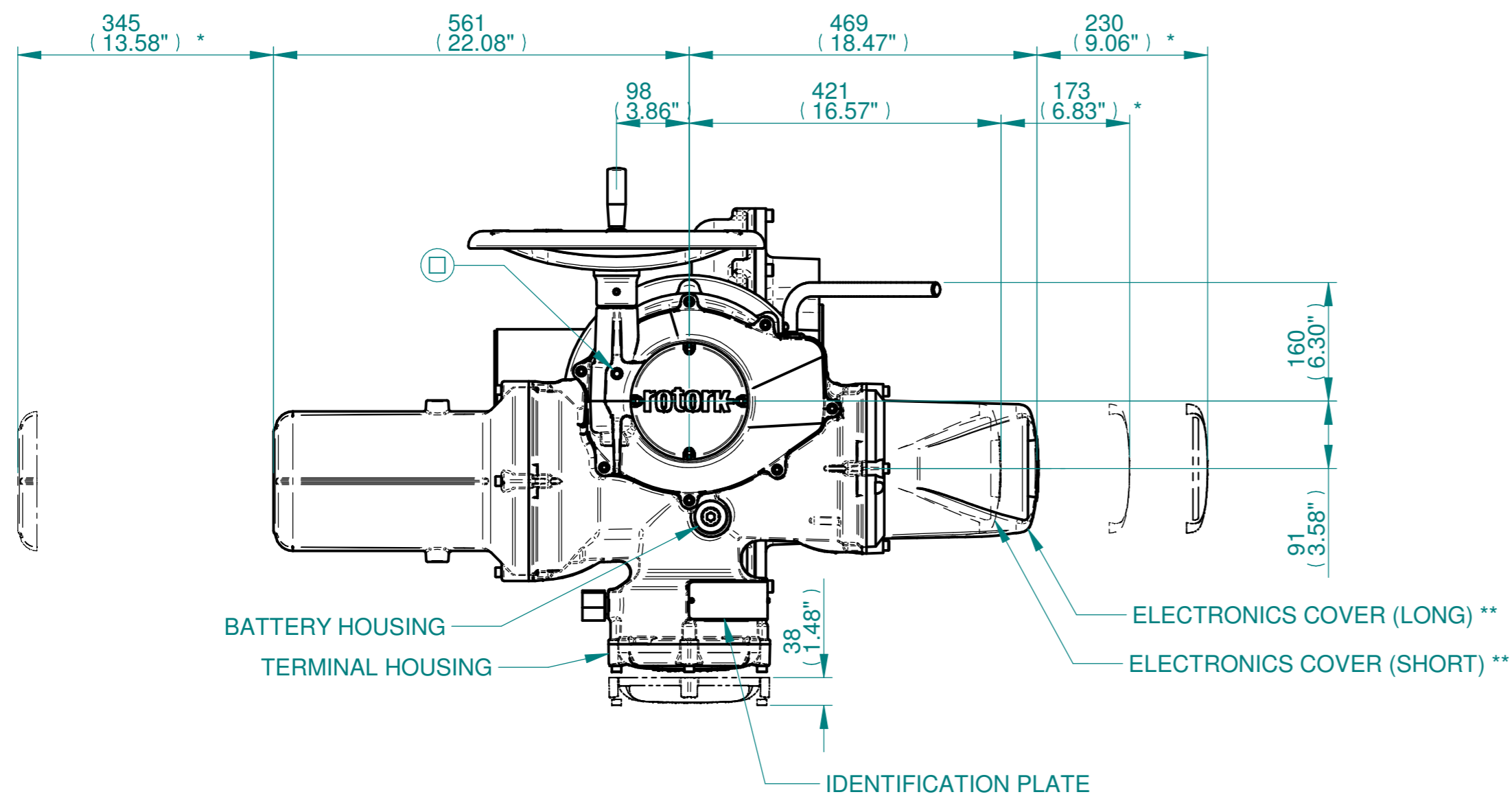

ISOMETRIC VIEW (SCALE 1:12)

NOTES:
 :DIMENSIONS WITH "*" INDICATE COVER REMOVAL ALLOWANCE
 :ELECTRONICS COVER OPTION "****" WILL VARY DEPENDING ON CONFIGURATION
 :NETT WEIGHT = F30:332kg/732lbs, F35:340kg/750lbs
 : = OIL FILLER/DRAIN PLUG
 :THE INTERFACE PROVIDED FOR MOUNTING THE ACTUATOR OR SECOND STAGE GEARBOX ONTO THE VALVE SHOULD CONFORM TO GOOD ENGINEERING PRACTICES, ENSURING ADEQUATELY TOLERANCED LIMITS FOR PARALLELISM, PERPENDICULARITY AND CONCENTRICITY.
 :ROTORK CANNOT BE HELD LIABLE FOR DAMAGE TO OUR EQUIPMENT CAUSED BY EXCESSIVE LOADING FROM COVER TUBES. (SEE ALSO PUB000-124)

CONDUIT ENTRIES

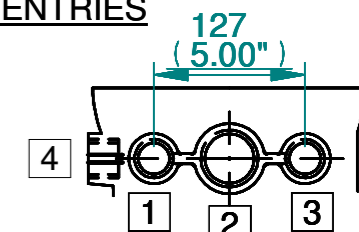

Size	Hole 1	Hole 2	Hole 3	Hole 4
Plugged	As Required	As Required	As Required	As Required
Gland	As Required	As Required	As Required	As Required

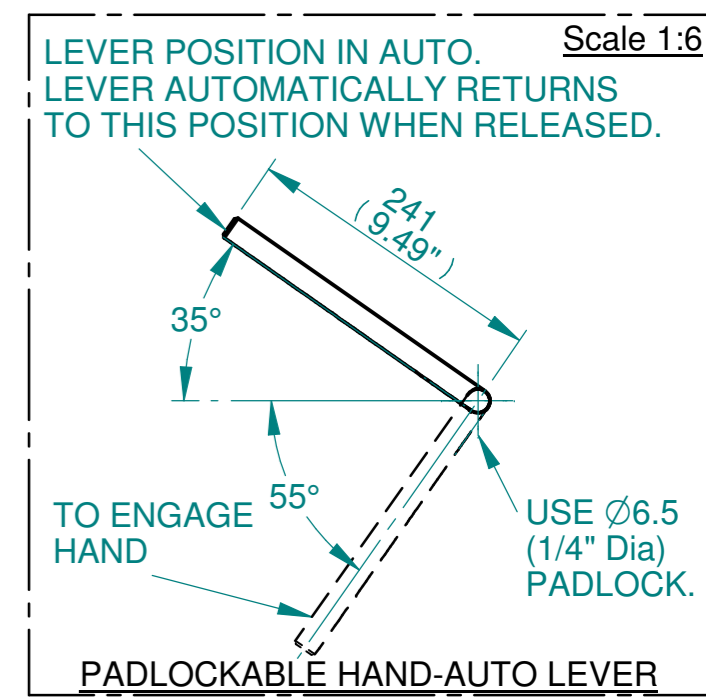
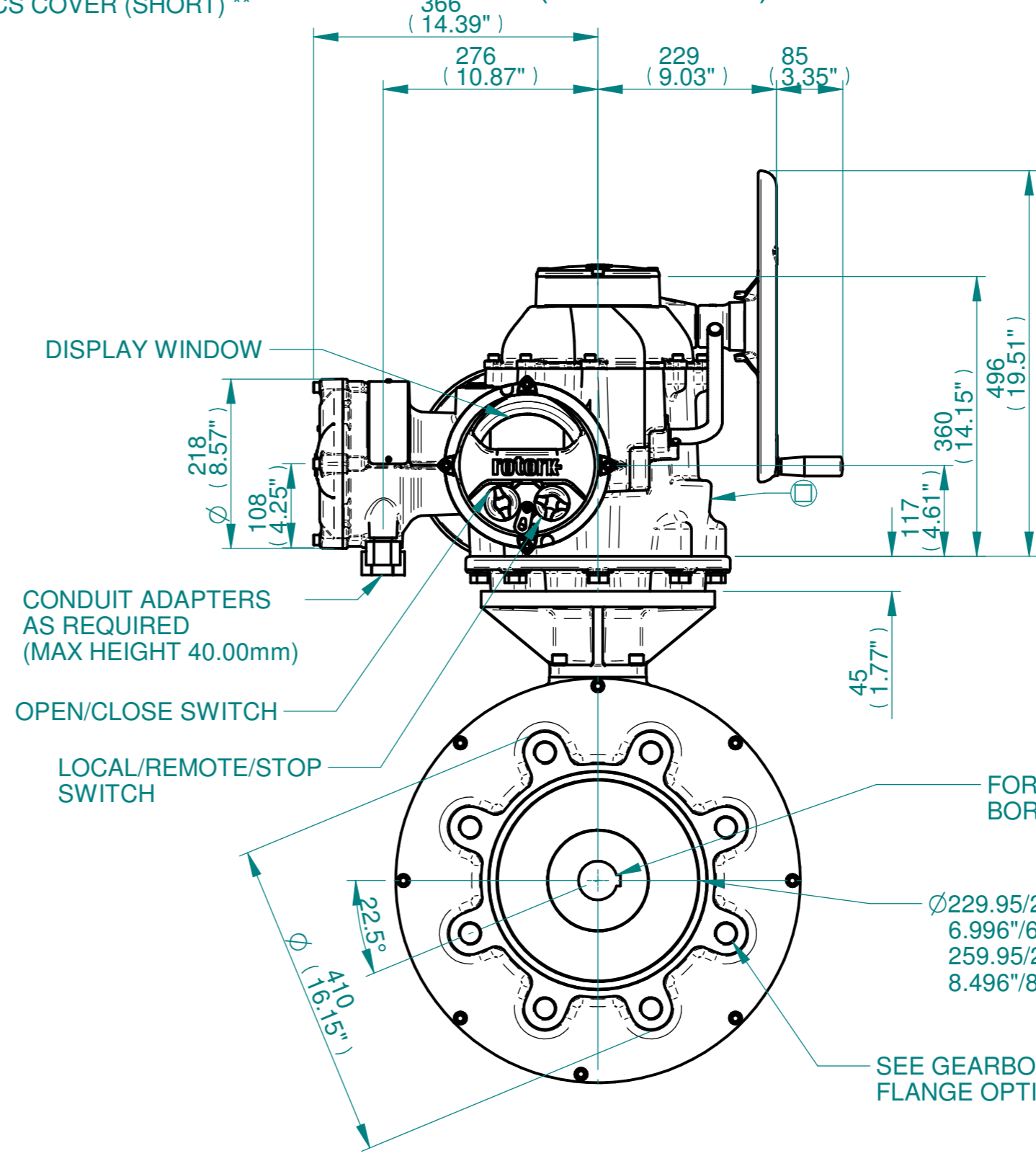
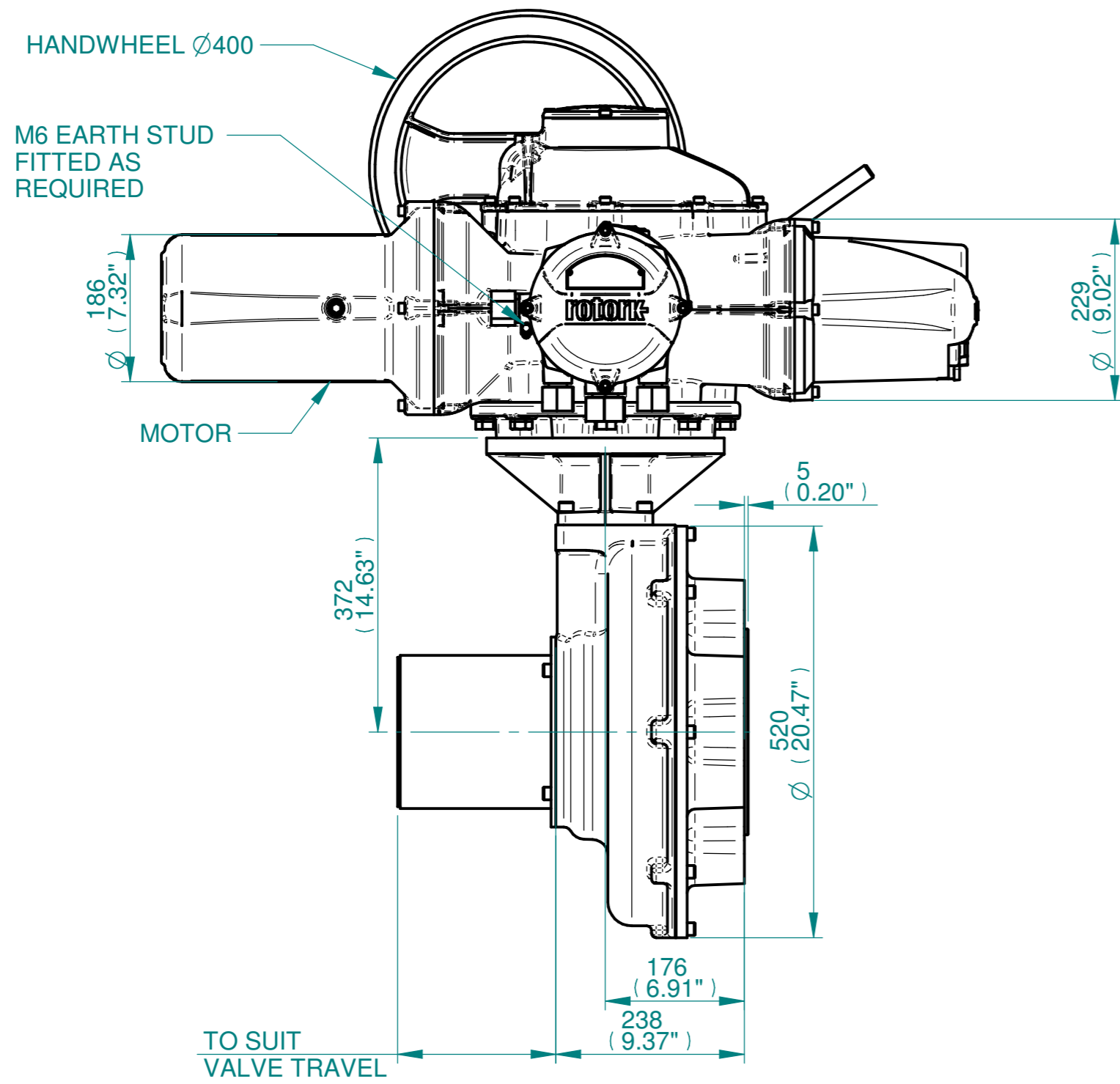

Scale 1:6



Rotork Controls Limited
 Bath, BA1 3JQ, England.
 Telephone 01225-733200

Actuator Size: IQ70/90/95, IB12, F30/F35/FA30/FA35		Gearbox output flange options								Maximum Bore & Key			
Title	IQ70/90/95, SIDE HANDWHEEL, IB12, F30/F35/FA30/FA35 Ratios 4:1 & 6:1 Installation Details	Designation	F30	F35	-	-	FA30	FA35	-	-	Key form	Ø Bore	Key size
Drawn	TCE	No. Holes	8	8	-	-	8	8	-	-	Rectangle (BS4235)	96	28 X 16
Checked	NJC	Hole size	M20	M30	-	-	3/4" UNC	1" UNC	-	-	Rectangle (ANSI B17.1)	3-3/4"	7/8 X 5/8"
Date	19-AUG-14	PCD	298	356	-	-	11.75"	14"	-	-	Square (ANSI B17.1)	3-1/2"	7/8"
Ref	SALES	Project Ref	QUOTATION										

Issue	Description
2	4 ENTRY CHANGE

Scale: 1:5 THIRD ANGLE PROJECTION

Drawing Number	Issue No	Sheet No
I15SHWIB12STD	2	1 of 1

1 2 3 4 5 6 7 8 9 10 11 12