

H  
G  
F  
E  
D  
C  
B  
A

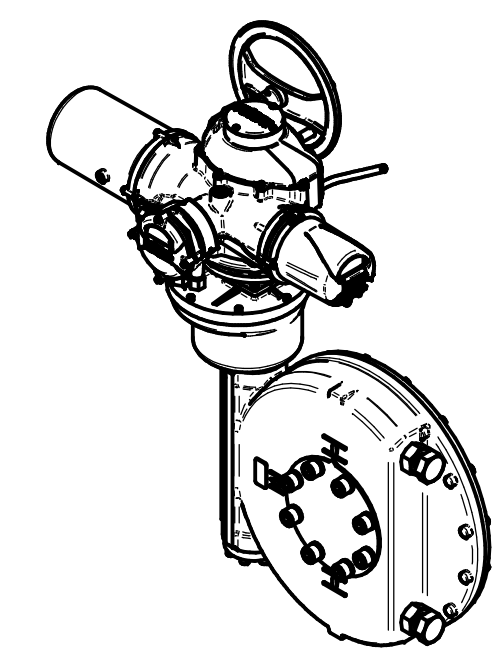

ISOMETRIC VIEW (SCALE 1:20)

**NOTES:**  
 : DIMENSIONS WITH "\*" INDICATE COVER REMOVAL ALLOWANCE  
 : NETT WEIGHT = 691kg/1523lbs  
 : = OIL FILLER/DRAIN PLUG  
 : THE INTERFACE PROVIDED FOR MOUNTING THE ACTUATOR OR SECOND STAGE GEARBOX ONTO THE VALVE SHOULD CONFORM TO GOOD ENGINEERING PRACTICES, ENSURING ADEQUATELY TOLERANCED LIMITS FOR PARALLELISM, PERPENDICULARITY AND CONCENTRICITY.  
 : ROTORK CANNOT BE HELD LIABLE FOR DAMAGE TO OUR EQUIPMENT CAUSED BY EXCESSIVE LOADING FROM COVER TUBES. (SEE ALSO PUB000-124)

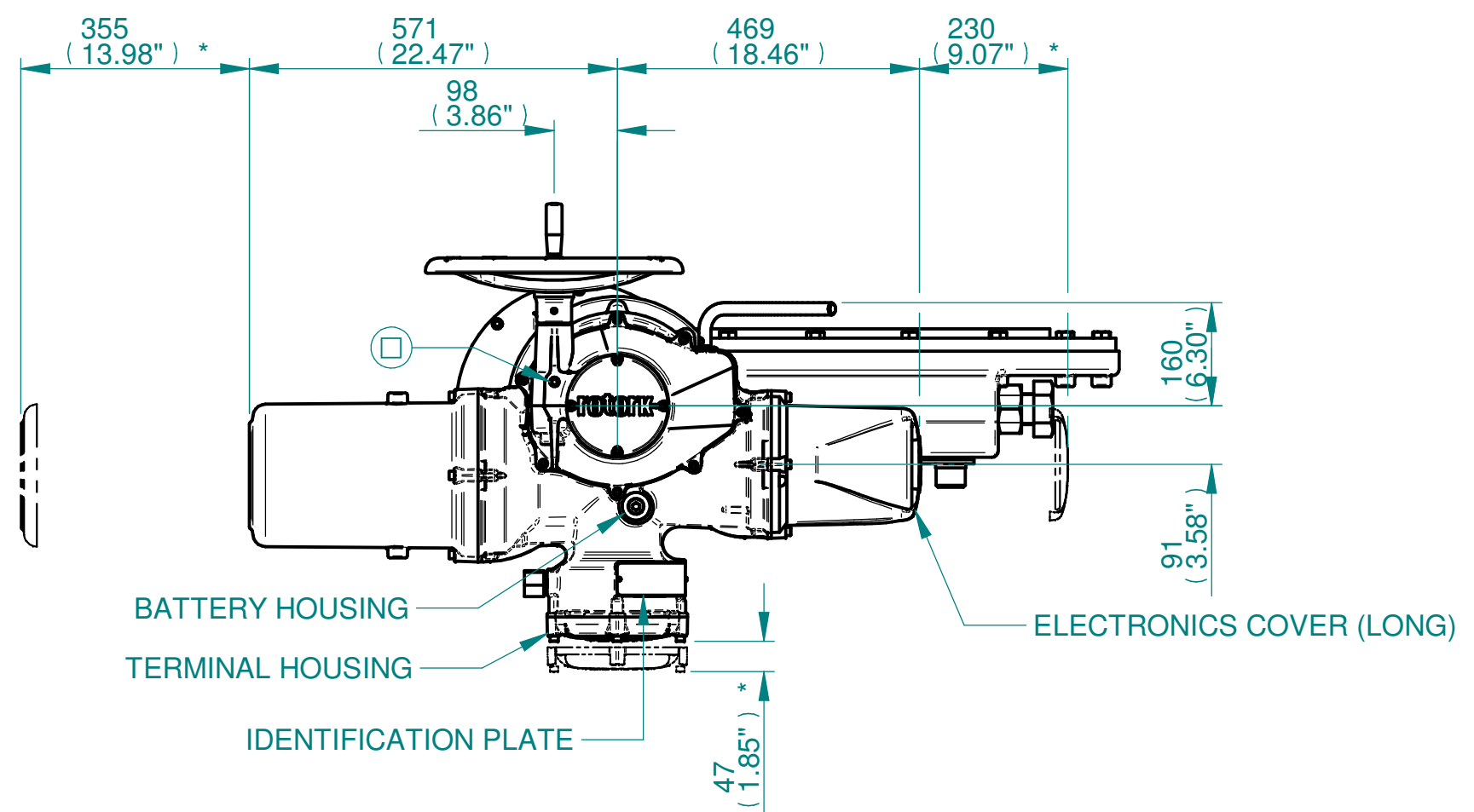
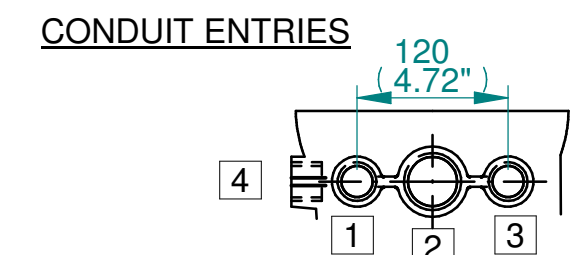

	Hole 1	Hole 2	Hole 3	Hole 4
Size	As Required	As Required	As Required	As Required
Plugged	As Required	As Required	As Required	As Required
Gland	As Required	As Required	As Required	As Required

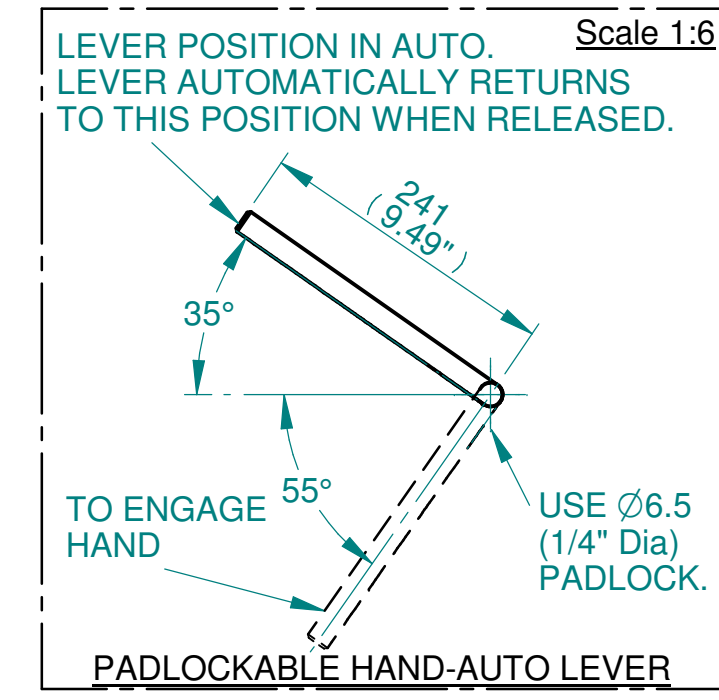
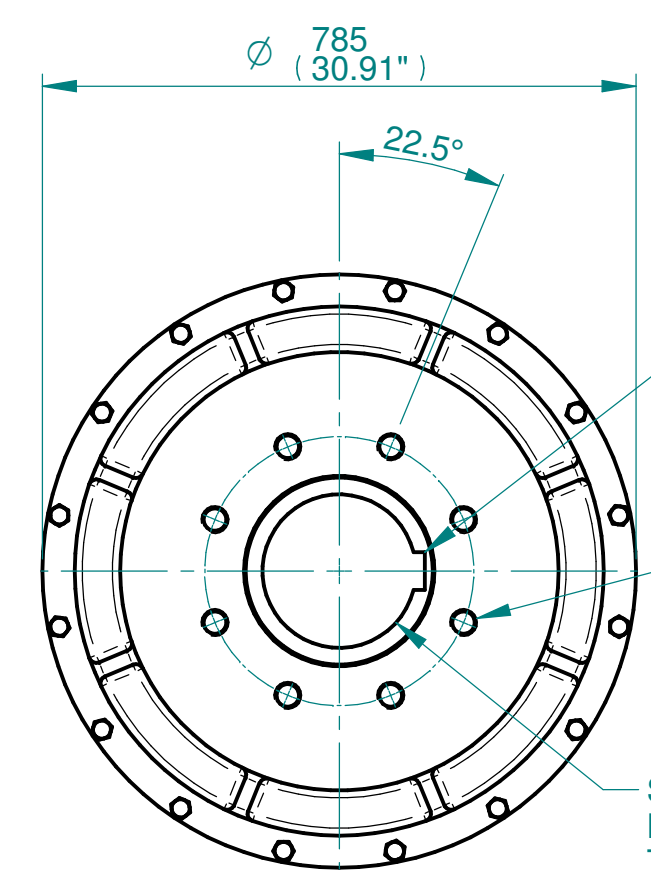
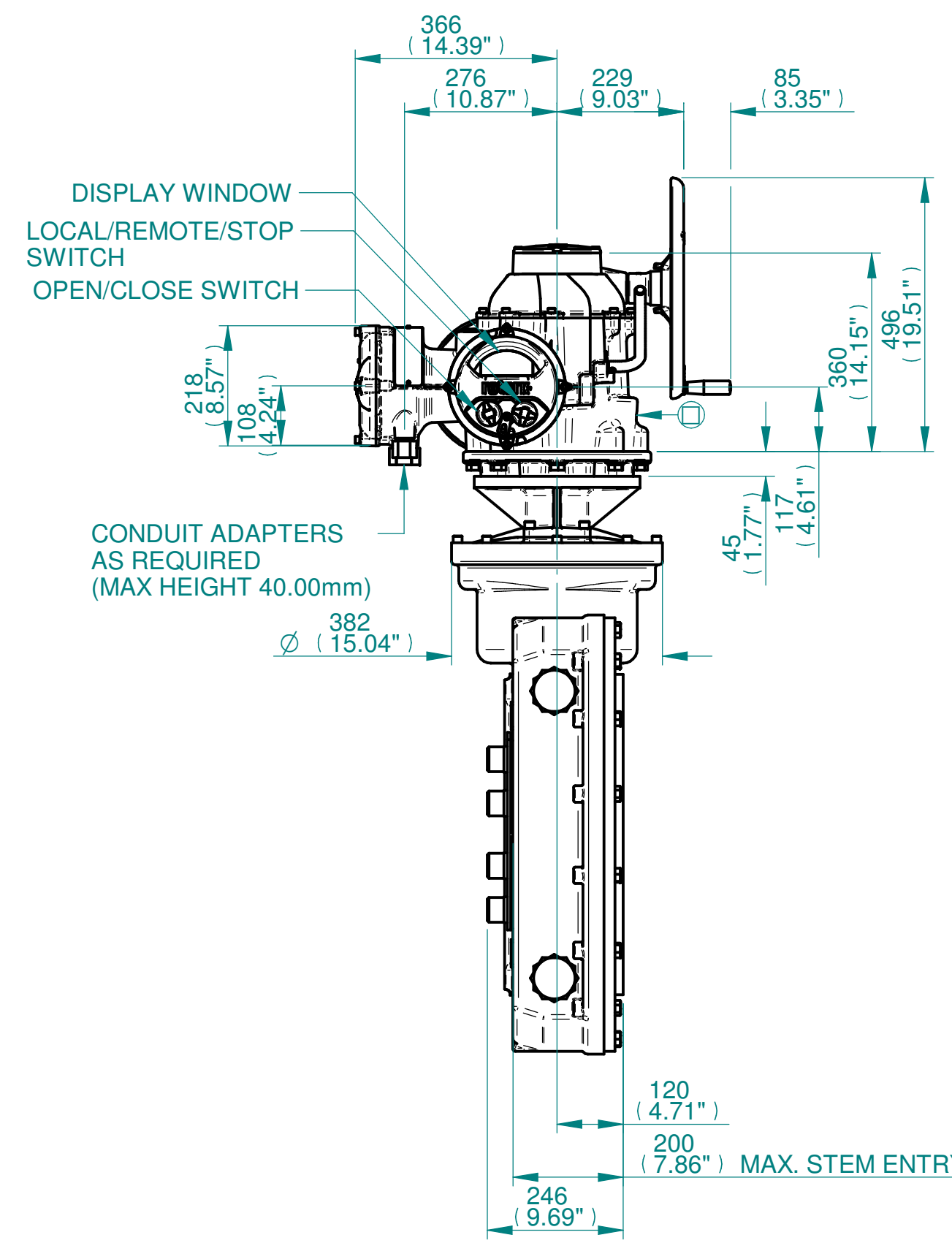
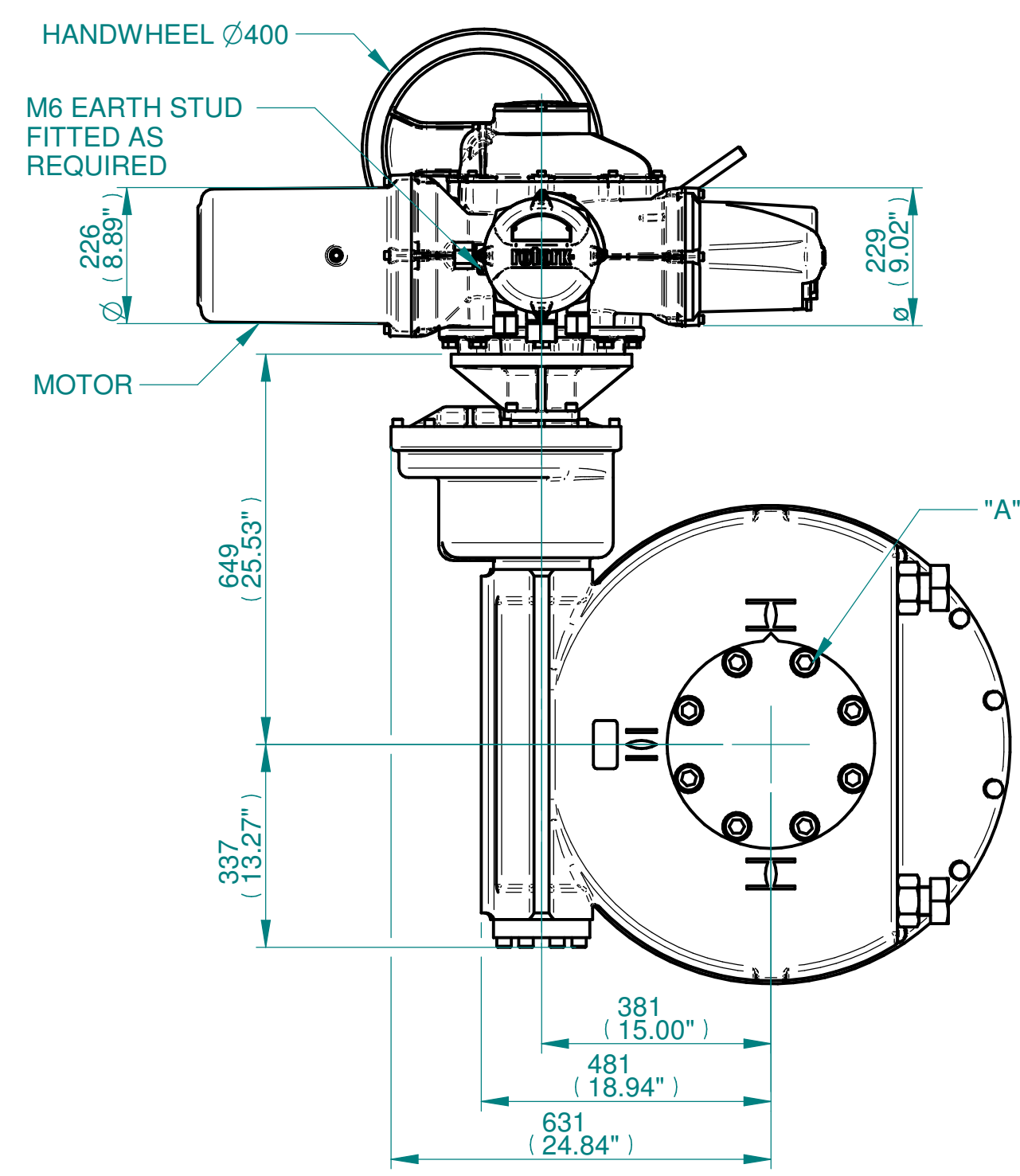

N.B. KEYWAY POS. CAN BE MOVED IN 45° STEPS BY REMOVING 8 SCREWS MARKED "A" AND ROTATING OUTPUT SLEEVE  
 SEE GEARBOX OUTPUT FLANGE OPTIONS TABLE  
 SEE MAXIMUM BORE & KEY TABLE

3D Models are available in various formats under the same drawing number

**rotork**  
 www.rotork.com  
 Rotork Controls Limited  
 Bath, BA1 3JQ, England.  
 Telephone 01225-733200

Actuator Size: IQ91 IW115 & 116IR35		Gearbox output flange options								Maximum Bore & Key			
Title	IQ91, SIDE HANDWHEEL, IW115IR35 / IW116IR35, F/FA35,40 & 48, Ratios 360 - 1093:1 Installation Details	Designation	F35	F40	F48	-	FA35	FA40	FA48	-	Key form	Ø Bore	Key size
Drawn	TED	No. Holes	8	8	12 NOT SHOWN	-	8	8	12 NOT SHOWN	-	Rectangle (BS4235)	270	63 X 32
Checked	NJC	Hole size	M30	M36	M36	-	1" UNC	1-1/4" UNC	1-1/4" UNC	-	Rectangle (ANSI B17.1)	7-5/8"	2 X 1-1/2"
Date	18-AUG-14	PCD	356	406	483	-	14"	16"	19"	-	Square (ANSI B17.1)	7-3/8"	1-3/4" SQ
Ref	SALES	Project Ref	QUOTATION										

Issue	Description
3	OUTPUT FLANGE CHANGE
Scale: 1:10	
THIRD ANGLE PROJECTION	
A2	Drawing Number Issue No Sheet No
115-91-SHWIW115IR35STD	3 1 of 1

1 2 3 4 5 6 7 8 9 10 11 12