

ISOMETRIC VIEW
(SCALE 1:12)

NOTES:
 :DIMENSIONS WITH "*" INDICATE COVER REMOVAL ALLOWANCE
 :ELECTRONICS COVER OPTION "****" WILL VARY DEPENDING ON CONFIGURATION
 :NETT WEIGHT = F25:215kg/474lbs, F30:221kg/488lbs
 : = OIL FILLER/DRAIN PLUG
 :THE INTERFACE PROVIDED FOR MOUNTING THE ACTUATOR OR SECOND STAGE GEARBOX ONTO THE VALVE SHOULD CONFORM TO GOOD ENGINEERING PRACTICES, ENSURING ADEQUATELY TOLERANCED LIMITS FOR PARALLELISM, PERPENDICULARITY AND CONCENTRICITY.
 :ROTORK CANNOT BE HELD LIABLE FOR DAMAGE TO OUR EQUIPMENT CAUSED BY EXCESSIVE LOADING FROM COVER TUBES. (SEE ALSO PUB000-124)

CONDUIT ENTRIES

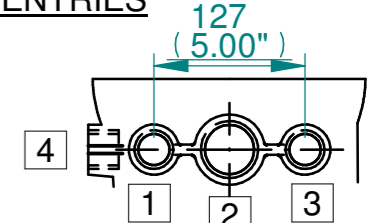

	Hole 1	Hole 2	Hole 3	Hole 4
Size	As Required	As Required	As Required	As Required
Plugged	As Required	As Required	As Required	As Required
Gland	As Required	As Required	As Required	As Required

BATTERY HOUSING
 TERMINAL HOUSING
 IDENTIFICATION PLATE
 ELECTRONICS COVER (LONG) **
 ELECTRONICS COVER (SHORT) **

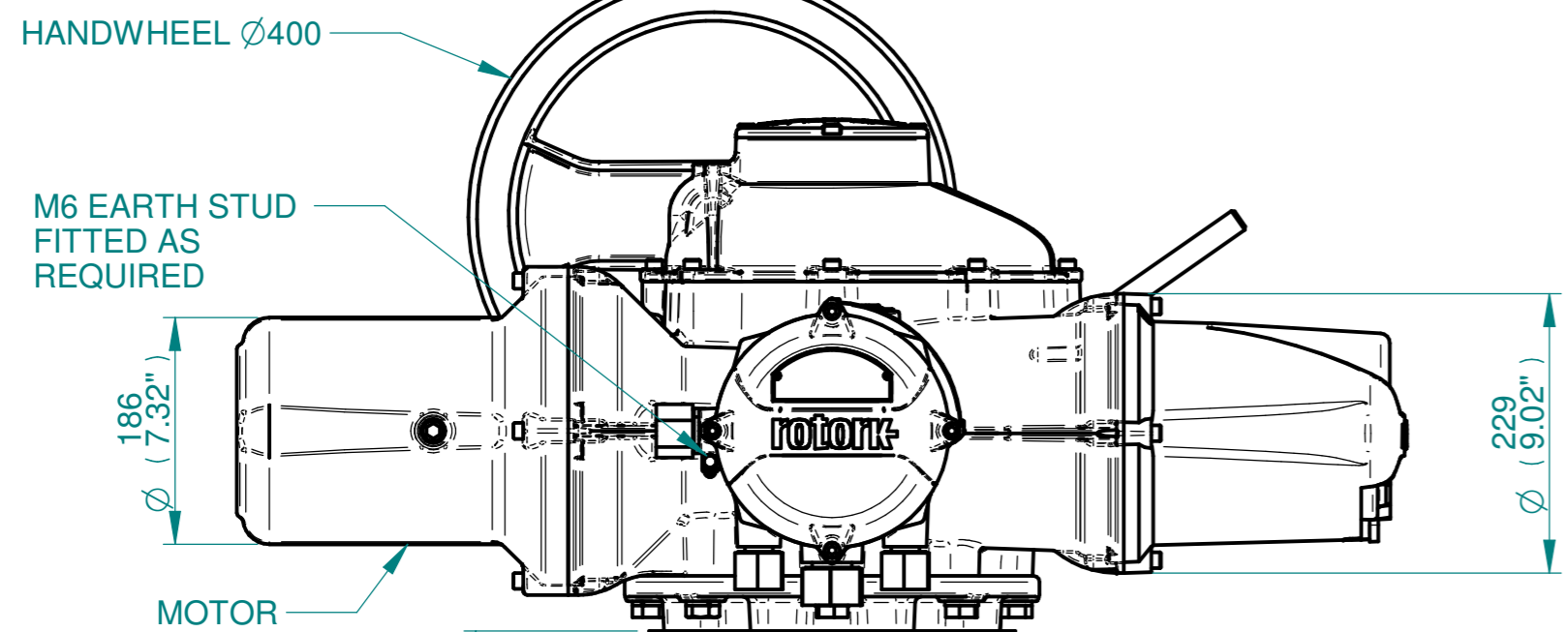

M6 EARTH STUD
 FITTED AS
 REQUIRED

MOTOR

TO SUIT
 VALVE TRAVEL

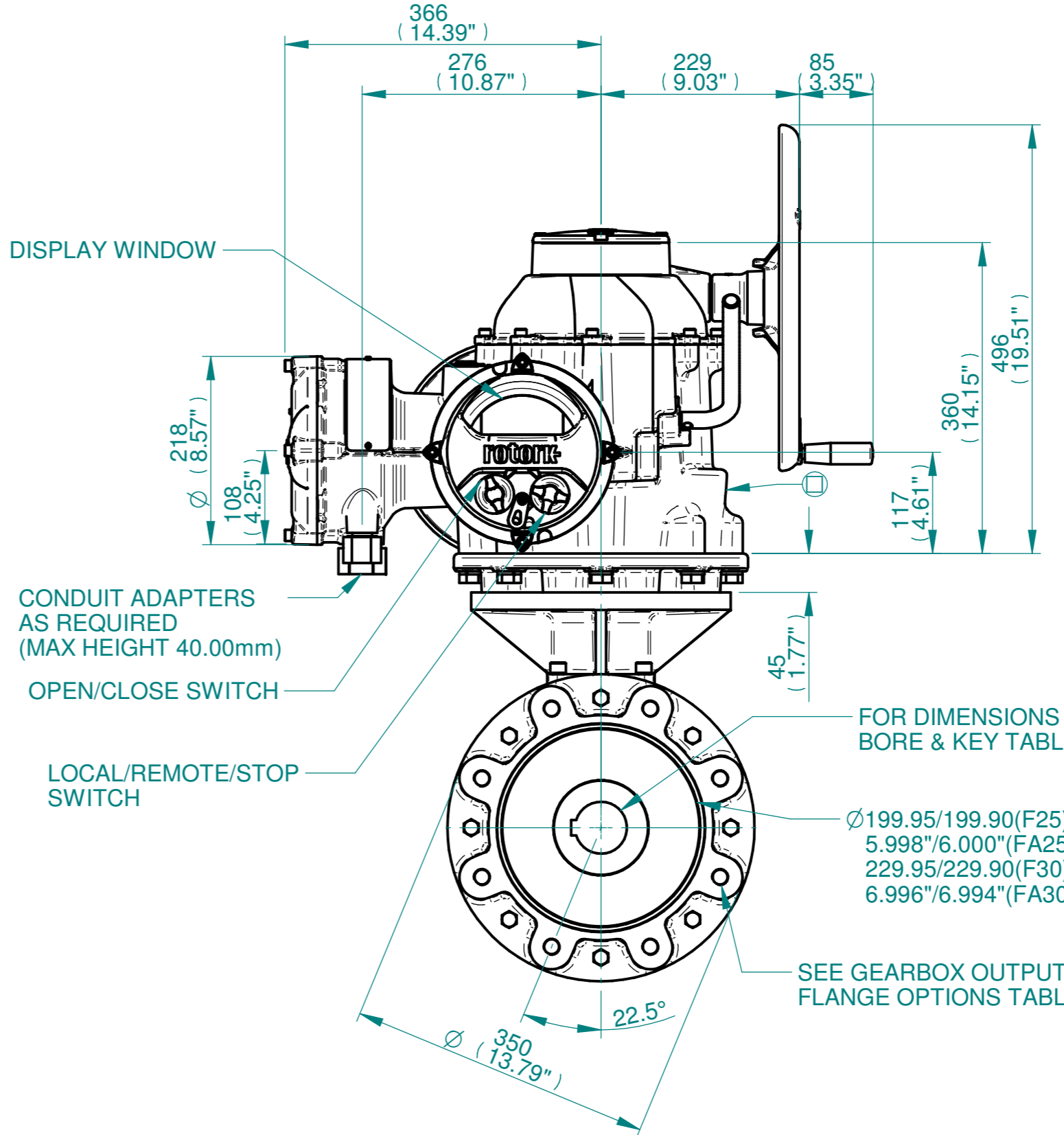

DISPLAY WINDOW

CONDUIT ADAPTERS
 AS REQUIRED
 (MAX HEIGHT 40.00mm)

OPEN/CLOSE SWITCH

LOCAL/REMOTE/STOP
 SWITCH

FOR DIMENSIONS SEE MAXIMUM
 BORE & KEY TABLE

Ø199.95/199.90(F25)
 5.998"/6.000"(FA25)
 229.95/229.90(F30)
 6.996"/6.994"(FA30)

SEE GEARBOX OUTPUT
 FLANGE OPTIONS TABLE

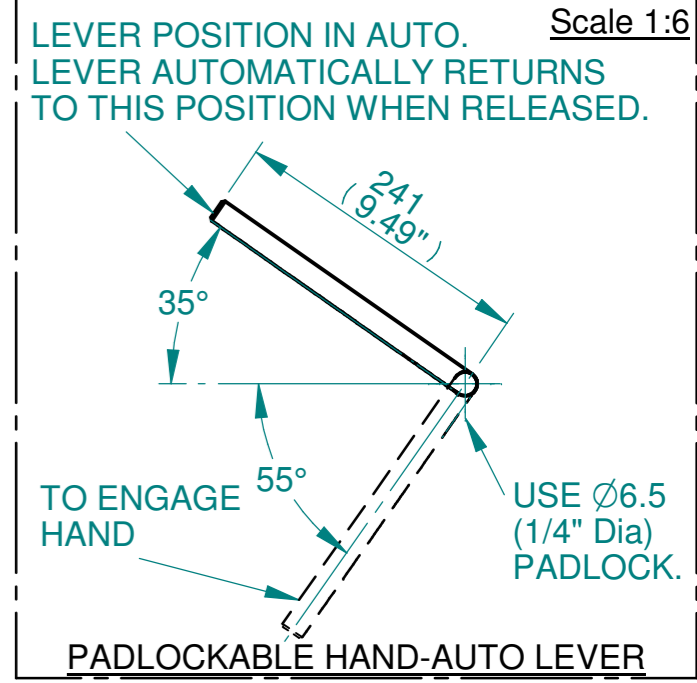

LEVER POSITION IN AUTO.
 LEVER AUTOMATICALLY RETURNS
 TO THIS POSITION WHEN RELEASED.

PADLOCKABLE HAND-AUTO LEVER

Scale 1:6



Rotork Controls Limited
 Bath, BA1 3JQ, England.
 Telephone 01225-733200

Actuator Size: IQ40, IB9, F25/F30/FA25/FA30		Gearbox output flange options								Maximum Bore & Key			
Title	IQ40, SIDE HANDWHEEL, IB9, F25/F30/FA25/FA30, Ratios 3:1, 4:1 & 6:1 Installation Details	Designation	F25	F30	-	-	FA25	FA30	-	-	Key form	Ø Bore	Key size
Drawn	TCE	No. Holes	8	8	-	-	8	8	-	-	Rectangle (BS4235)	76	22 X 14
Checked	NJC	Hole size	M16	M20	-	-	5/8" UNC	3/4" UNC	-	-	Rectangle (ANSI B17.1)	3"	3/4 X 1/2"
Date	19-AUG-14	PCD	254	298	-	-	10"	11.75"	-	-	Square (ANSI B17.1)	2-3/4"	3/4"
Ref	SALES	Project Ref	QUOTATION										

Issue	Description
2	4 ENTRY CHANGE

Scale: 1:5

THIRD ANGLE PROJECTION

Drawing Number	Issue No	Sheet No
I14SHWIB9STD	2	1 of 1