

NOTES:
 :DIMENSIONS WITH "*" INDICATE COVER REMOVAL ALLOWANCE
 :ELECTRONICS COVER OPTION "****" WILL VARY DEPENDING ON CONFIGURATION
 :NETT WEIGHT = F35:345kg/761lbs, F40:360kg/794lbs
 : = OIL FILLER/DRAIN PLUG
 :THE INTERFACE PROVIDED FOR MOUNTING THE ACTUATOR OR SECOND STAGE GEARBOX ONTO THE VALVE SHOULD CONFORM TO GOOD ENGINEERING PRACTICES, ENSURING ADEQUATELY TOLERANCED LIMITS FOR PARALLELISM, PERPENDICULARITY AND CONCENTRICITY.
 :ROTORK CANNOT BE HELD LIABLE FOR DAMAGE TO OUR EQUIPMENT CAUSED BY EXCESSIVE LOADING FROM COVER TUBES. (SEE ALSO PUB000-124)

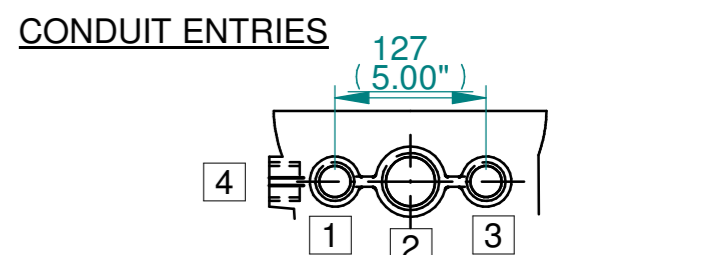

	Hole 1	Hole 2	Hole 3	Hole 4
Size	As Required	As Required	As Required	As Required
Plugged	As Required	As Required	As Required	As Required
Gland	As Required	As Required	As Required	As Required

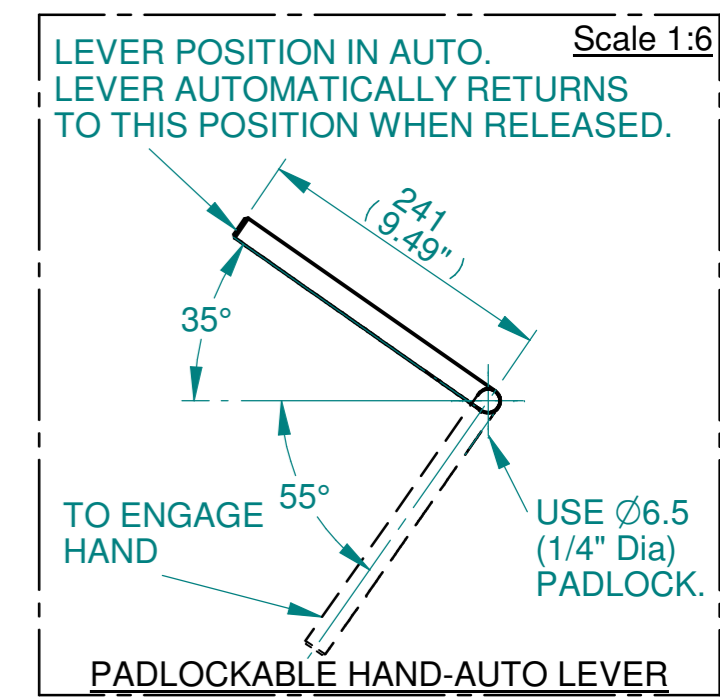

rotork
 www.rotork.com
 Rotork Controls Limited
 Bath, BA1 3JQ, England.
 Telephone 01225-733200

Actuator Size: IQ40, IB13, F35/F40/FA35/FA40		Gearbox output flange options								Maximum Bore & Key			
Title	IQ40, SIDE HANDWHEEL, IB13, F35/F40/FA35/FA40 Ratios 6:1 & 8:1 Installation Details	Designation	F35	F40	-	-	FA35	FA40	-	-	Key form	Ø Bore	Key size
Drawn	TCE	No. Holes	8	8	-	-	8	8	-	-	Rectangle (BS4235)	121	32 X 18
Checked	NJC	Hole size	M30	M36	-	-	1" UNC	1-1/4" UNC	-	-	Rectangle (ANSI B17.1)	4-5/8"	1-1/4 X 7/8"
Date	19-AUG-14	PCD	356	406	-	-	14"	16"	-	-	Square (ANSI B17.1)	4-1/2"	1-1/4"
Project Ref	SALES QUOTATION												

Issue	Description
2	4 ENTRY CHANGE

Scale: 1:5 THIRD ANGLE PROJECTION

Drawing Number	Issue No	Sheet No
I14SHWIB13STD	2	1 of 1