

H
G
F
E
D
C
B
A

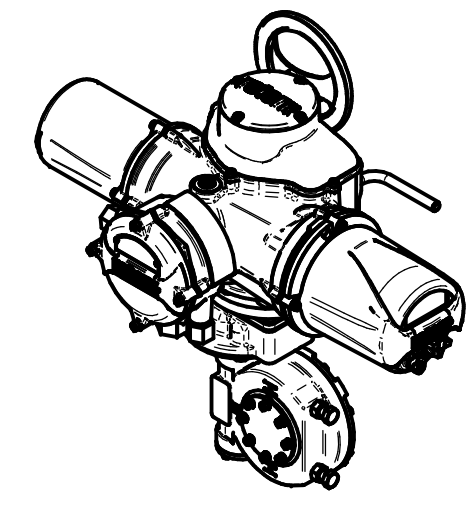
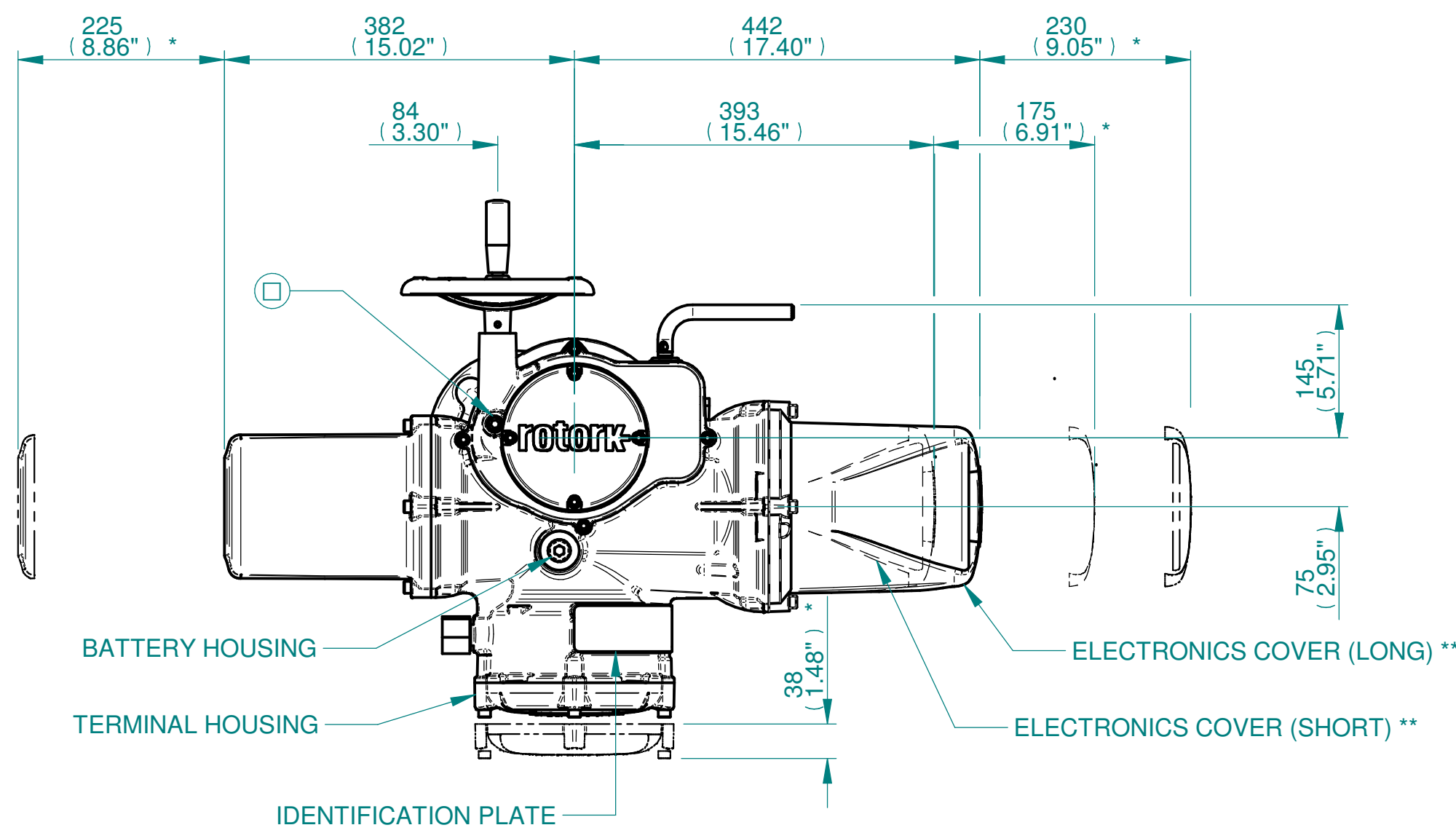

ISOMETRIC VIEW (SCALE 1:12)

NOTES:
 :DIMENSIONS WITH "*" INDICATE COVER REMOVAL ALLOWANCE
 :ELECTRONICS COVER OPTION "****" WILL VARY DEPENDING ON CONFIGURATION
 :NETT WEIGHT = 105kg/231lbs
 : = OIL FILLER/DRAIN PLUG
 :THE INTERFACE PROVIDED FOR MOUNTING THE ACTUATOR OR SECOND STAGE GEARBOX ONTO THE VALVE SHOULD CONFORM TO GOOD ENGINEERING PRACTICES, ENSURING ADEQUATELY TOLERANCED LIMITS FOR PARALLELISM, PERPENDICULARITY AND CONCENTRICITY.
 :ROTORK CANNOT BE HELD LIABLE FOR DAMAGE TO OUR EQUIPMENT CAUSED BY EXCESSIVE LOADING FROM COVER TUBES. (SEE ALSO PUB000-124)

CONDUIT ENTRIES

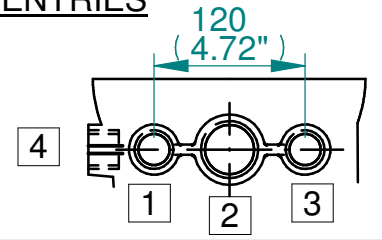

	Hole 1	Hole 2	Hole 3	Hole 4
Size	As Required	As Required	As Required	As Required
Plugged	As Required	As Required	As Required	As Required
Gland	As Required	As Required	As Required	As Required

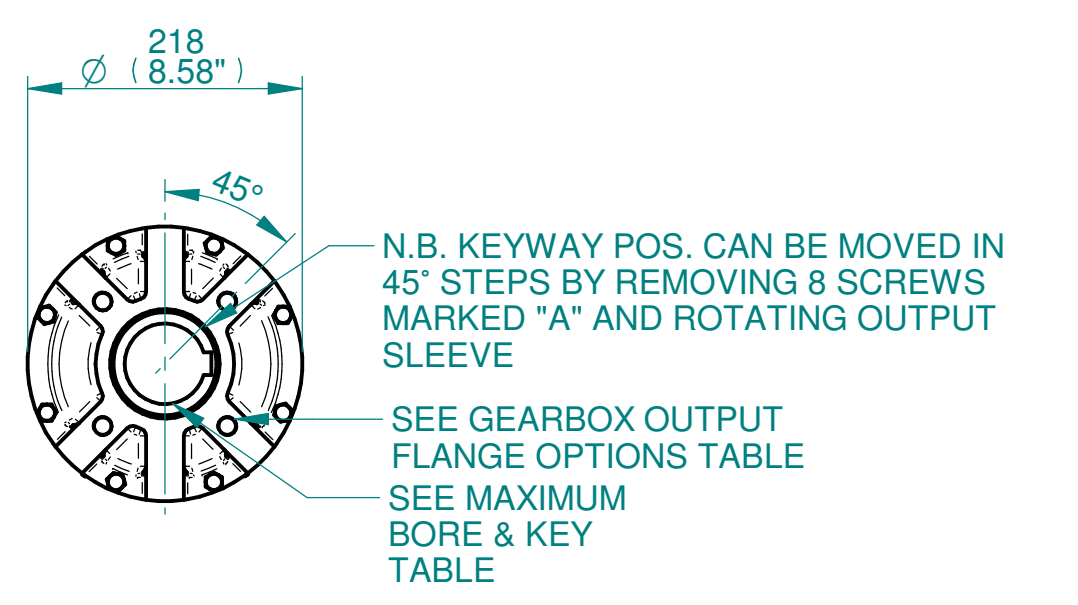
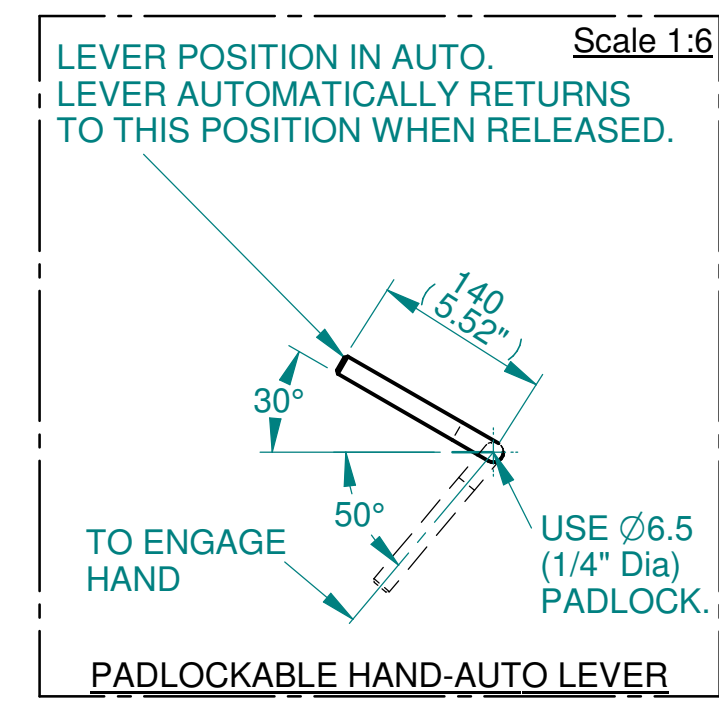
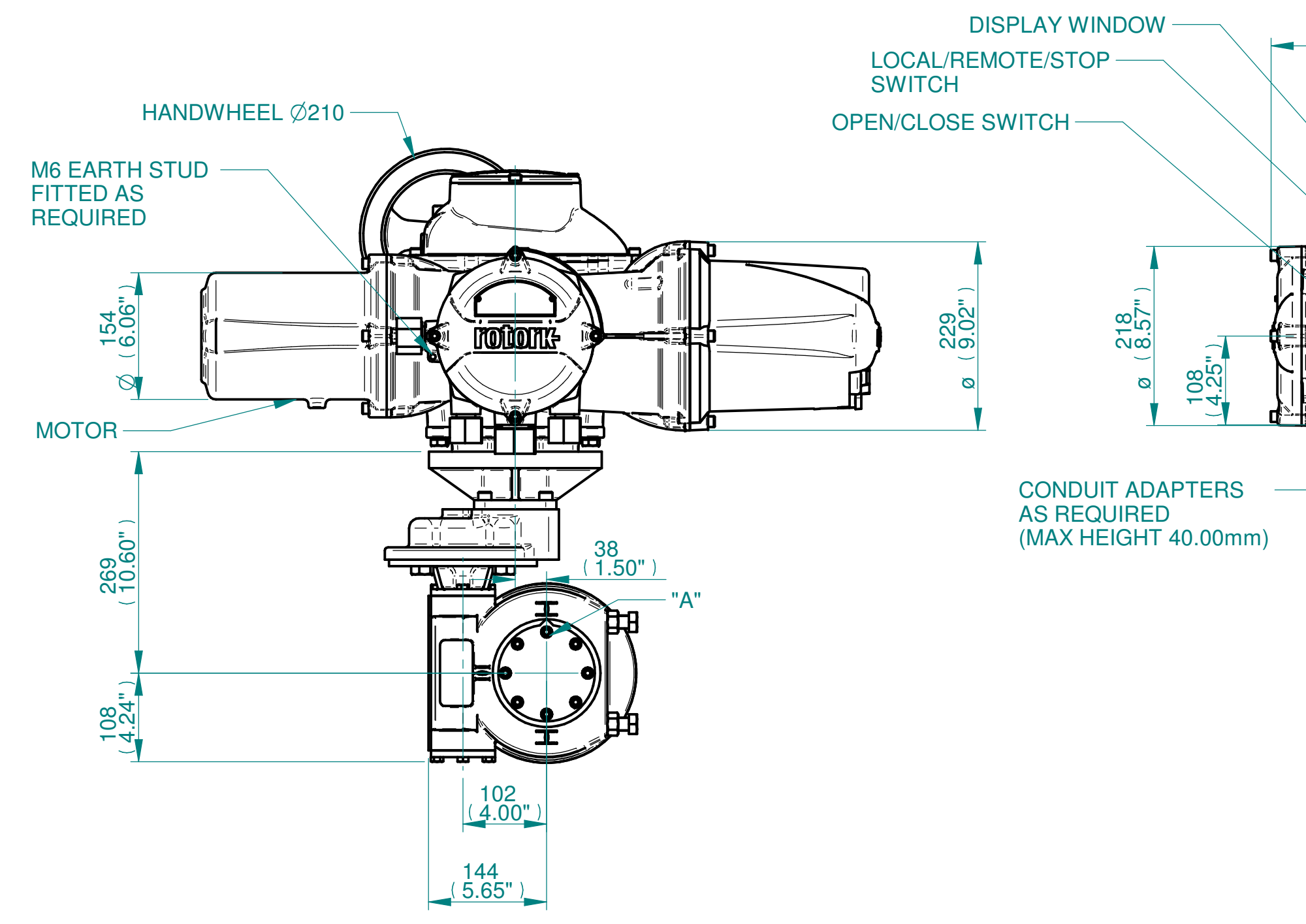

3D Models are available in various formats under the same drawing number



www.rotork.com
 Rotork Controls Limited
 Bath, BA1 3JQ, England.
 Telephone 01225-733200

Actuator Size: IQ35 IW4RL/MOW4RL		Gearbox output flange options								Maximum Bore & Key			
Title	IQ35, SIDE HANDWHEEL, IW4RL/MOW4RL, F12/F14/FA12/FA14, Ratios 80:1 - 160:1, 210:1 & 280:1 Installation Details	Designation	F12	F14	-	-	FA12	FA14	-	-	Key form	Ø Bore	Key size
Drawn	TED	No. Holes	4	4	-	-	4	4	-	-	Rectangle (BS4235)	64	18 X 11
Checked	NJC	Hole size	M12	M16	-	-	1/2" UNC	5/8" UNC	-	-	Rectangle (ANSI B17.1)	2-1/2"	5/8 X 7/16"
Date	18-AUG-14	PCD	125	140	-	-	4.95"	5.5"	-	-	Square (ANSI B17.1)	2-1/4"	1/2" SQ
Ref	SALES	Project Ref	QUOTATION										

Issue	Description
2	4 ENTRY CHANGE

Scale: 1:6 THIRD ANGLE PROJECTION

Drawing Number	Issue No	Sheet No
I13SHWIW4RLSTD	2	1 of 1

1 2 3 4 5 6 7 8 9 10 11 12