

H
G
F
E
D
C
B
A

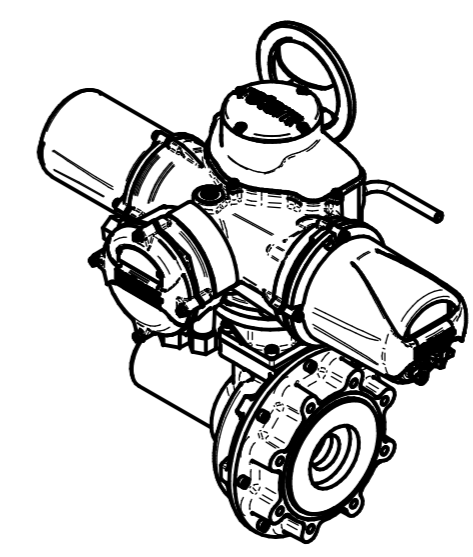
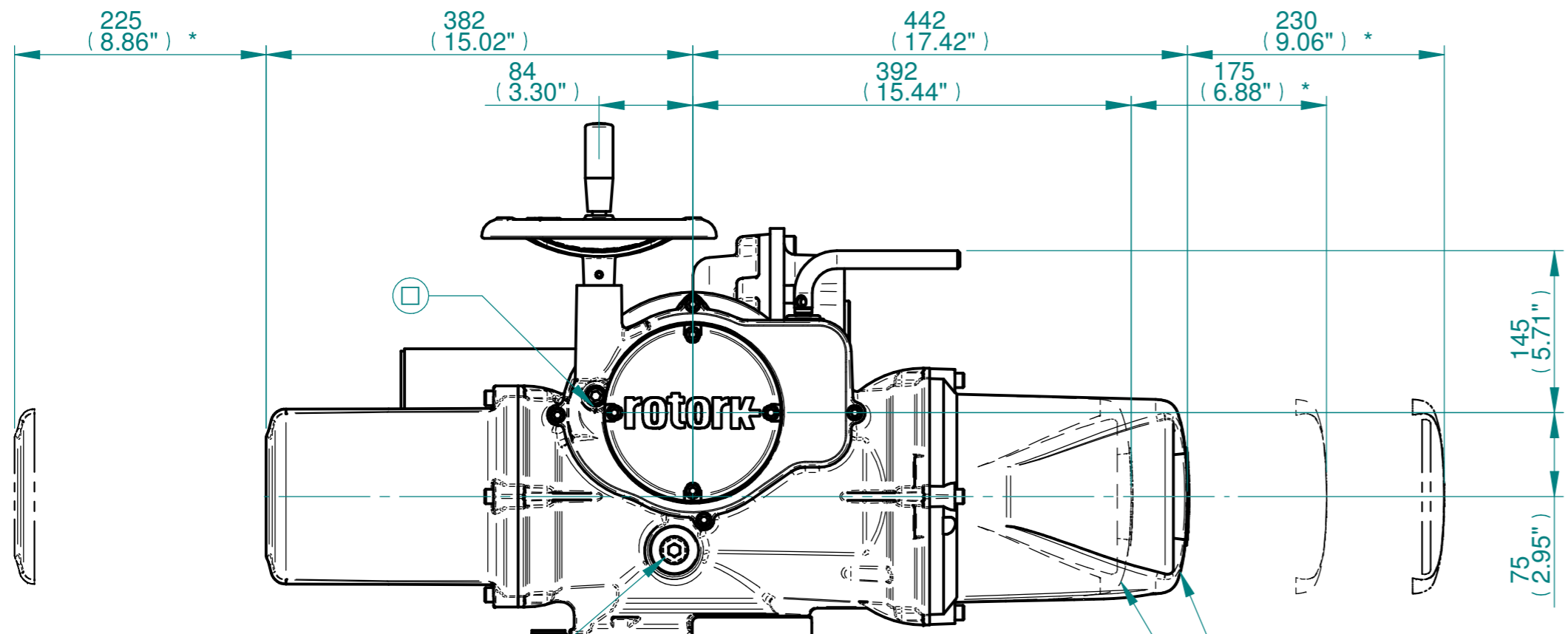

ISOMETRIC VIEW (SCALE 1:12)

NOTES:
 :DIMENSIONS WITH "*" INDICATE COVER REMOVAL ALLOWANCE
 :ELECTRONICS COVER OPTION "****" WILL VARY DEPENDING ON CONFIGURATION
 :NETT WEIGHT = F25:145kg/319lbs, F30:151kg/333lbs
 : = OIL FILLER/DRAIN PLUG
 :THE INTERFACE PROVIDED FOR MOUNTING THE ACTUATOR OR SECOND STAGE GEARBOX ONTO THE VALVE SHOULD CONFORM TO GOOD ENGINEERING PRACTICES, ENSURING ADEQUATELY TOLERANCED LIMITS FOR PARALLELISM, PERPENDICULARITY AND CONCENTRICITY.
 :ROTORK CANNOT BE HELD LIABLE FOR DAMAGE TO OUR EQUIPMENT CAUSED BY EXCESSIVE LOADING FROM COVER TUBES. (SEE ALSO PUB000-124)

CONDUIT ENTRIES

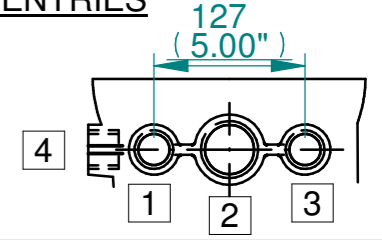

	Hole 1	Hole 2	Hole 3	Hole 4
Size	As Required	As Required	As Required	As Required
Plugged	As Required	As Required	As Required	As Required
Gland	As Required	As Required	As Required	As Required

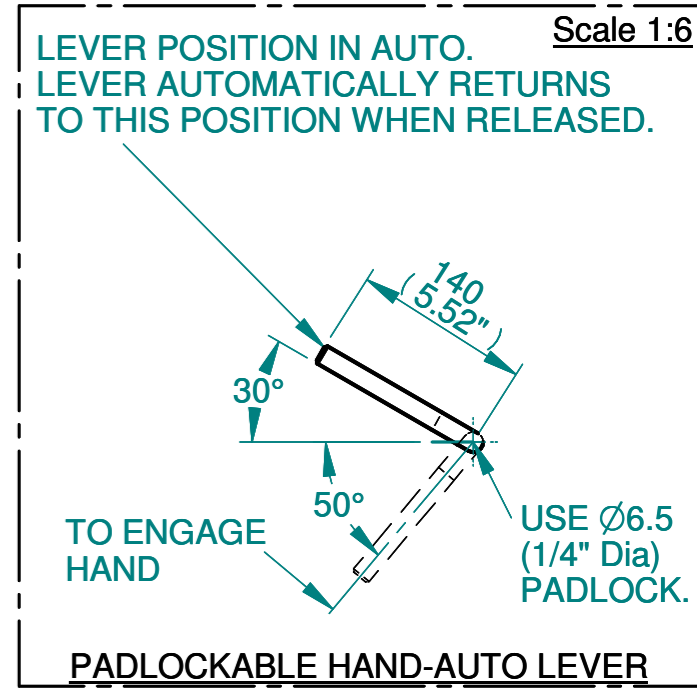
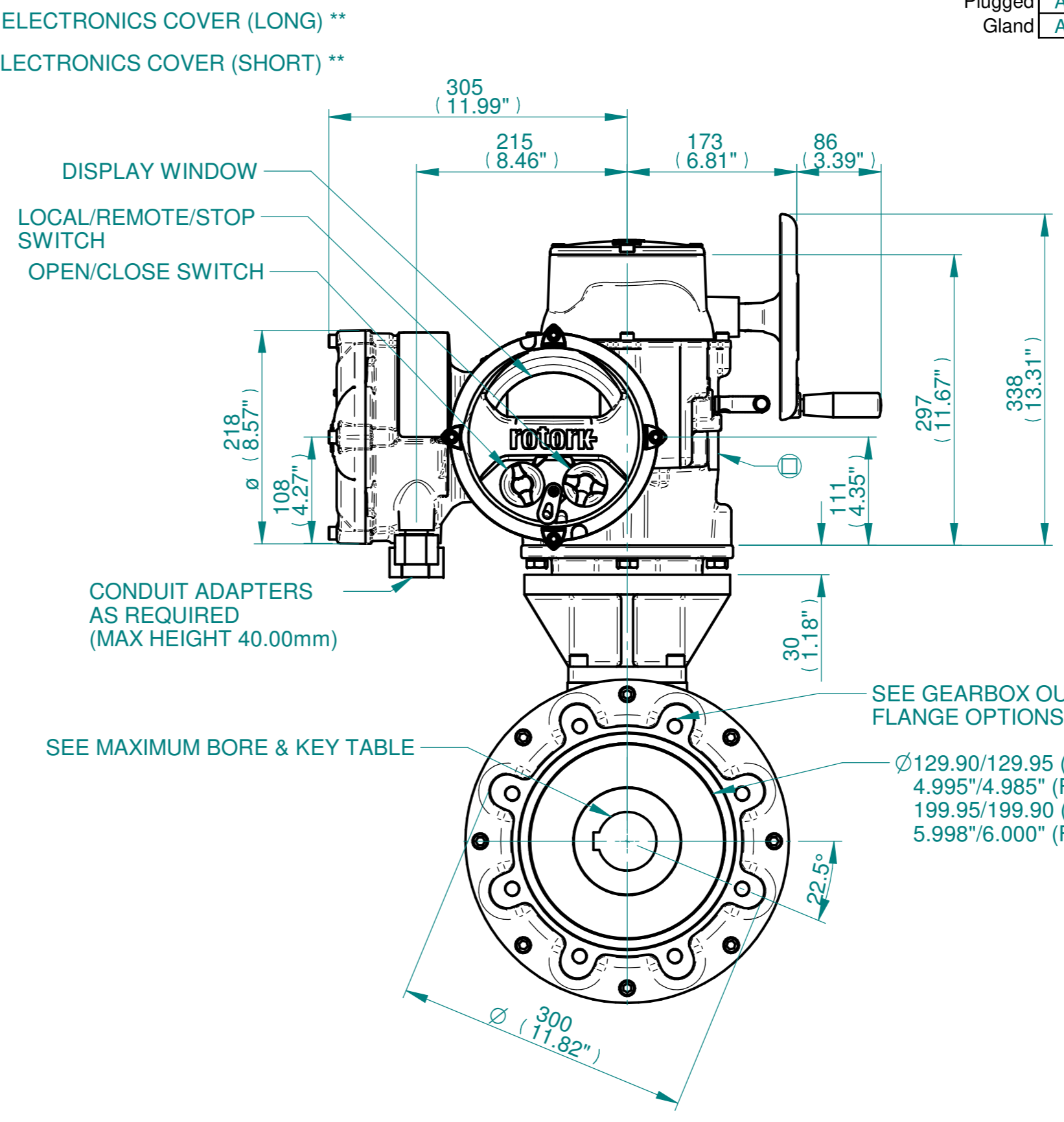
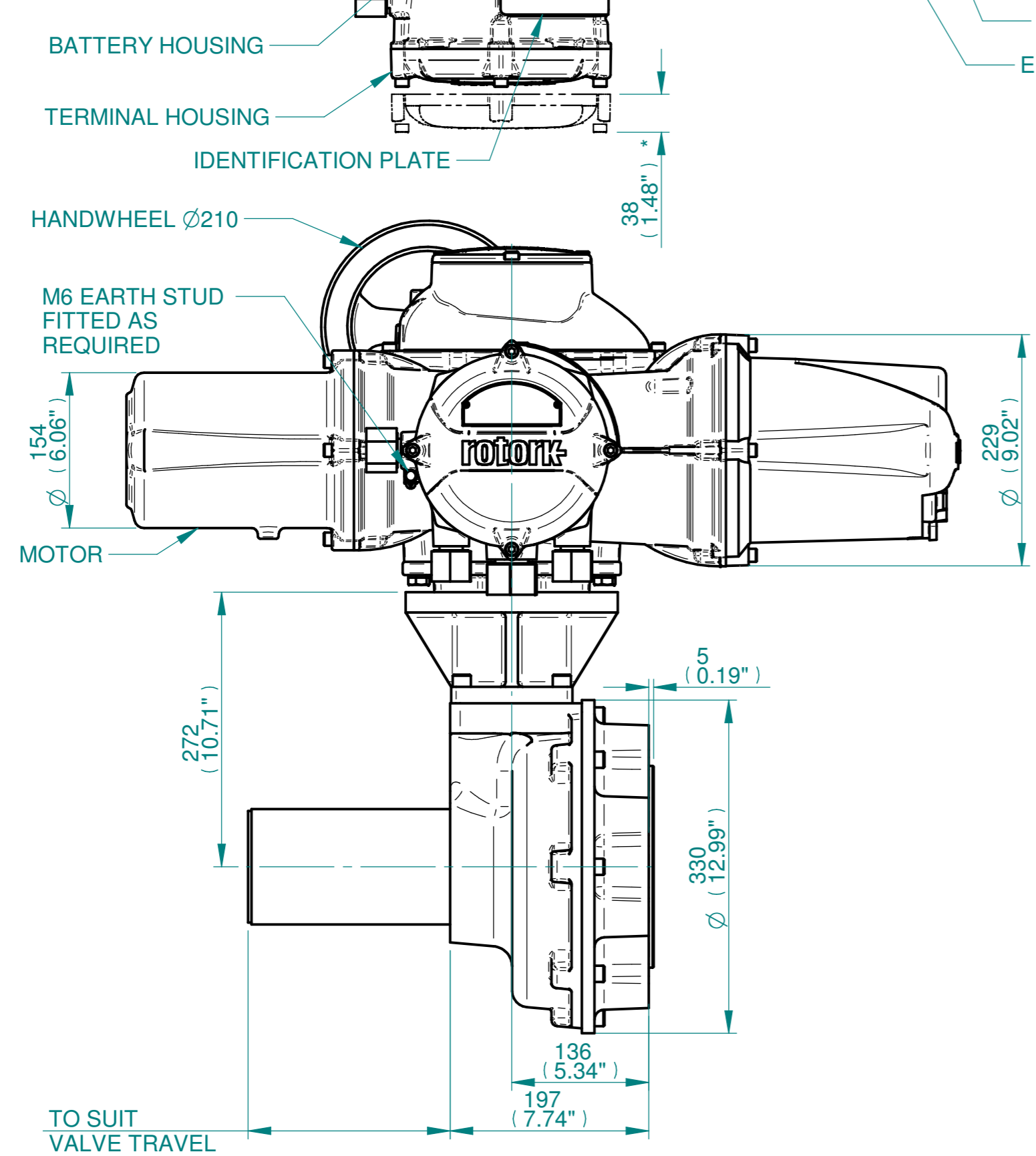

Actuator Size: IQ35, IB9, F25/F30/FA25/FA30		Gearbox output flange options								Maximum Bore & Key			
rotork www.rotork.com Rotork Controls Limited Bath, BA1 3JQ, England. Telephone 01225-733200	Title IQ35, SIDE HANDWHEEL, IB9, F25/F30/FA25/FA30, Ratios 3:1,4:1 & 6:1 Installation Details	Designation	F25	F30	-	-	FA25	FA30	-	-	Key form	Ø Bore	Key size
	Drawn JLF Checked NJC Date 13-MAR-15	No. Holes	8	8	-	-	8	8	-	-	Rectangle (BS4235)	76	22 X 14
	Ref SALES Project Ref QUOTATION	Hole size	M16	M20	-	-	5/8" UNC	3/4" UNC	-	-	Rectangle (ANSI B17.1)	3"	3/4 X 1/2"
		PCD	254	298	-	-	10"	11.75"	-	-	Square (ANSI B17.1)	2-3/4"	3/4"

Issue	Description
2	4 ENTRY CHANGE

Scale: 1:5 THIRD ANGLE PROJECTION

Drawing Number	Issue No	Sheet No
I13SHWIB9STD	2	1 of 1

1 2 3 4 5 6 7 8 9 10 11 12