

NOTES:
 :DIMENSIONS WITH "*" INDICATE COVER REMOVAL ALLOWANCE
 :ELECTRONICS COVER OPTION "****" WILL VARY DEPENDING ON CONFIGURATION
 :NETT WEIGHT = F14:103kg/227lbs,F16:107kg/236lbs
 : = OIL FILLER/DRAIN PLUG
 :THE INTERFACE PROVIDED FOR MOUNTING THE ACTUATOR OR SECOND STAGE GEARBOX ONTO THE VALVE SHOULD CONFORM TO GOOD ENGINEERING PRACTICES, ENSURING ADEQUATELY TOLERANCED LIMITS FOR PARALLELISM, PERPENDICULARITY AND CONCENTRICITY.
 :ROTORK CANNOT BE HELD LIABLE FOR DAMAGE TO OUR EQUIPMENT CAUSED BY EXCESSIVE LOADING FROM COVER TUBES. (SEE ALSO PUB000-124)

CONDUIT ENTRIES

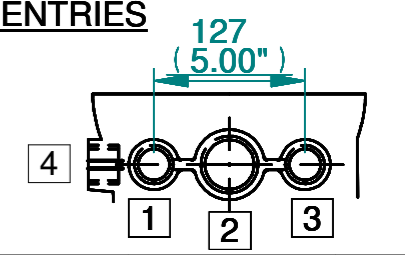

	Hole 1	Hole 2	Hole 3	Hole 4
Size	As Required	As Required	As Required	As Required
Plugged	As Required	As Required	As Required	As Required
Gland	As Required	As Required	As Required	As Required

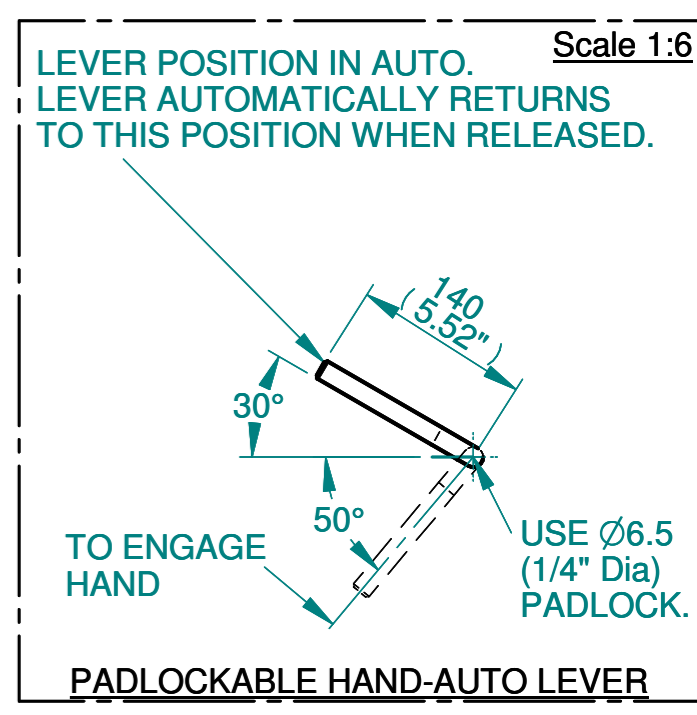
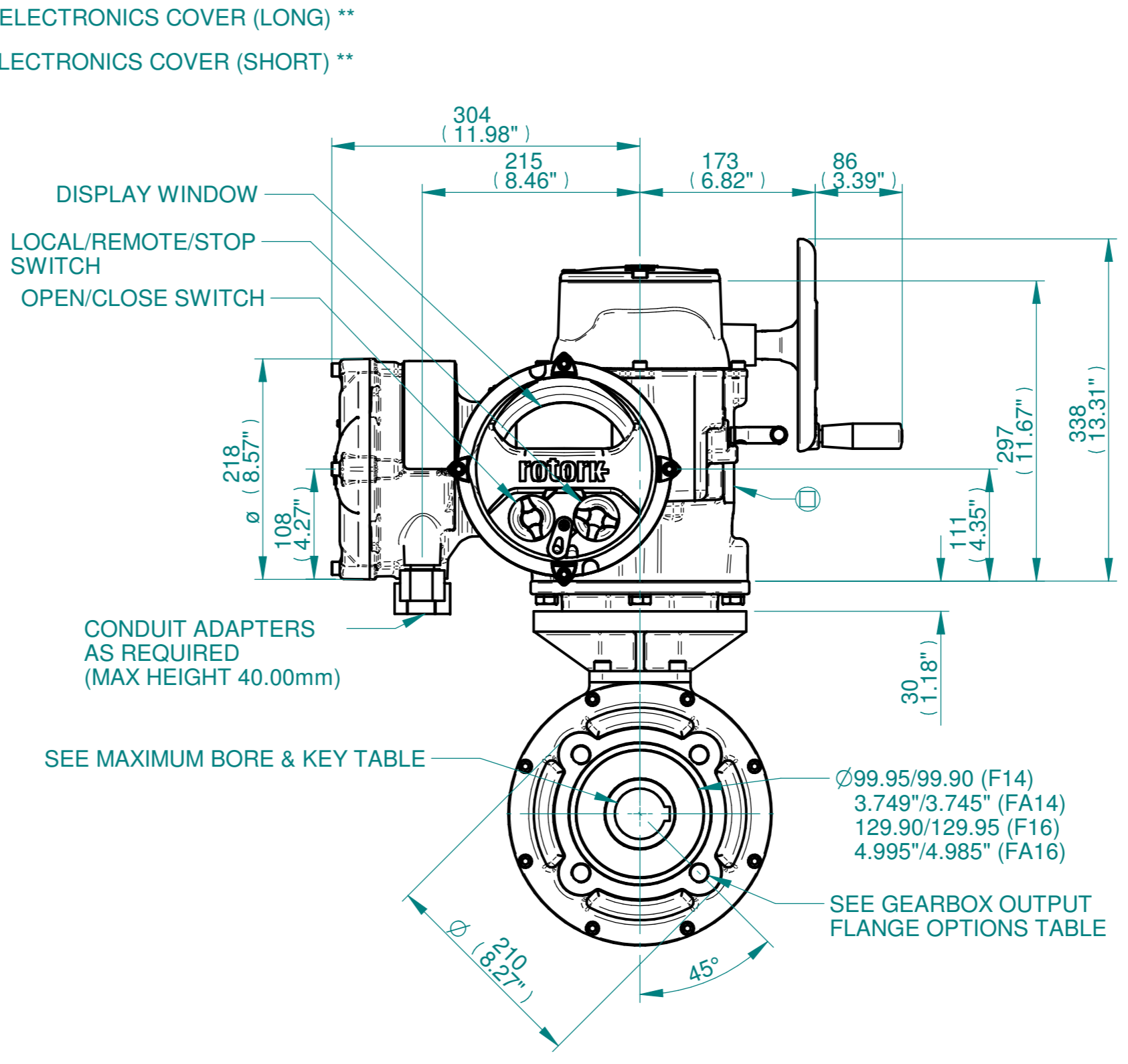
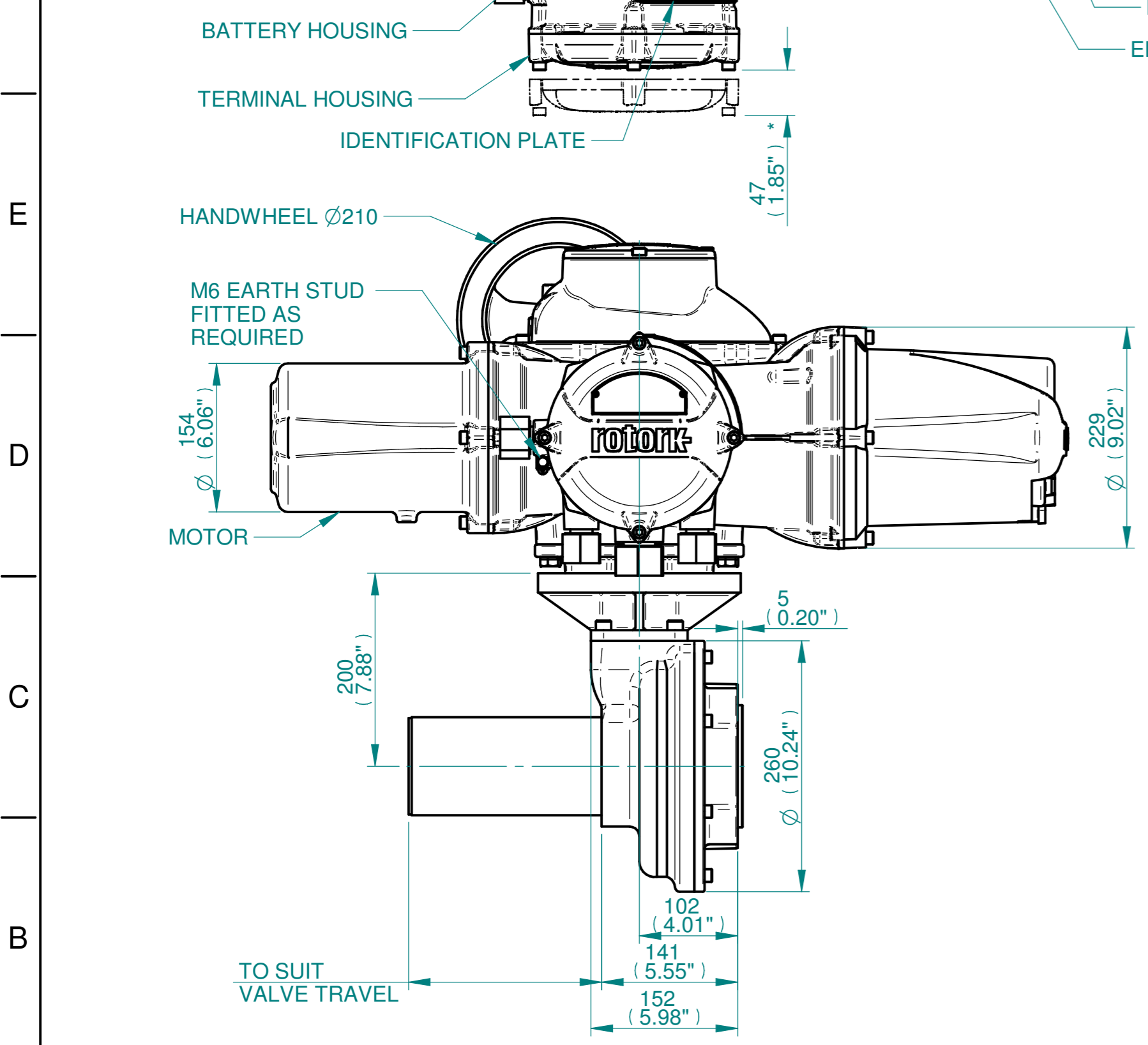

rotork
 www.rotork.com
 Rotork Controls Limited
 Bath, BA1 3JQ, England.
 Telephone 01225-733200

Actuator Size: IQ35, IB6, F14/F16/FA14/FA16		Gearbox output flange options								Maximum Bore & Key		
Title IQ35, SIDE HANDWHEEL, IB6 F14/F16/FA14/FA16 Ratios 3:1, 4:1 & 6:1 Installation Details Drawn JLF Checked NJC Date 13-MAR-15 Ref SALES Project Ref QUOTATION	Designation	F14	F16	-	-	FA14	FA16	-	-	Key form	Ø Bore	Key size
	No. Holes	4	4	-	-	4	4	-	-	Rectangle (BS4235)	52	16 X 10
	Hole size	M16	M20	-	-	5/8" UNC	3/4" UNC	-	-	Rectangle (ANSI B17.1)	2"	1/2 X 3/8"
	PCD	140	165	-	-	5.5"	6.5"	-	-	Square (ANSI B17.1)	1-7/8"	1/2"

Issue	Description
3	Gearbox ratios changed

Scale: 1:5 THIRD ANGLE PROJECTION

Drawing Number	Issue No	Sheet No
I13SHWIB6STD	3	1 of 1