

H
G
F
E
D
C
B
A

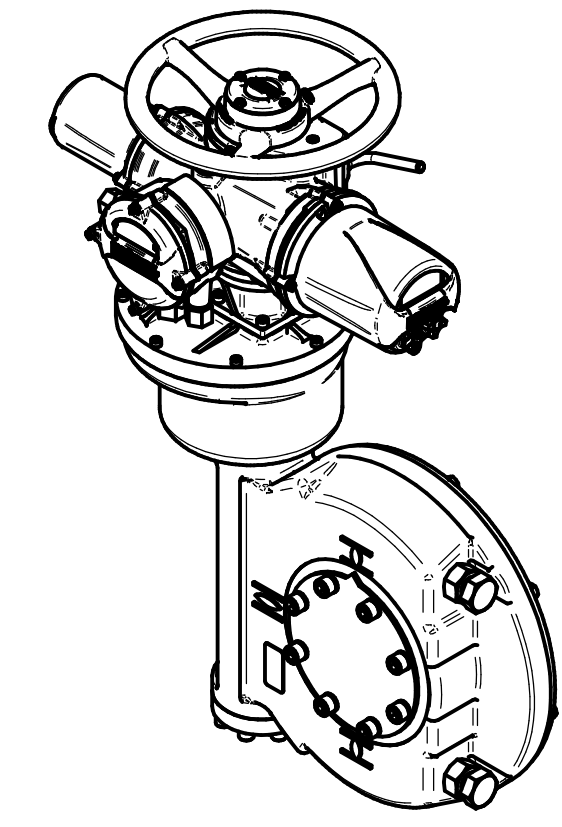

NOTES:
 :DIMENSIONS WITH "*" INDICATE COVER REMOVAL ALLOWANCE
 :ELECTRONICS COVER OPTION "*" WILL VARY DEPENDING ON CONFIGURATION
 :NETT WEIGHT = 369kg/813lbs
 : = OIL FILLER/DRAIN PLUG
 :THE INTERFACE PROVIDED FOR MOUNTING THE ACTUATOR OR SECOND STAGE GEARBOX ONTO THE VALVE SHOULD CONFORM TO GOOD ENGINEERING PRACTICES, ENSURING ADEQUATELY TOLERANCED LIMITS FOR PARALLELISM, PERPENDICULARITY AND CONCENTRICITY.
 :ROTORK CANNOT BE HELD LIABLE FOR DAMAGE TO OUR EQUIPMENT CAUSED BY EXCESSIVE LOADING FROM COVER TUBES. (SEE ALSO PUB000-124)

CONDUIT ENTRIES

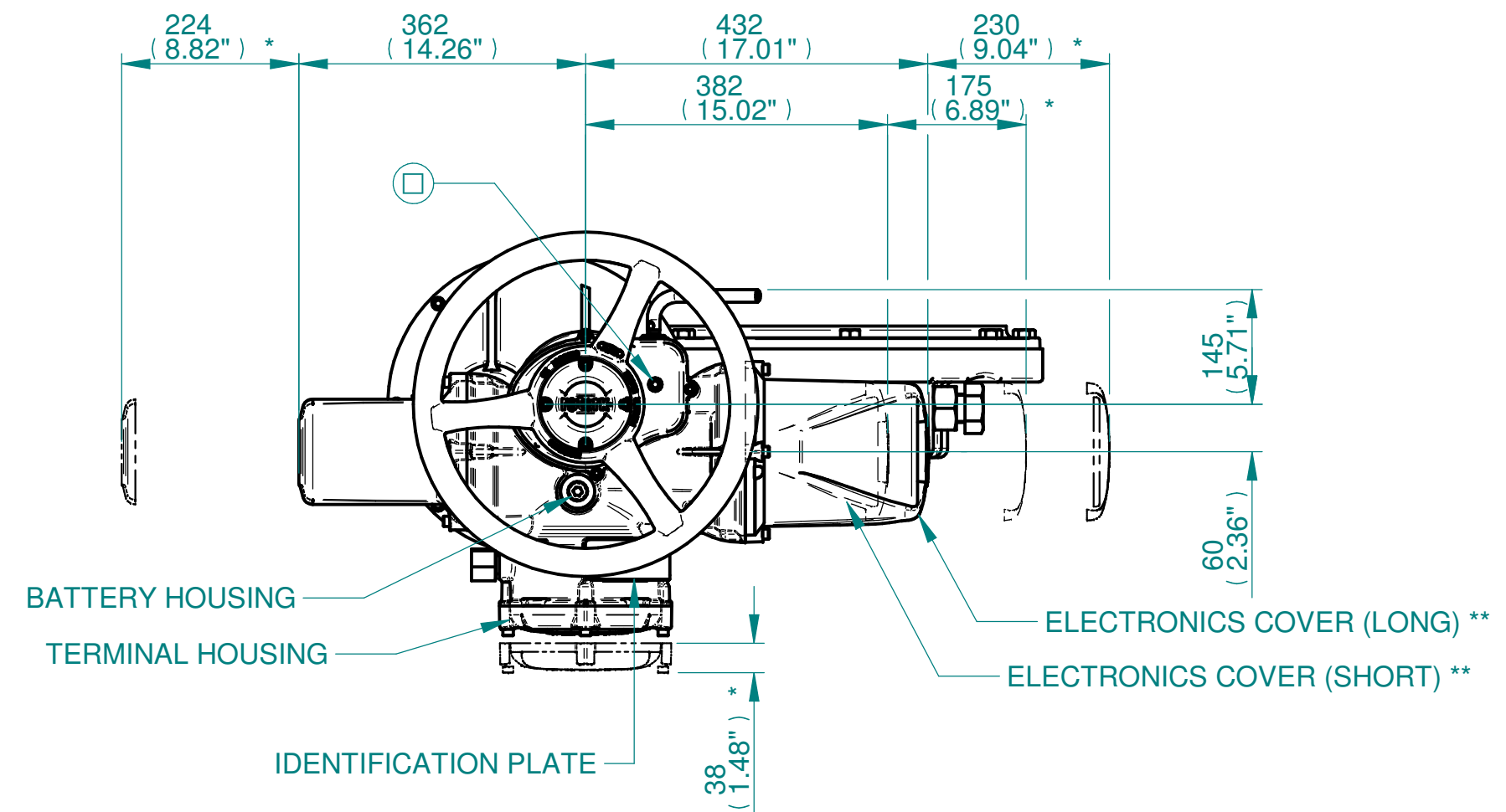
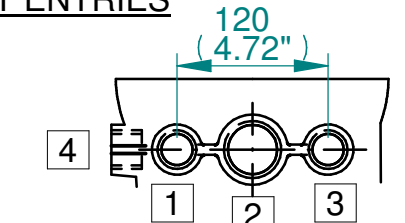

	Hole 1	Hole 2	Hole 3	Hole 4
Size	As Required	As Required	As Required	As Required
Plugged	As Required	As Required	As Required	As Required
Gland	As Required	As Required	As Required	As Required

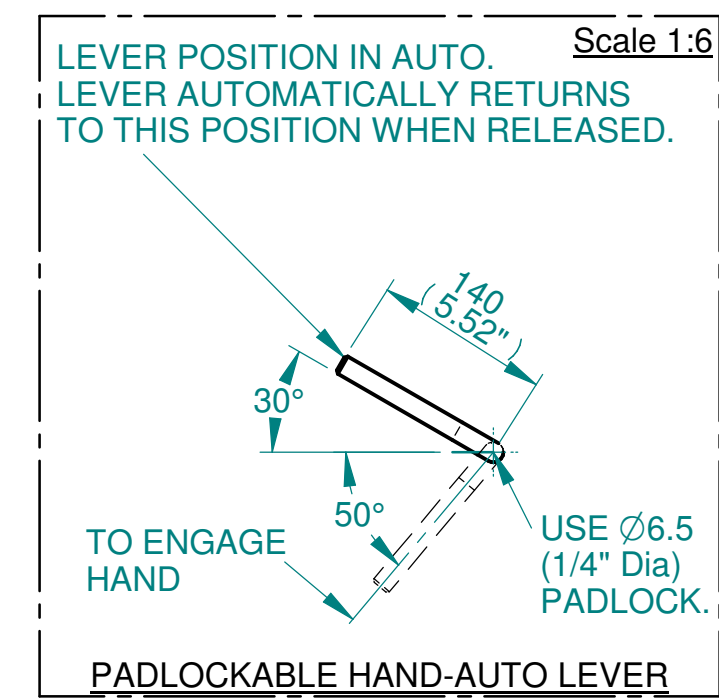
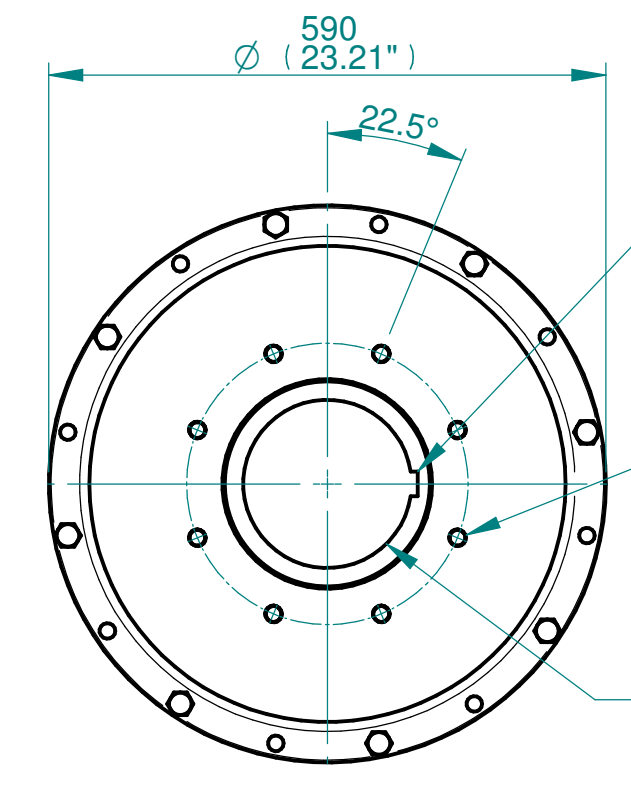
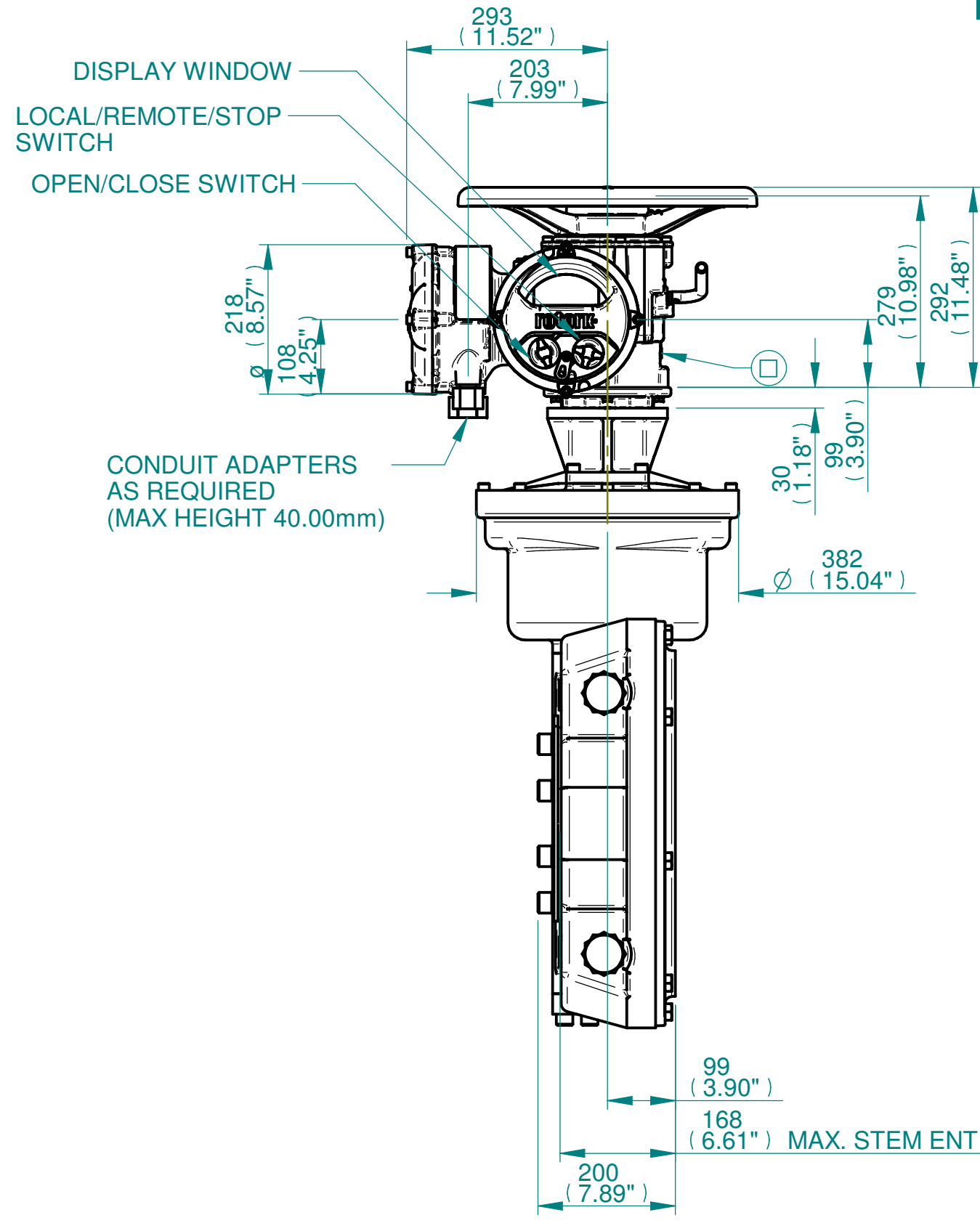
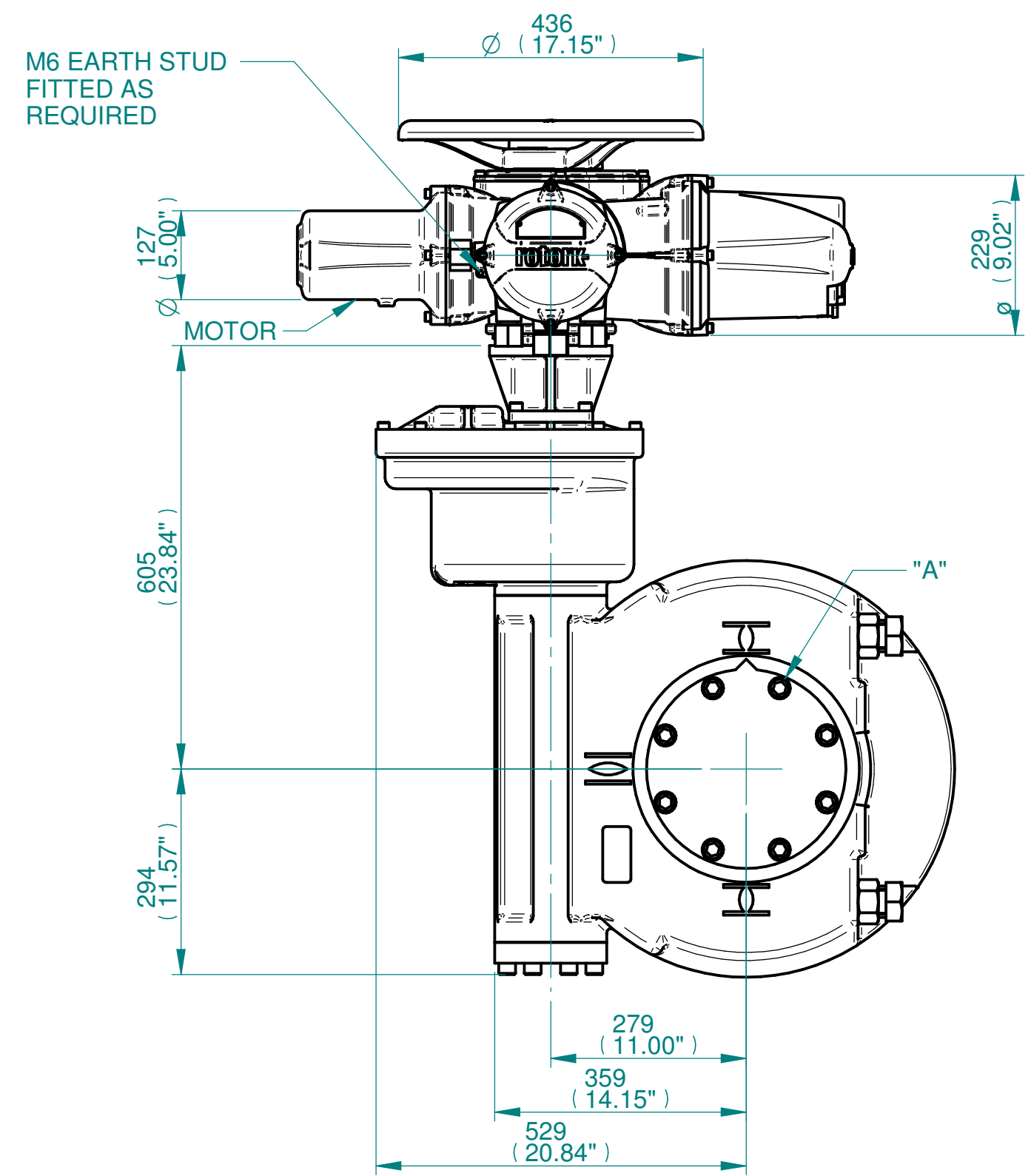

3D Models are available in various formats under the same drawing number



Rotork Controls Limited
Bath, BA1 3JQ, England.
Telephone 01225-733200

Actuator Size: IQ 20/25 IW9 & 96RH/MOW9RH		Gearbox output flange options								Maximum Bore & Key			
Title	IQ20/25, TOP HANDWHEEL, IW9RH / IW96RH / MOW9RH, F/FA30,35 & 40, Ratios 960 - 3000:1 Installation Details	Designation	F30	F35	F40	-	FA30	FA35	FA40	-	Key form	Ø Bore	Key size
Drawn	TED	No. Holes	8	8	8	-	8	8	8	-	Rectangle (BS4235)	178	45 X 25
Checked	NJC	Hole size	M20	M30	M36	-	3/4" UNC	1" UNC	1-1/4" UNC	-	Rectangle (ANSI B17.1)	6-1/2"	1-1/2 X 1"
Date	22-AUG-14	PCD	298	356	406	-	11.75"	14"	16"	-	Square (ANSI B17.1)	6-1/2"	1-1/2" SQ
Ref	SALES	Project Ref	QUOTATION										

Issue	Description
4	OUTPUT FLANGE CHANGE

Scale: 1:8 THIRD ANGLE PROJECTION

A2	Drawing Number	Issue No	Sheet No
I12THWIW9RHSTD		4	1 of 1

1 2 3 4 5 6 7 8 9 10 11 12