

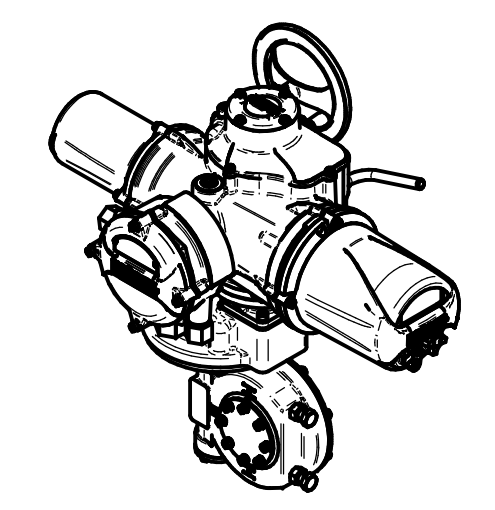

H
G
F
E
D
C
B
A

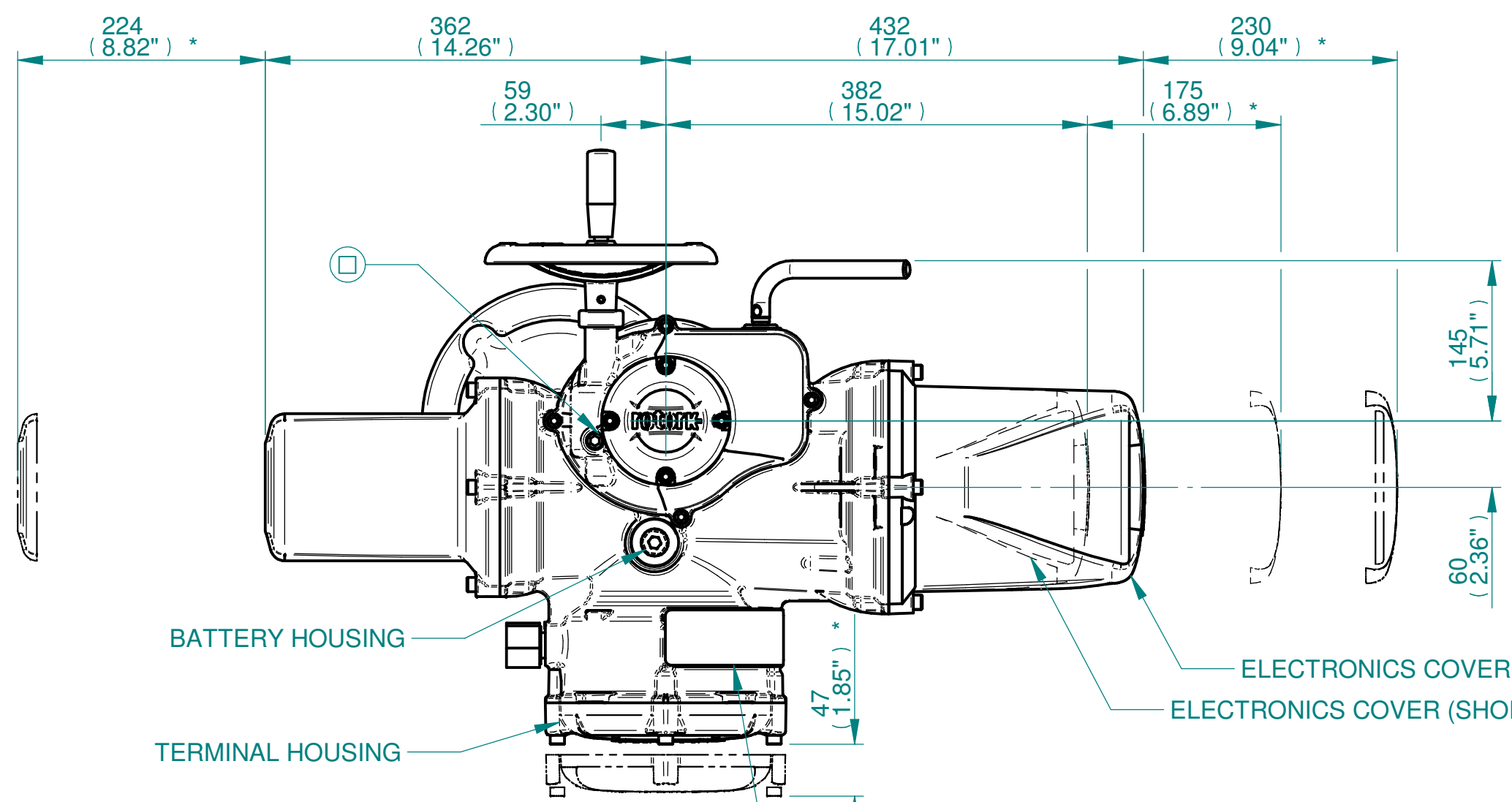

ISOMETRIC VIEW (SCALE 1:12)

NOTES:
 :DIMENSIONS WITH "*" INDICATE COVER REMOVAL ALLOWANCE
 :ELECTRONICS COVER OPTION "*" WILL VARY DEPENDING ON CONFIGURATION
 :NETT WEIGHT = 85kg/187lbs
 :  = OIL FILLER/DRAIN PLUG
 :THE INTERFACE PROVIDED FOR MOUNTING THE ACTUATOR OR SECOND STAGE GEARBOX ONTO THE VALVE SHOULD CONFORM TO GOOD ENGINEERING PRACTICES, ENSURING ADEQUATELY TOLERANCED LIMITS FOR PARALLELISM, PERPENDICULARITY AND CONCENTRICITY.
 :ROTORK CANNOT BE HELD LIABLE FOR DAMAGE TO OUR EQUIPMENT CAUSED BY EXCESSIVE LOADING FROM COVER TUBES. (SEE ALSO PUB000-124)

CONDUIT ENTRIES

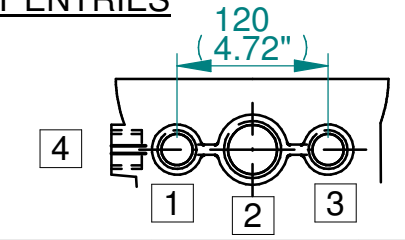

	Hole 1	Hole 2	Hole 3	Hole 4
Size	As Required	As Required	As Required	As Required
Plugged	As Required	As Required	As Required	As Required
Gland	As Required	As Required	As Required	As Required

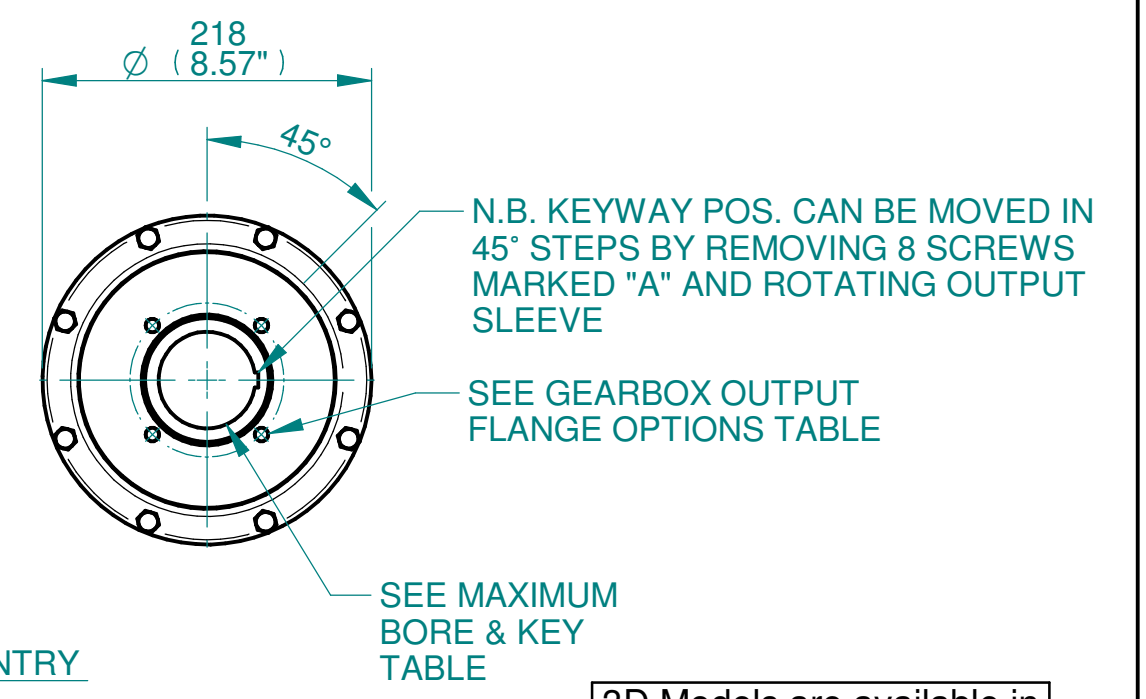
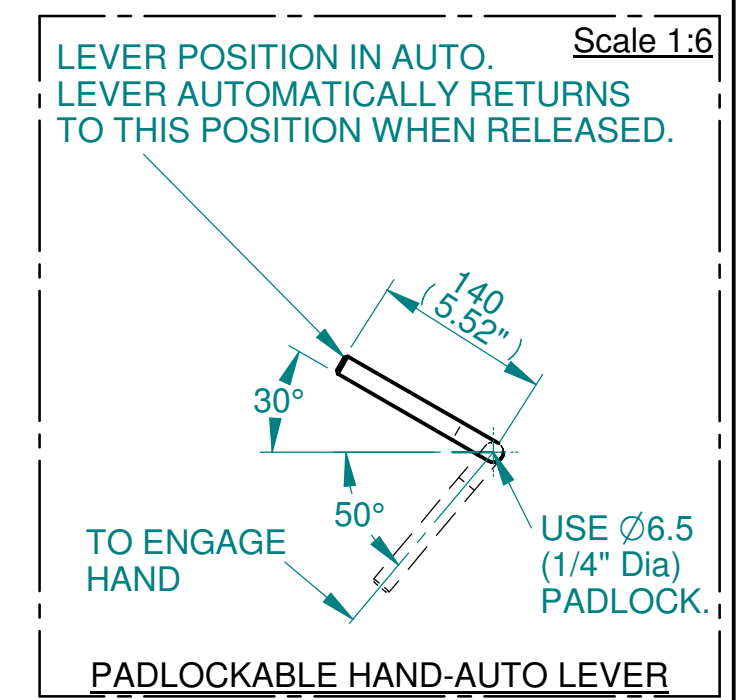
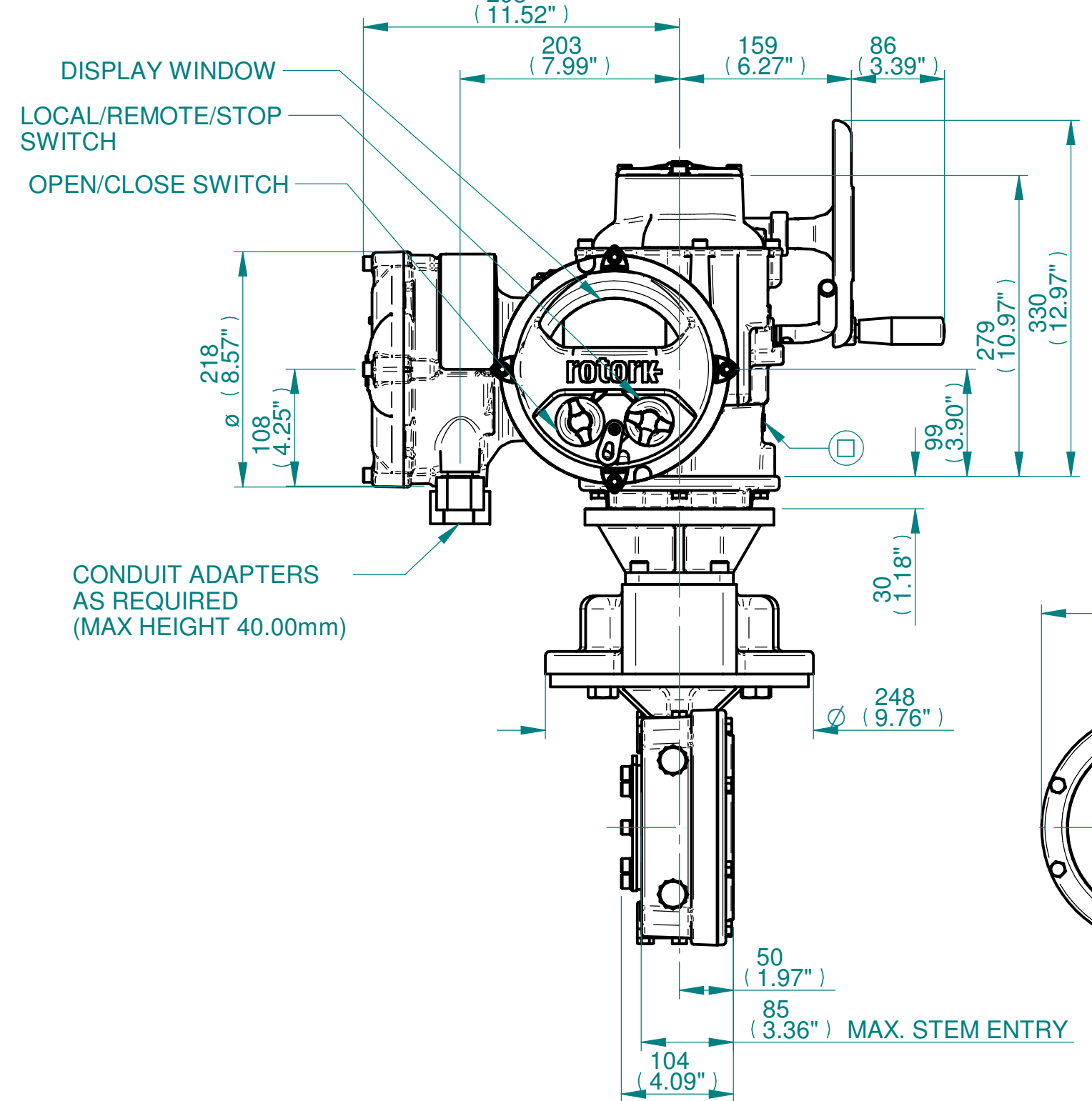
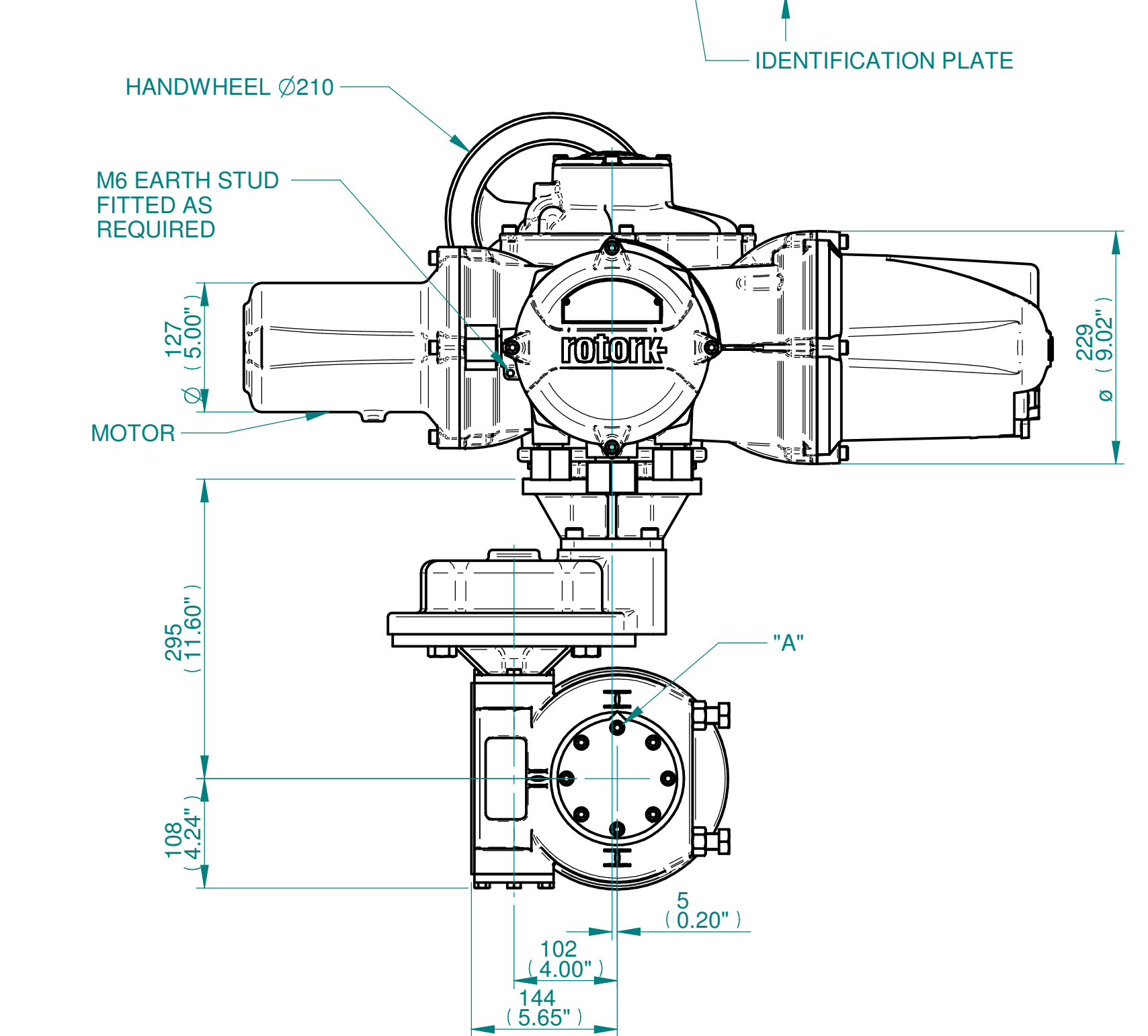

3D Models are available in various formats under the same drawing number



Actuator Size: IQ 20/25 IW4RH/MOW4RH		Gearbox output flange options								Maximum Bore & Key			
Title	IQ20/25,SIDE HANDWHEEL, IW4RH / MOW4RH, F/FA10, 12 & 14, Ratios 140 - 420:1 Installation Details	Designation	F10	F12	F14	-	FA10	FA12	FA14	-	Key form	Ø Bore	Key size
Drawn	TED	No. Holes	4	4	4	-	4	4	4	-	Rectangle (BS4235)	64	18 X 11
Checked	NJC	Hole size	M10	M12	M16	-	3/8" UNC	1/2" UNC	5/8" UNC	-	Rectangle (ANSI B17.1)	2-1/2"	5/8 X 7/16"
Date	22-AUG-14	PCD	102	125	140	-	4"	4.95"	5.5"	-	Square (ANSI B17.1)	2-1/4"	1/2" SQ
Ref	SALES Project Ref QUOTATION												

Issue	Description
4	OUTPUT FLANGE CHANGE

Scale: 1:5  THIRD ANGLE PROJECTION

Drawing Number	Issue No	Sheet No
I12SHWIW4RHSTD	4	1 of 1

1 2 3 4 5 6 7 8 9 10 11 12