

H  
G  
F  
E  
D  
C  
B  
A

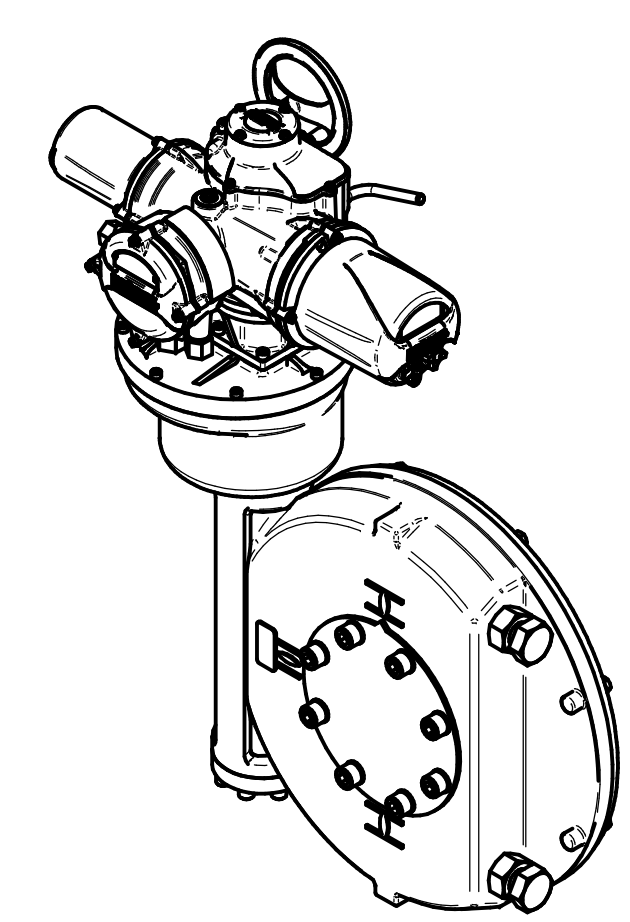

ISOMETRIC VIEW (SCALE 1:12)

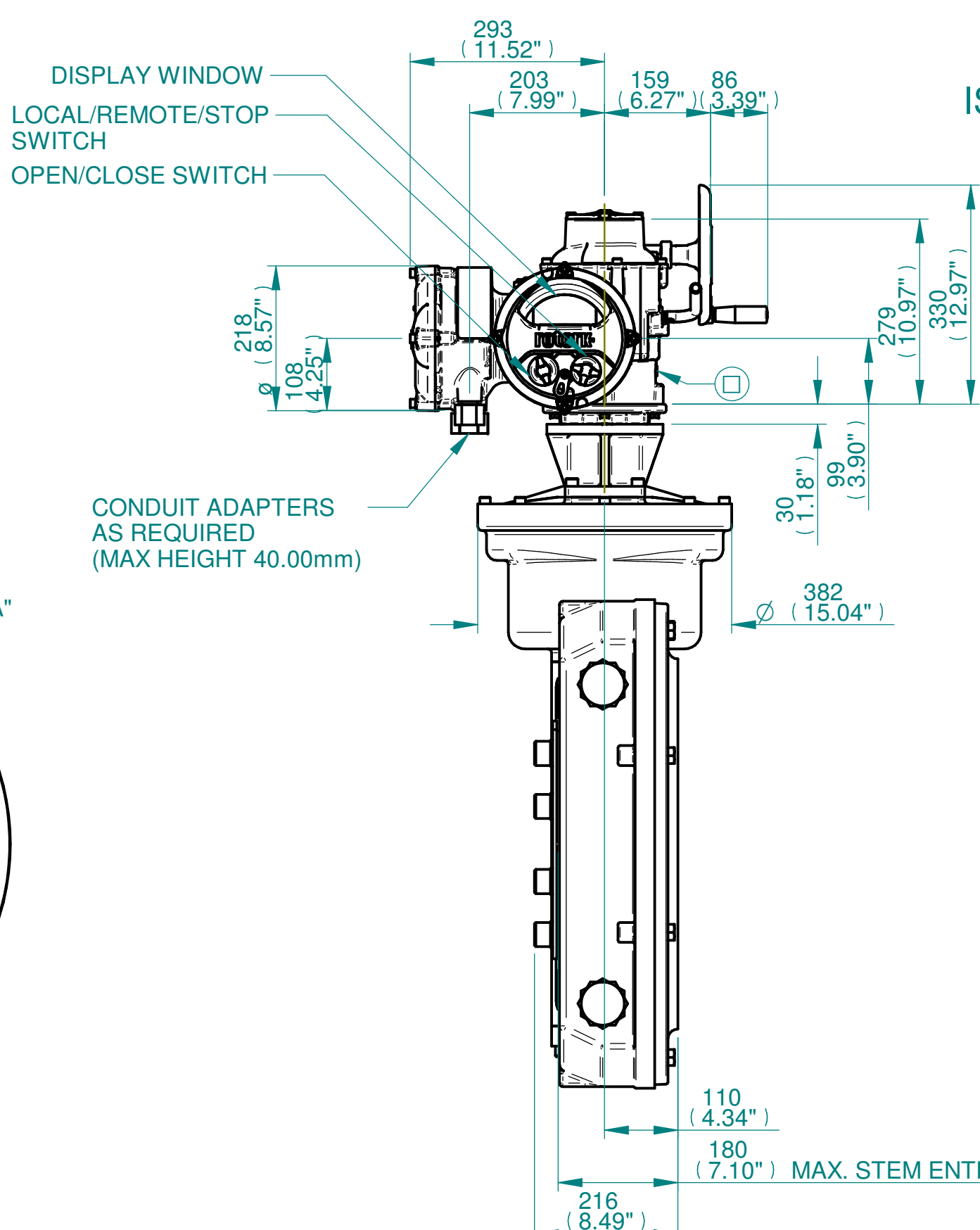
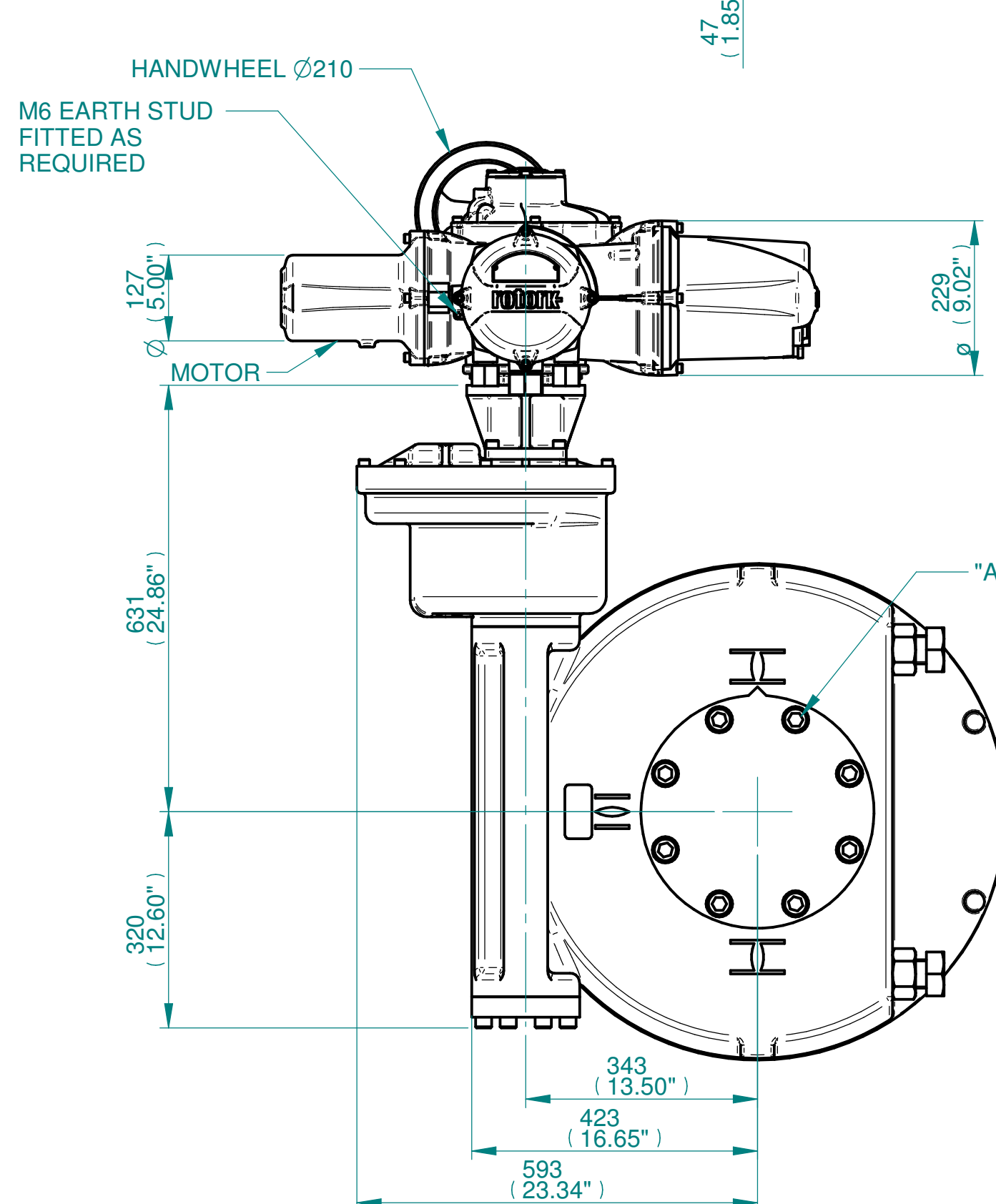
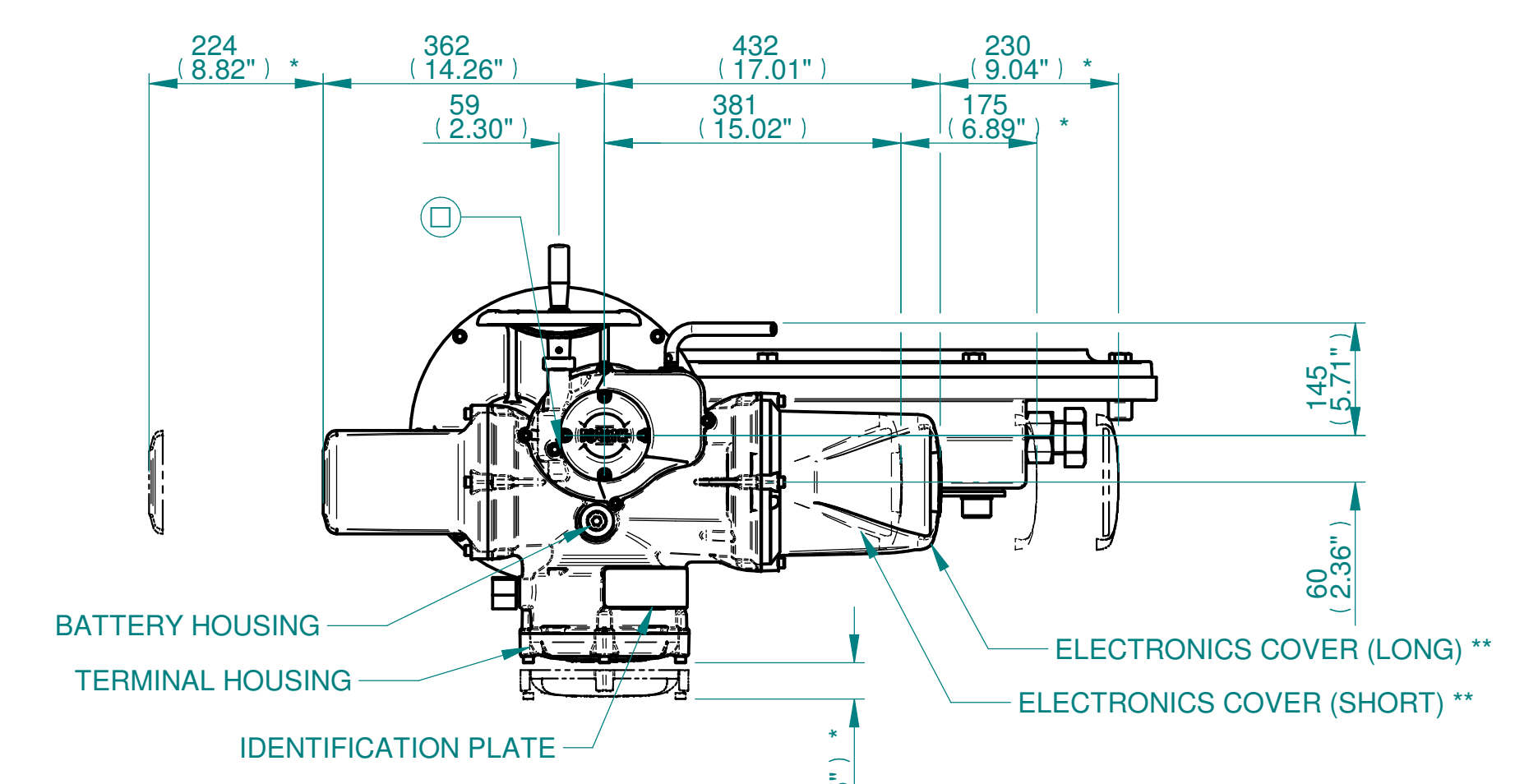
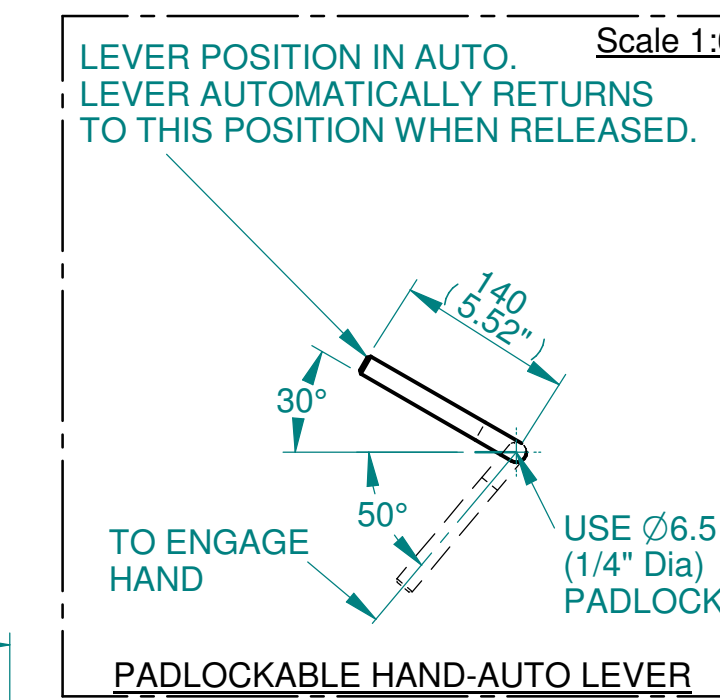
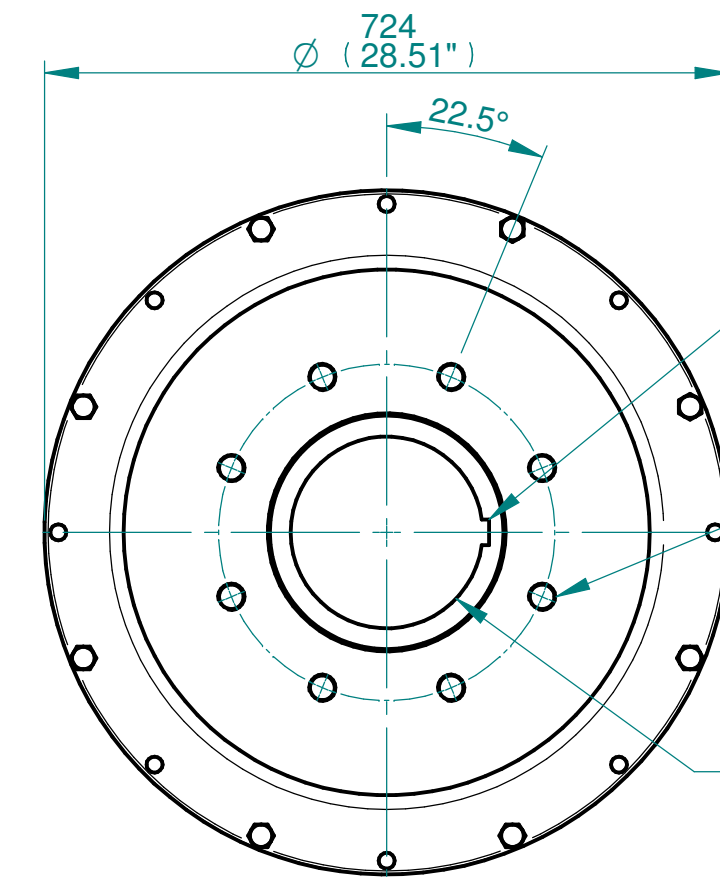

N.B. KEYWAY POS. CAN BE MOVED IN 45° STEPS BY REMOVING 8 SCREWS MARKED "A" AND ROTATING OUTPUT SLEEVE

SEE GEARBOX OUTPUT FLANGE OPTIONS TABLE

SEE MAXIMUM BORE & KEY TABLE

**NOTES:**  
 :DIMENSIONS WITH \*\*\* INDICATE COVER REMOVAL ALLOWANCE  
 :ELECTRONICS COVER OPTION \*\*\*\*\* WILL VARY DEPENDING ON CONFIGURATION  
 :NETT WEIGHT = 460kg/1014lbs  
 : = OIL FILLER/DRAIN PLUG  
 :THE INTERFACE PROVIDED FOR MOUNTING THE ACTUATOR OR SECOND STAGE GEARBOX ONTO THE VALVE SHOULD CONFORM TO GOOD ENGINEERING PRACTICES, ENSURING ADEQUATELY TOLERANCED LIMITS FOR PARALLELISM, PERPENDICULARITY AND CONCENTRICITY.  
 :ROTORK CANNOT BE HELD LIABLE FOR DAMAGE TO OUR EQUIPMENT CAUSED BY EXCESSIVE LOADING FROM COVER TUBES. (SEE ALSO PUB000-123)

**CONDUIT ENTRIES**

	Hole 1	Hole 2	Hole 3	Hole 4
Size	As Required	As Required	As Required	As Required
Plugged	As Required	As Required	As Required	As Required
Gland	As Required	As Required	As Required	As Required

3D Models are available in various formats under the same drawing number



Actuator Size: IQ 20/25 IW10,106R/MOW10R		Gearbox output flange options								Maximum Bore & Key			
Title	IQ20/25, SIDE HANDWHEEL, IW10R / IW106R / MOW10R, F/FA35,40 & 48, Ratios 180 - 3700:1 Installation Details	Designation	F35	F40	F48	-	FA35	FA40	FA48	-	Key form	Ø Bore	Key size
Drawn	TED	No. Holes	8	8	12 NOT SHOWN	-	8	8	12 NOT SHOWN	-	Rectangle (BS4235)	203	50 X 28
Checked	NJC	Hole size	M30	M36	M36	-	1" UNC	1-1/4" UNC	1-1/4" UNC	-	Rectangle (ANSI B17.1)	7-5/8"	2 X 1-1/2"
Date	22-AUG-14	PCD	356	406	483	-	14"	16"	19"	-	Square (ANSI B17.1)	7-3/8"	1-3/4" SQ
Ref	SALES Project Ref QUOTATION												

Issue	Description
4	OUTPUT FLANGE CHANGE

Scale: 1:8 THIRD ANGLE PROJECTION

Drawing Number	Issue No	Sheet No
I12SHWIW10RSTD	4	1 of 1

1 2 3 4 5 6 7 8 9 10 11 12