

ISOMETRIC VIEW
1:10

NOTES:
 : DIMENSIONS WITH "*" INDICATE COVER REMOVAL ALLOWANCE
 : ELECTRONICS COVER OPTION "****" WILL VARY DEPENDING ON CONFIGURATION
 : NETT WEIGHT = 134kg/295lbs
 : = OIL FILLER/DRAIN PLUG
 : THE INTERFACE PROVIDED FOR MOUNTING THE ACTUATOR OR SECOND STAGE GEARBOX ONTO THE VALVE SHOULD CONFORM TO GOOD ENGINEERING PRACTICES, ENSURING ADEQUATELY TOLERANCED LIMITS FOR PARALLELISM, PERPENDICULARITY AND CONCENTRICITY.
 : ROTORK CANNOT BE HELD LIABLE FOR DAMAGE TO OUR EQUIPMENT CAUSED BY EXCESSIVE LOADING FROM COVER TUBES. (SEE ALSO PUB000-124)

CONDUIT ENTRIES

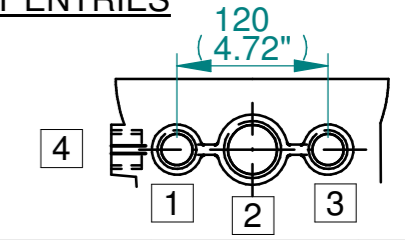

	Hole 1	Hole 2	Hole 3	Hole 4
Size	As Required	As Required	As Required	As Required
Plugged	As Required	As Required	As Required	As Required
Gland	As Required	As Required	As Required	As Required

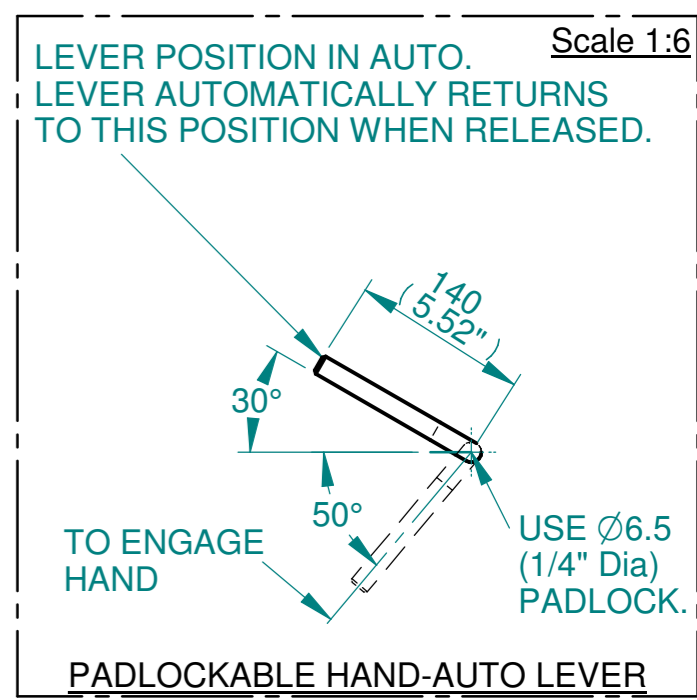
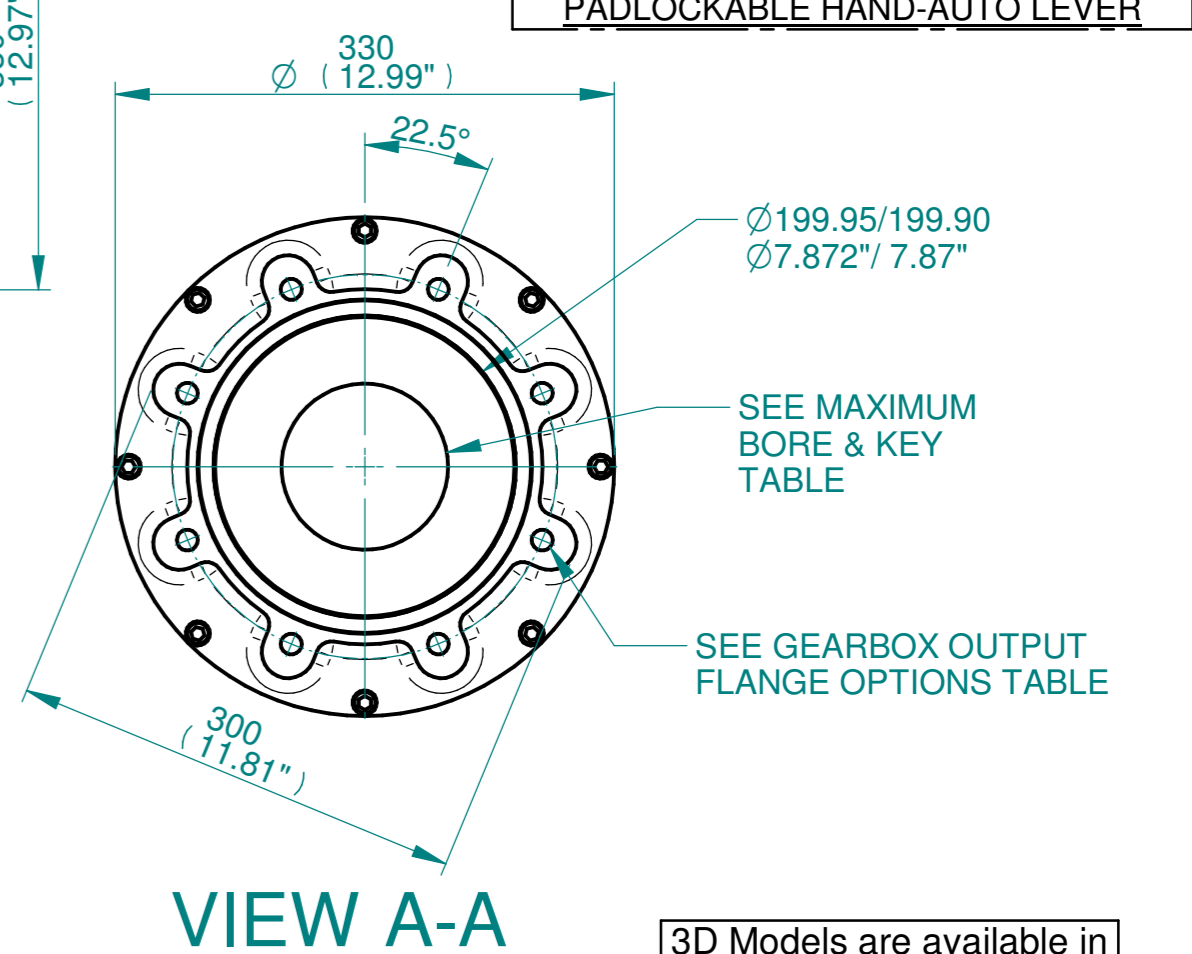
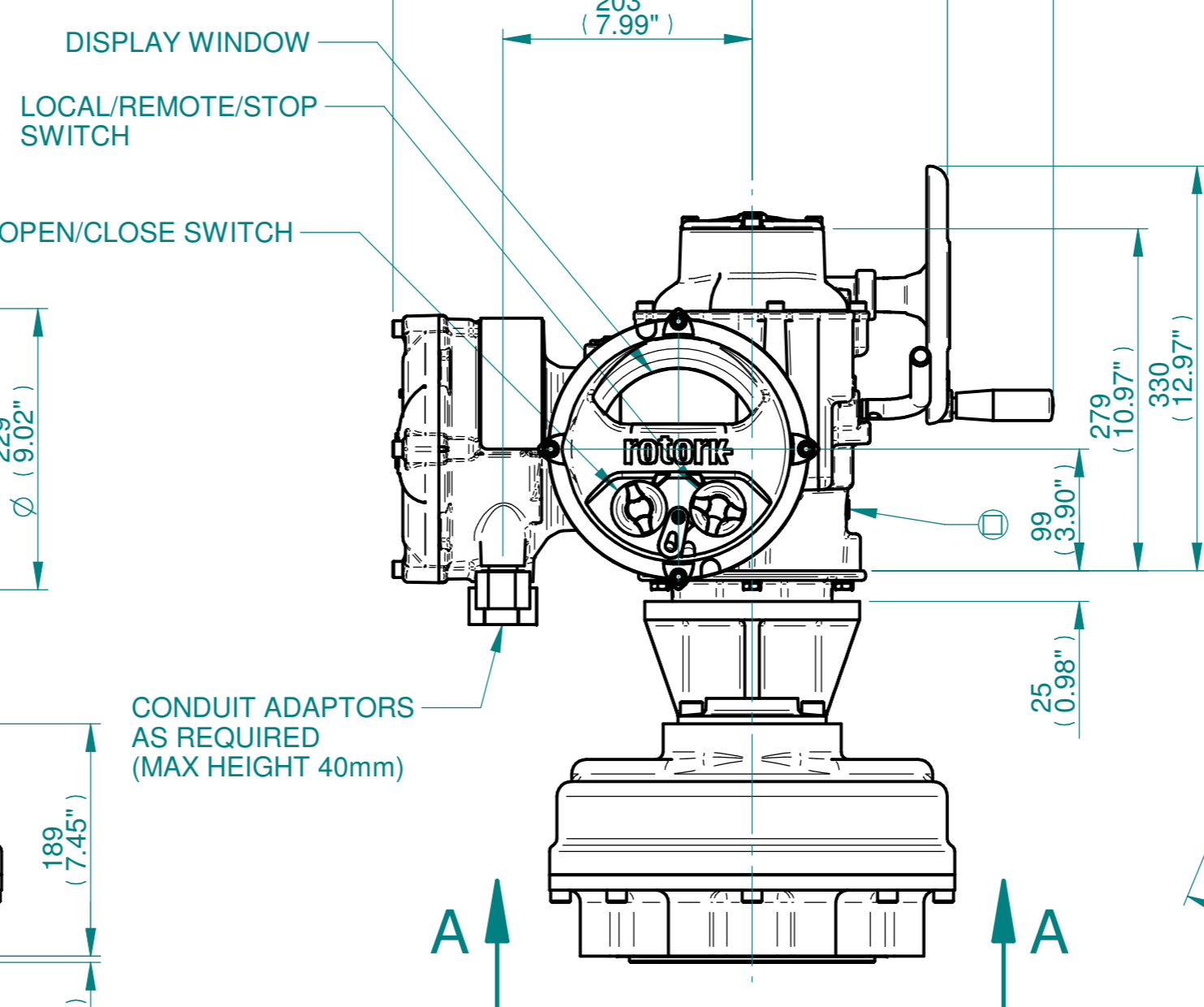
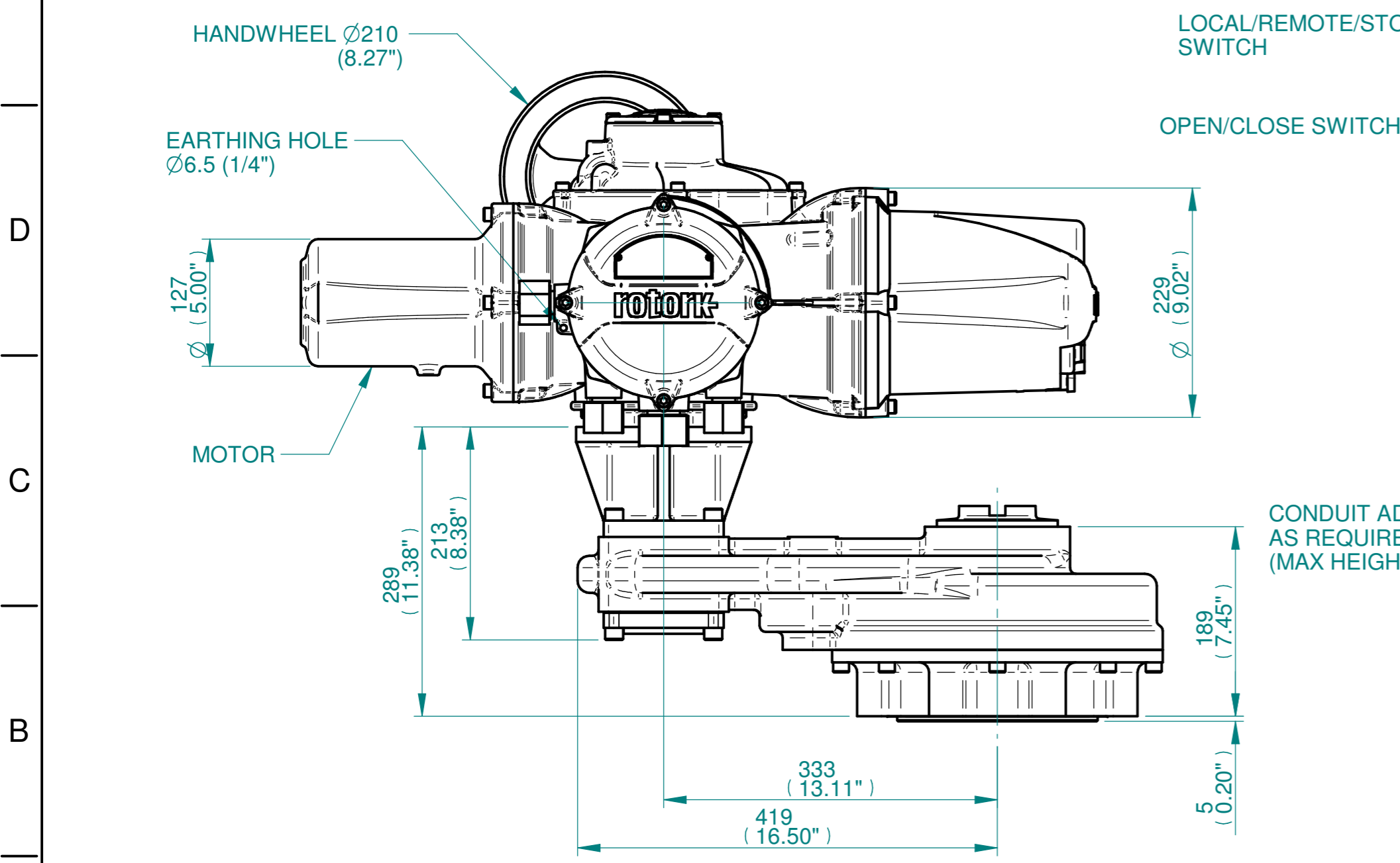

www.rotork.com Rotork Controls Limited Bath, BA1 3JQ, England. Telephone 01225-733200	Actuator Size: IQ19/20/25, IS9		Gearbox output flange options							Maximum Bore & Key					
	Title IQ19/20/25, SIDE HANDWHEEL, IS9, F25, FA25, Ratios 4:1,6:1,8:1,10:1,12:1 15:1 Installation Details		Designation	F25	-	-	-	-	FA25	-	-	-	Key form	Ø Bore	Key size
	Drawn DH Checked JBA Date FEB 19		No. Holes	8	-	-	-	-	8	-	-	-	Rectangle (BS4235)	76	22 x 14
	Ref SALES Project Ref QUOTATION		Hole size	M16	-	-	-	-	5/8" UNC	-	-	-	-	-	-
		PCD	254	-	-	-	-	10"	-	-	-	-	-	-	

3D Models are available in various formats under the same drawing number

Issue	Description
1	FIRST ISSUE
Scale: 1:5 THIRD ANGLE PROJECTION	
A2	Drawing Number Issue No Sheet No
I12SHWIS9STD	1 1 of 1