

NOTES:
 : DIMENSIONS WITH "*" INDICATE COVER REMOVAL ALLOWANCE
 : ELECTRONICS COVER OPTION "*" WILL VARY DEPENDING ON CONFIGURATION
 : NETT WEIGHT = 82kg/181lbs
 : = OIL FILLER/DRAIN PLUG
 : THE INTERFACE PROVIDED FOR MOUNTING THE ACTUATOR OR SECOND STAGE GEARBOX ONTO THE VALVE SHOULD CONFORM TO GOOD ENGINEERING PRACTICES, ENSURING ADEQUATELY TOLERANCED LIMITS FOR PARALLELISM, PERPENDICULARITY AND CONCENTRICITY.
 : ROTORK CANNOT BE HELD LIABLE FOR DAMAGE TO OUR EQUIPMENT CAUSED BY EXCESSIVE LOADING FROM COVER TUBES. (SEE ALSO PUB000-124)

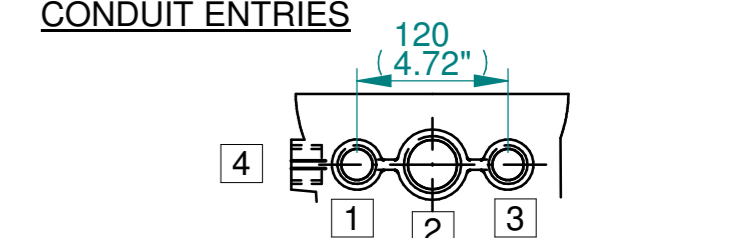

	Hole 1	Hole 2	Hole 3	Hole 4
Size	As Required	As Required	As Required	As Required
Plugged	As Required	As Required	As Required	As Required
Gland	As Required	As Required	As Required	As Required

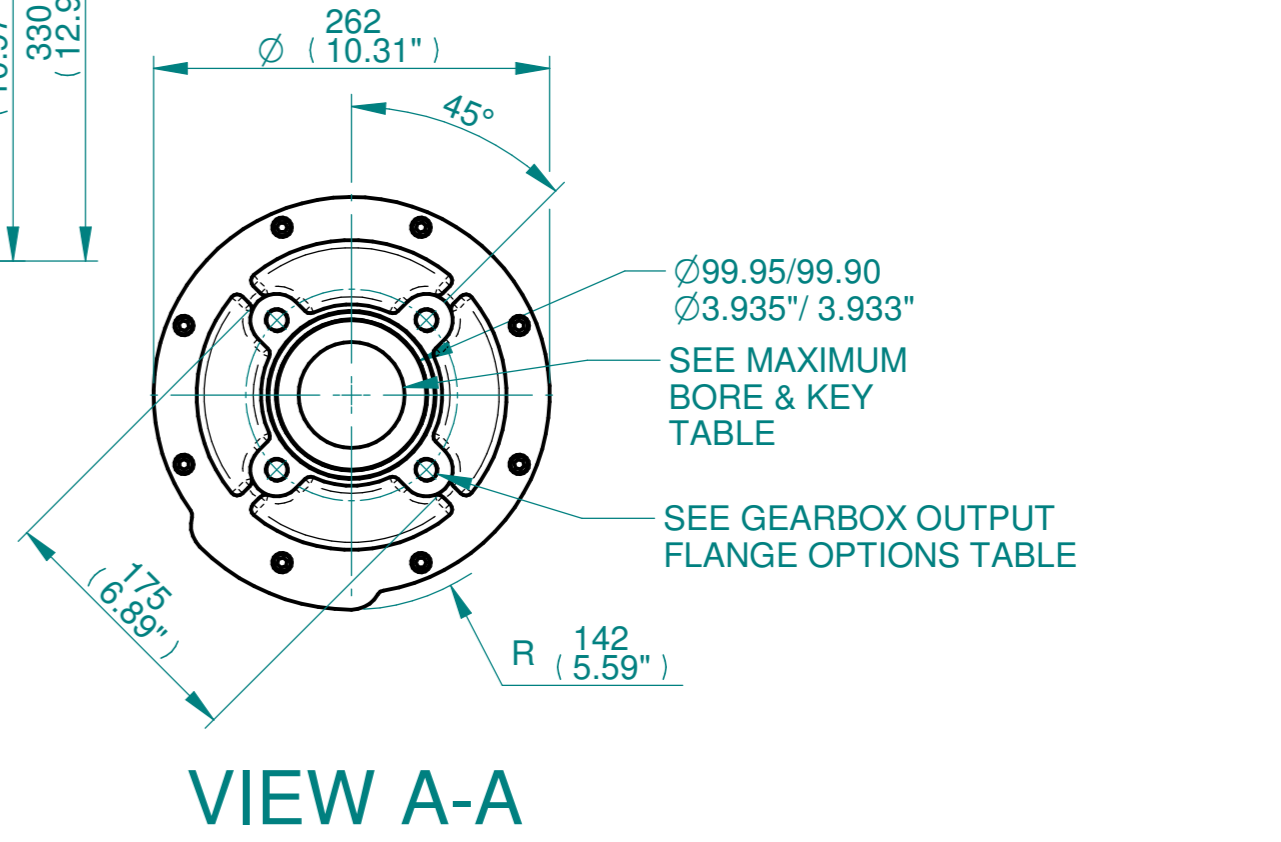
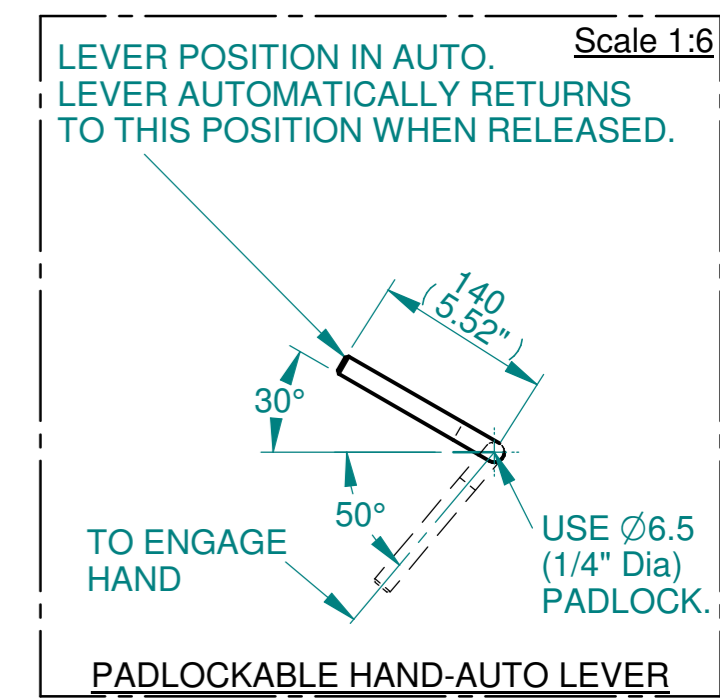
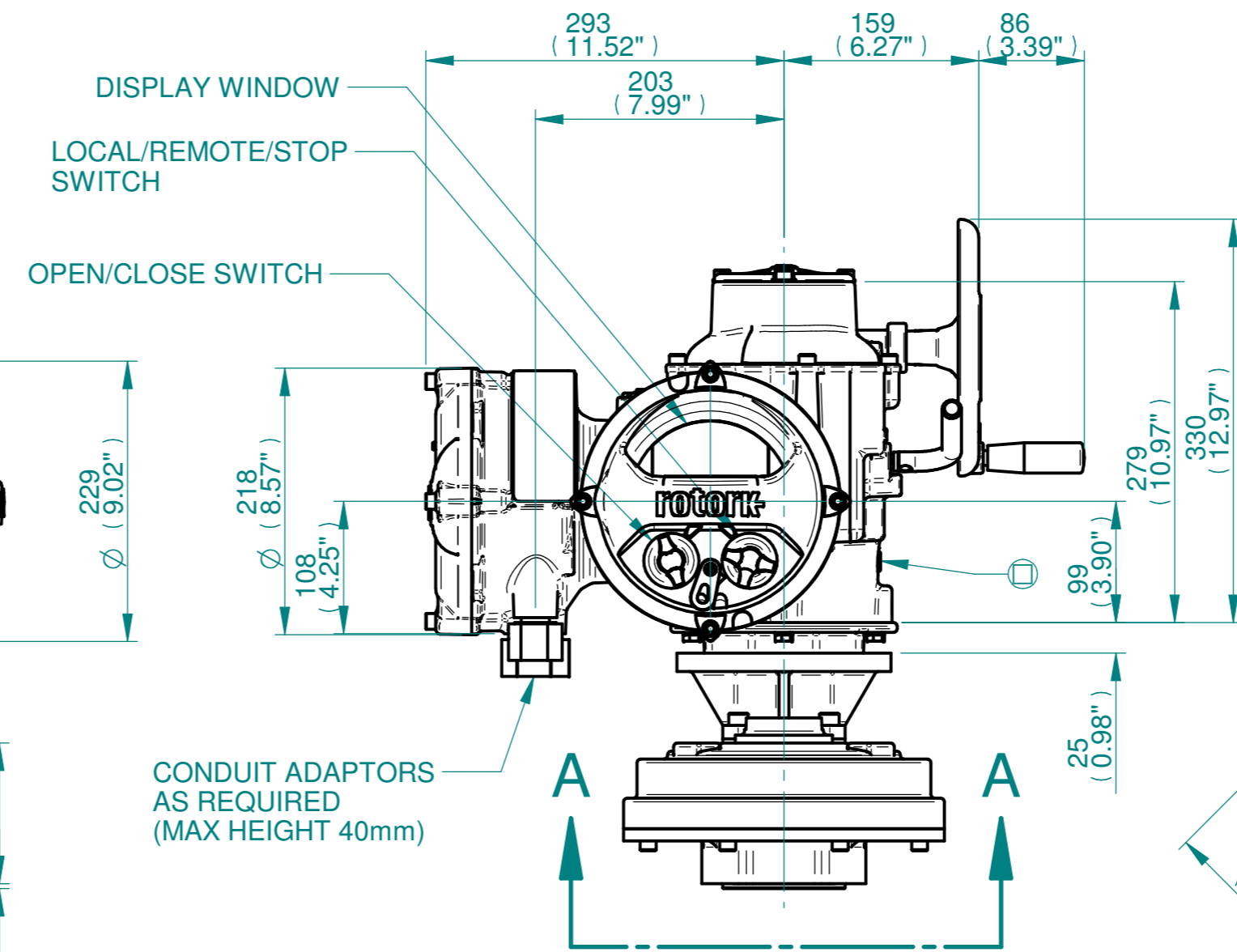
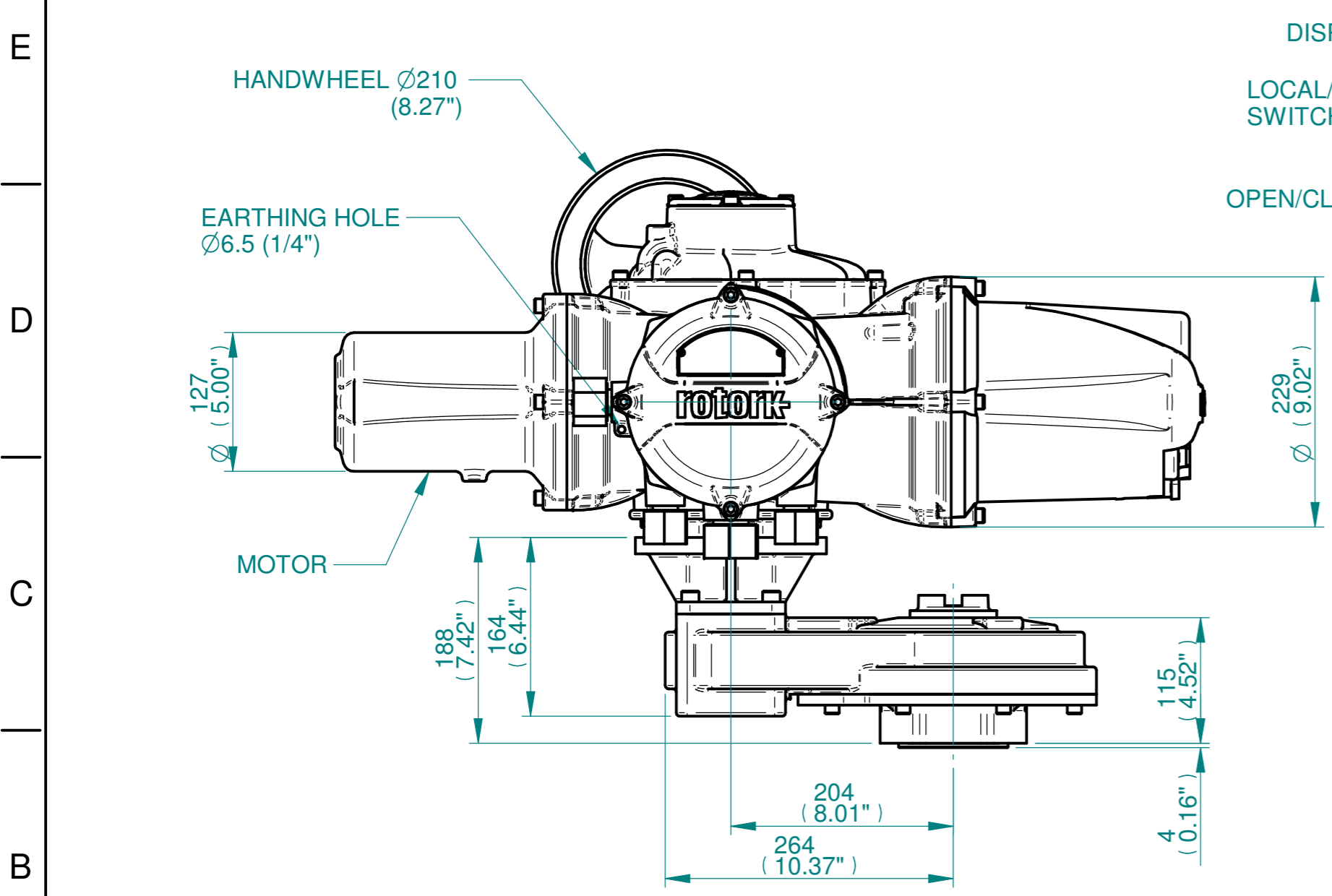

rotork
 www.rotork.com
 Rotork Controls Limited
 Bath, BA1 3JQ, England.
 Telephone 01225-733200

Actuator Size: IQ19/20/25, IS5		Gearbox output flange options								Maximum Bore & Key			
Title	IQ19/20/25, SIDE HANDWHEEL, IS5, F14, FA14, Ratios 2:1,3:1,4:1 & 6:1 Installation Details	Designation	F14	-	-	-	FA14	-	-	-	Key form	Ø Bore	Key size
Drawn	DH	No. Holes	4	-	-	-	4	-	-	-	Rectangle (BS4235)	52	16 x 10
Checked	JBA	Hole size	M16	-	-	-	5/8" UNC	-	-	-	-	-	-
Date	DEC 18	PCD	140	-	-	-	51/2"	-	-	-	-	-	-
Ref	SALES	Project Ref	QUOTATION	-	-	-	-	-	-	-	-	-	-

3D Models are available in various formats under the same drawing number

Issue	Description
1	FIRST ISSUE

Scale: 1:5 THIRD ANGLE PROJECTION

Drawing Number	Issue No	Sheet No
I12SHWIS5STD	1	1 of 1