

H
G
F
E
D
C
B
A

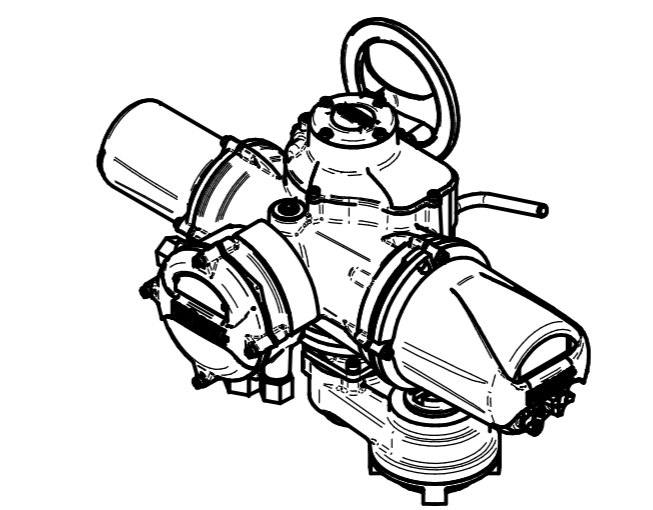

ISOMETRIC VIEW
1:10

NOTES:
 :DIMENSIONS WITH "*" INDICATE COVER REMOVAL ALLOWANCE
 :ELECTRONICS COVER OPTION "*" WILL VARY DEPENDING ON CONFIGURATION
 :NETT WEIGHT = 72kg/159lbs
 : = OIL FILLER/DRAIN PLUG
 :THE INTERFACE PROVIDED FOR MOUNTING THE ACTUATOR OR SECOND STAGE GEARBOX ONTO THE VALVE SHOULD CONFORM TO GOOD ENGINEERING PRACTICES, ENSURING ADEQUATELY TOLERANCED LIMITS FOR PARALLELISM, PERPENDICULARITY AND CONCENTRICITY.
 :ROTORK CANNOT BE HELD LIABLE FOR DAMAGE TO OUR EQUIPMENT CAUSED BY EXCESSIVE LOADING FROM COVER TUBES. (SEE ALSO PUB000-124)

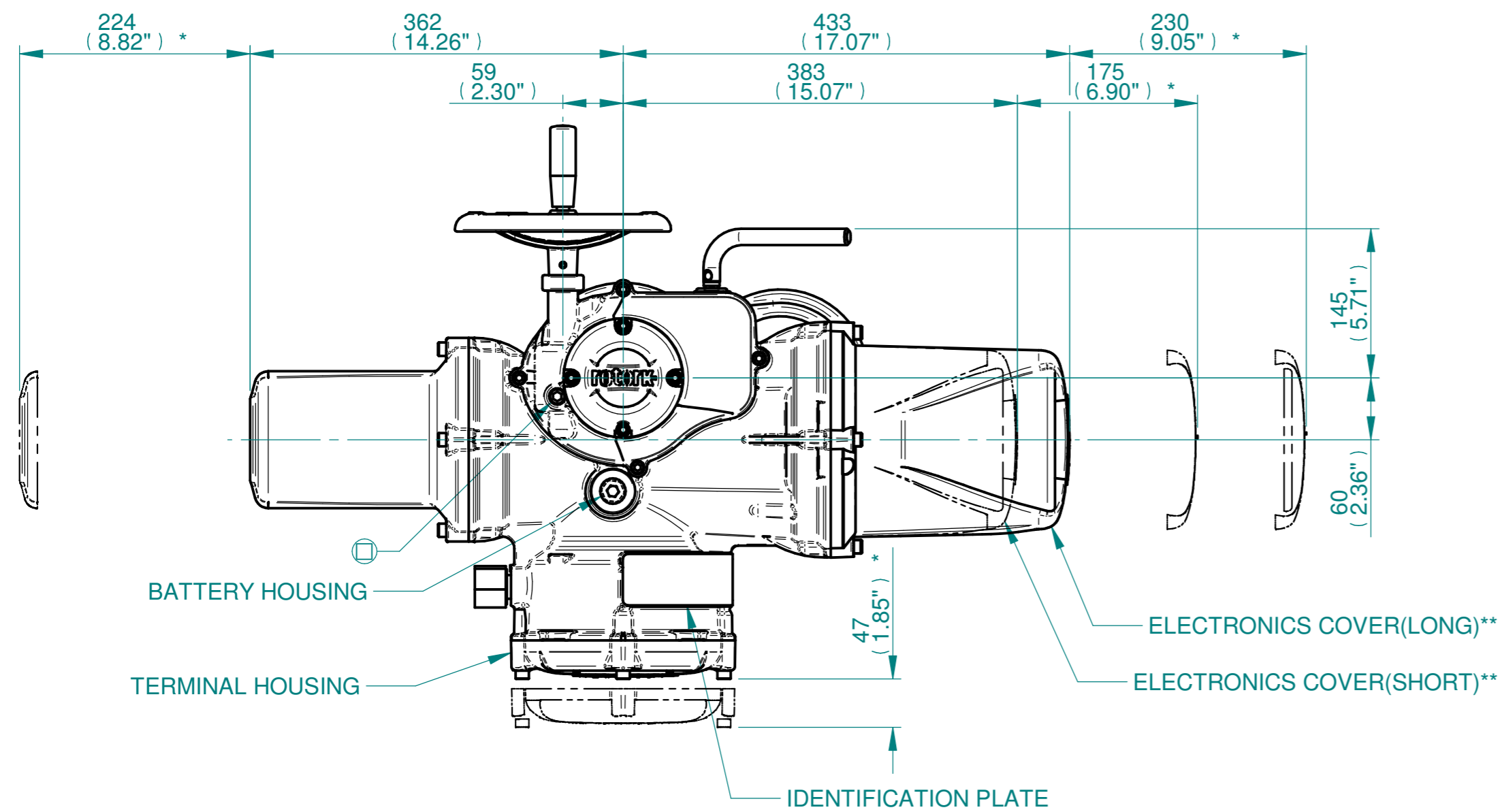
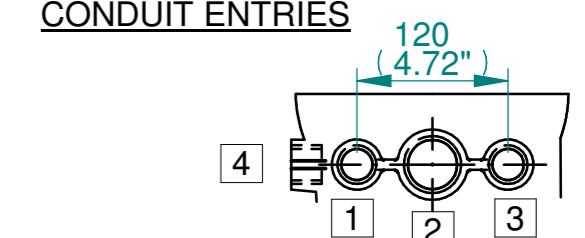

	Hole 1	Hole 2	Hole 3	Hole 4
Size	As Required	As Required	As Required	As Required
Plugged	As Required	As Required	As Required	As Required
Gland	As Required	As Required	As Required	As Required

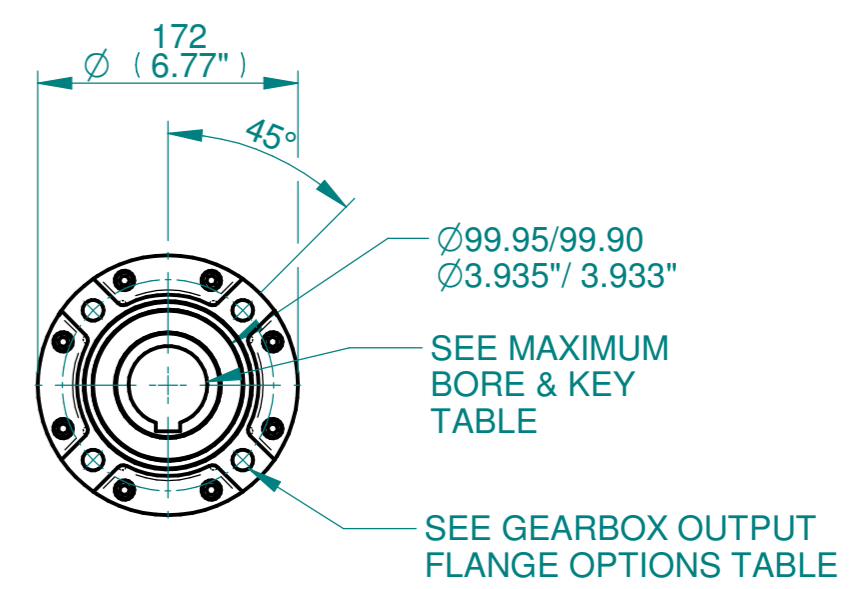
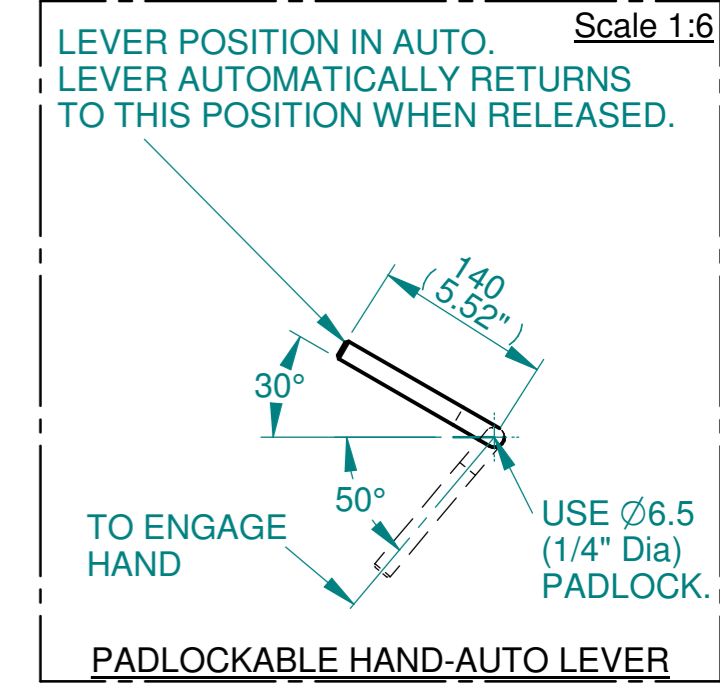
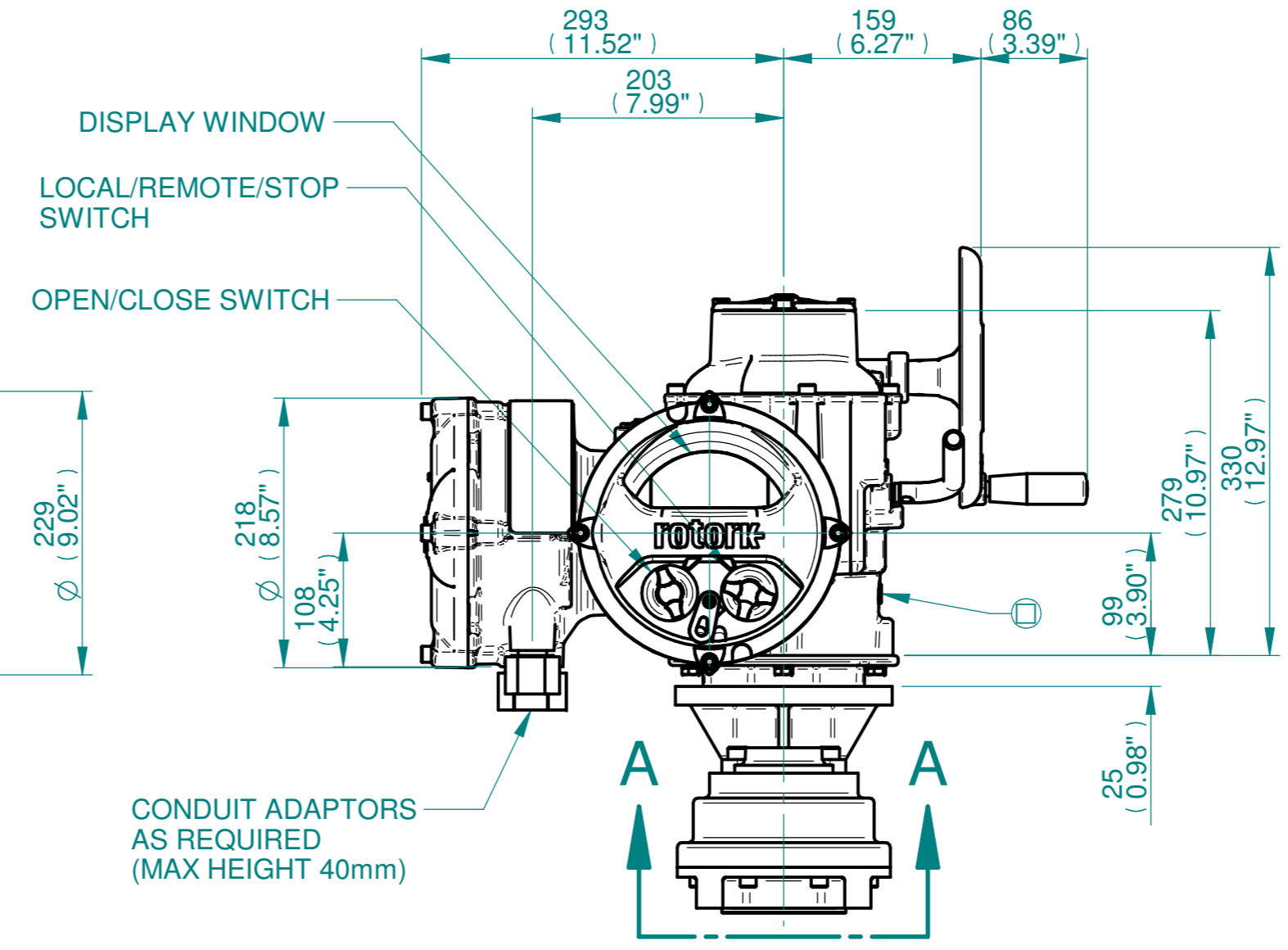
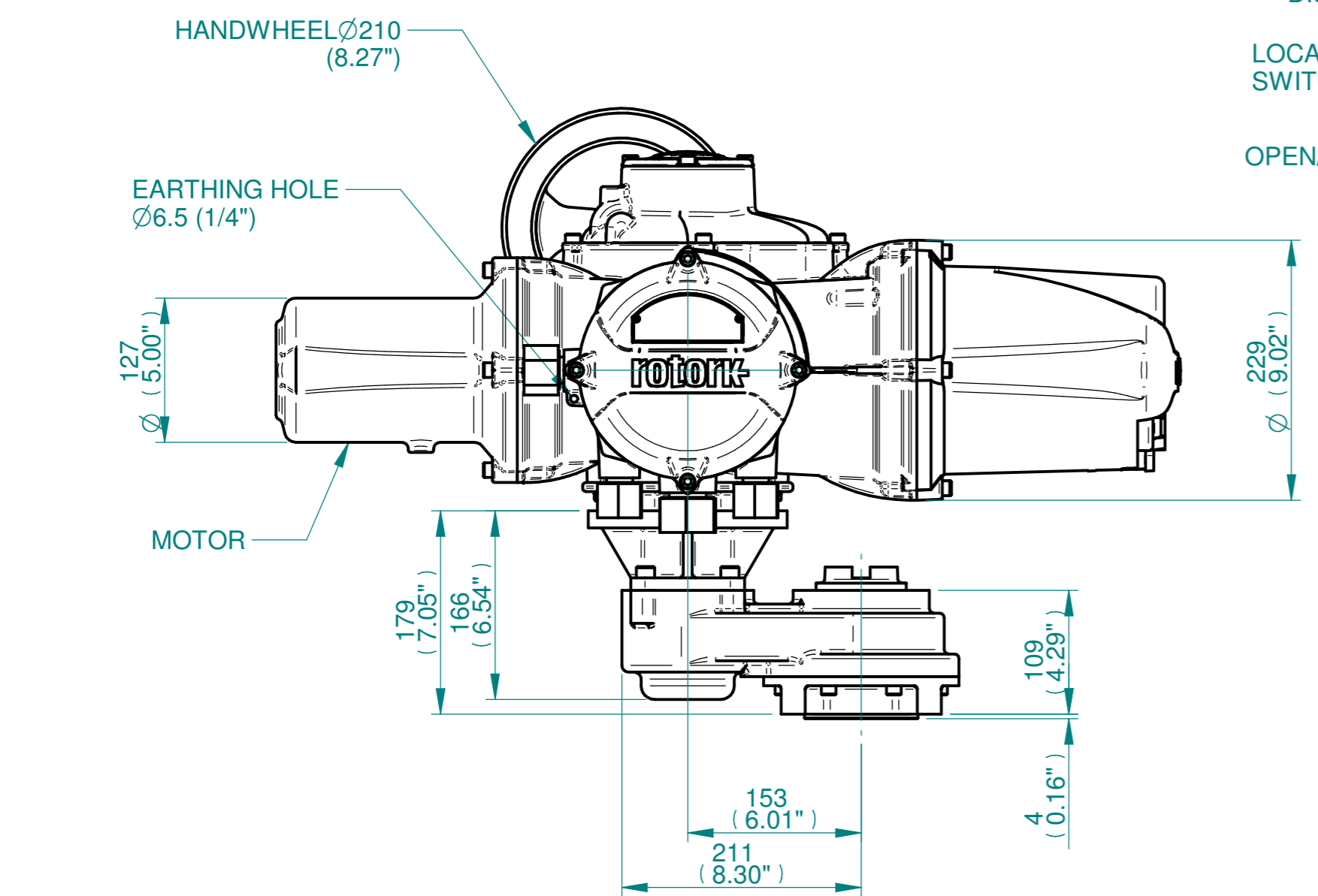

VIEW A-A

3D Models are available in various formats under the same drawing number

rotork
www.rotork.com
Rotork Controls Limited
Bath, BA1 3JQ, England.
Telephone 01225-733200

Actuator Size: IQ19/20/25, IS3		Gearbox output flange options								Maximum Bore & Key			
Title	IQ19/20/25, SIDE HANDWHEEL, IS3, F14, FA14, Ratios 1:1, 2:1 & 3:1 Installation Details	Designation	F14	-	-	-	FA14	-	-	-	Key form	Ø Bore	Key size
Drawn	DH	No. Holes	4	-	-	-	4	-	-	-	Rectangle (BS4235)	52	16 x 10
Checked	JBA	Hole size	M16	-	-	-	5/8" UNC	-	-	-	-	-	-
Date	DEC 18	PCD	140	-	-	-	51/2"	-	-	-	-	-	-
Ref	SALES	Project Ref	QUOTATION	-	-	-	-	-	-	-	-	-	-

Issue	Description
1	FIRST ISSUE

Scale: 1:5 THIRD ANGLE PROJECTION

Drawing Number	Issue No	Sheet No
I12SHWIS3STD	1	1 of 1

1 2 3 4 5 6 7 8 9 10 11 12