

ISOMETRIC VIEW  
(SCALE 1:12)

**NOTES:**  
 :DIMENSIONS WITH "\*" INDICATE COVER REMOVAL ALLOWANCE  
 :ELECTRONICS COVER OPTION "\*\*\*\*" WILL VARY DEPENDING ON CONFIGURATION  
 :NETT WEIGHT = 70kg/154lbs  
 : = OIL FILLER/DRAIN PLUG  
 :THE INTERFACE PROVIDED FOR MOUNTING THE ACTUATOR OR SECOND STAGE GEARBOX ONTO THE VALVE SHOULD CONFORM TO GOOD ENGINEERING PRACTICES, ENSURING ADEQUATELY TOLERANCED LIMITS FOR PARALLELISM, PERPENDICULARITY AND CONCENTRICITY.  
 :ROTORK CANNOT BE HELD LIABLE FOR DAMAGE TO OUR EQUIPMENT CAUSED BY EXCESSIVE LOADING FROM COVER TUBES. (SEE ALSO PUB000-124)

**CONDUIT ENTRIES**

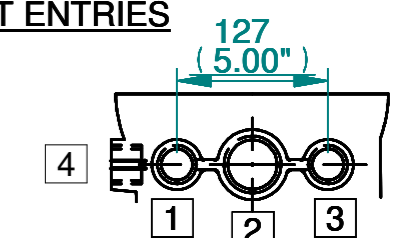

	Hole 1	Hole 2	Hole 3	Hole 4
Size	As Required	As Required	As Required	As Required
Plugged	As Required	As Required	As Required	As Required
Gland	As Required	As Required	As Required	As Required

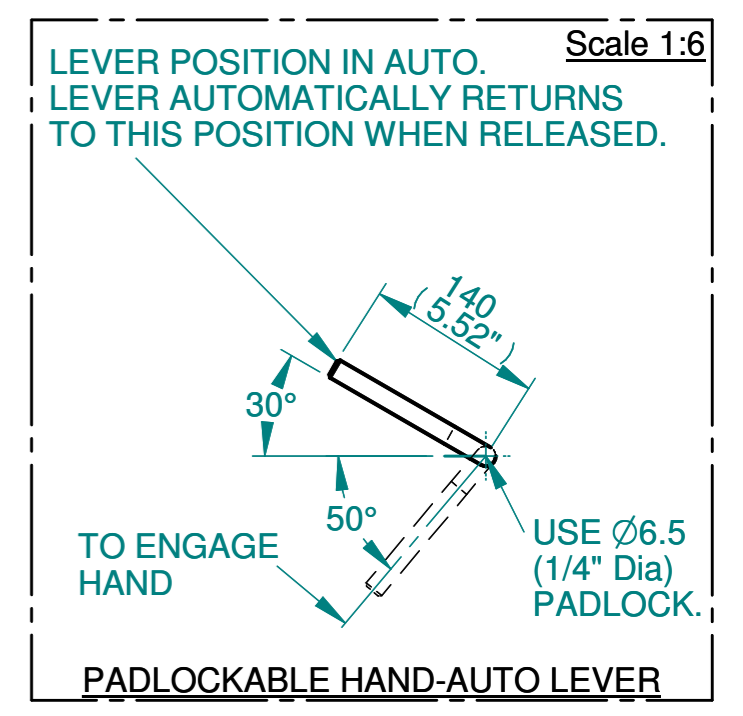
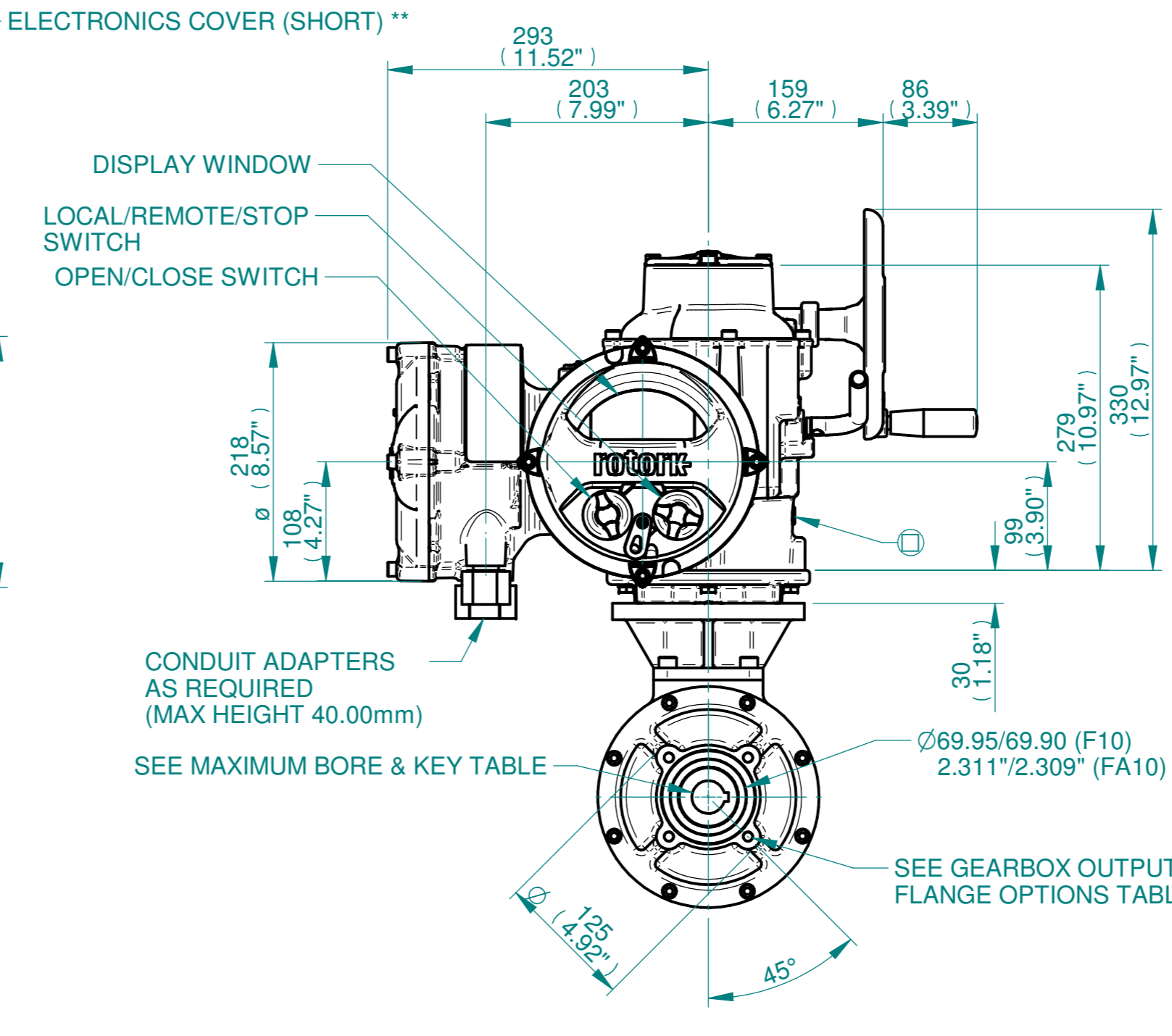

**rotork**  
www.rotork.com

Rotork Controls Limited  
Bath, BA1 3JQ, England.  
Telephone 01225-733200

Actuator Size: IQ 20/25, IB4, F10/FA10

Title IQ20/25, SIDE HANDWHEEL, IB4, F10/FA10, Ratios 2:1,3:1,4:1 & 6:1 Installation Details

Drawn JLF Checked NJC Date 11-MAR-15

Ref SALES Project Ref QUOTATION

Gearbox output flange options										Maximum Bore & Key		
Designation	F10	-	-	-	-	FA10	-	-	-	Key form	Ø Bore	Key size
No. Holes	4	-	-	-	-	4	-	-	-	Rectangle (BS4235)	40	12 X 8
Hole size	M10	-	-	-	-	3/8" UNC	-	-	-	Rectangle (ANSI B17.1)	1-5/8"	3/8 X 1/4"
PCD	102	-	-	-	-	4"	-	-	-	Square (ANSI B17.1)	1-1/2"	3/8"

Issue	Description
3	F14 Base change

Scale: 1:5

THIRD ANGLE PROJECTION

Drawing Number	Issue No	Sheet No
I12SHWIB4STD	3	1 of 1