

H
G
F
E
D
C
B
A

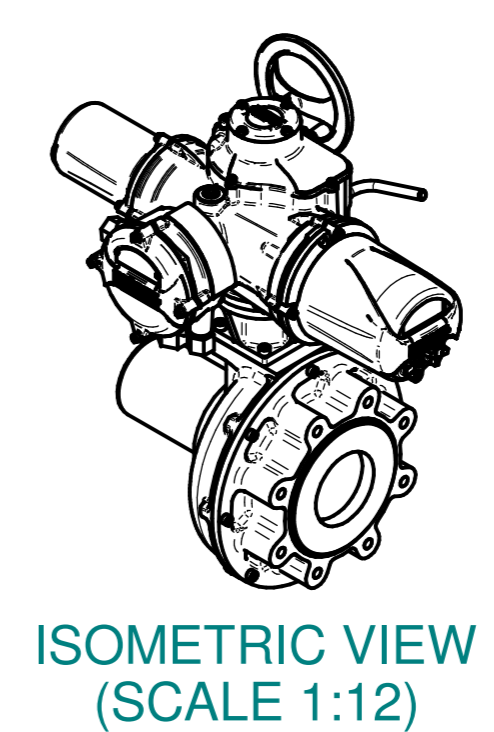

NOTES:
 :DIMENSIONS WITH "*" INDICATE COVER REMOVAL ALLOWANCE
 :ELECTRONICS COVER OPTION "****" WILL VARY DEPENDING ON CONFIGURATION
 :NETT WEIGHT = F25:179kg/395lbs, F30:189kg/417lbs
 : = OIL FILLER/DRAIN PLUG
 :THE INTERFACE PROVIDED FOR MOUNTING THE ACTUATOR OR SECOND STAGE GEARBOX ONTO THE VALVE SHOULD CONFORM TO GOOD ENGINEERING PRACTICES, ENSURING ADEQUATELY TOLERANCED LIMITS FOR PARALLELISM, PERPENDICULARITY AND CONCENTRICITY.
 :ROTORK CANNOT BE HELD LIABLE FOR DAMAGE TO OUR EQUIPMENT CAUSED BY EXCESSIVE LOADING FROM COVER TUBES. (SEE ALSO PUB000-124)

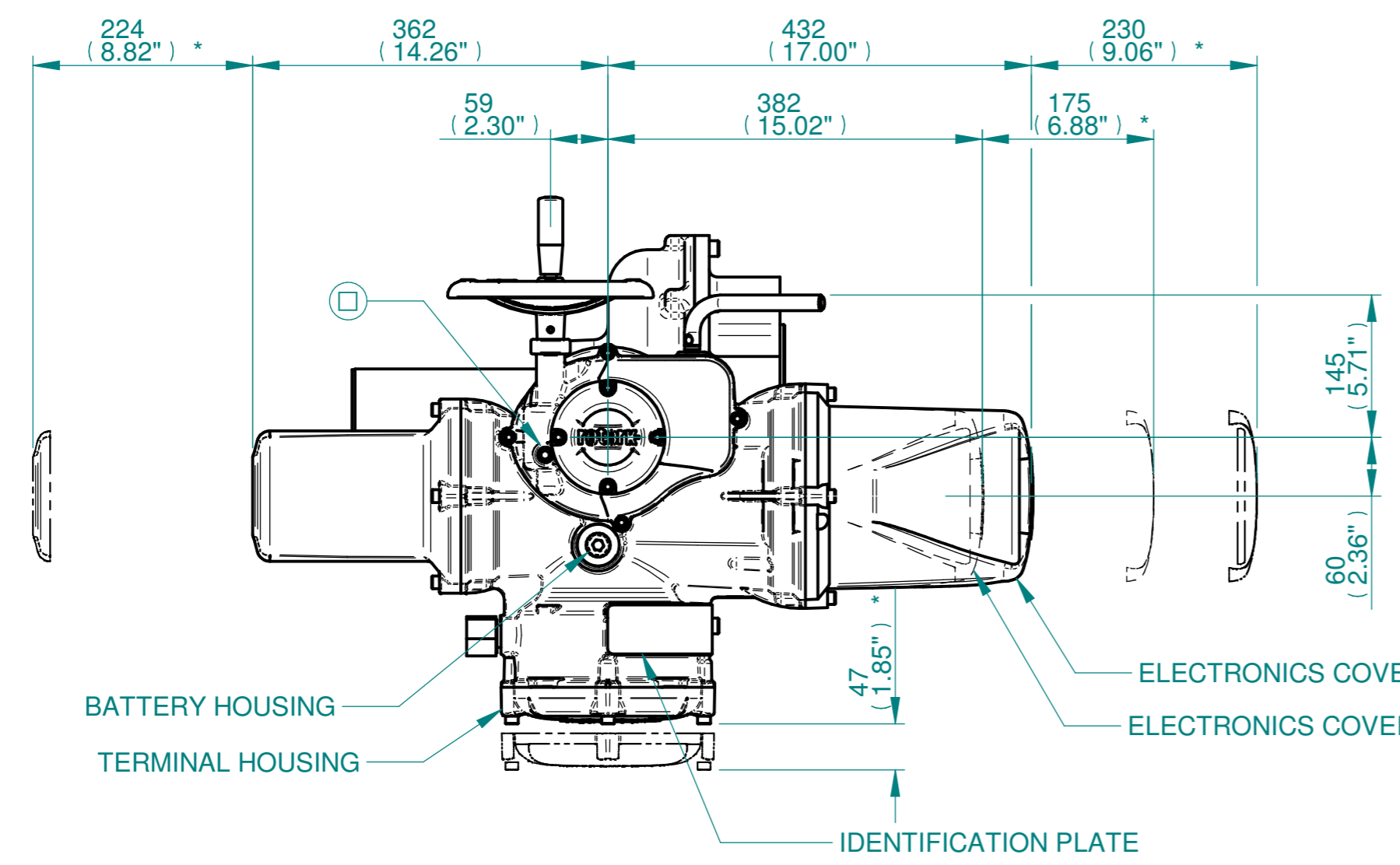
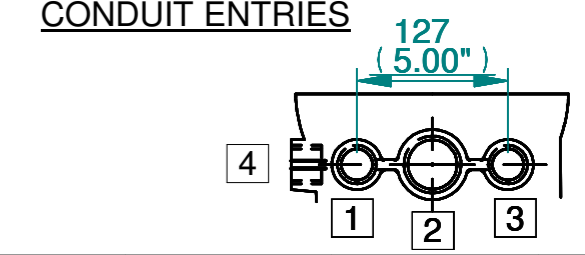

	Hole 1	Hole 2	Hole 3	Hole 4
Size	As Required	As Required	As Required	As Required
Plugged	As Required	As Required	As Required	As Required
Gland	As Required	As Required	As Required	As Required

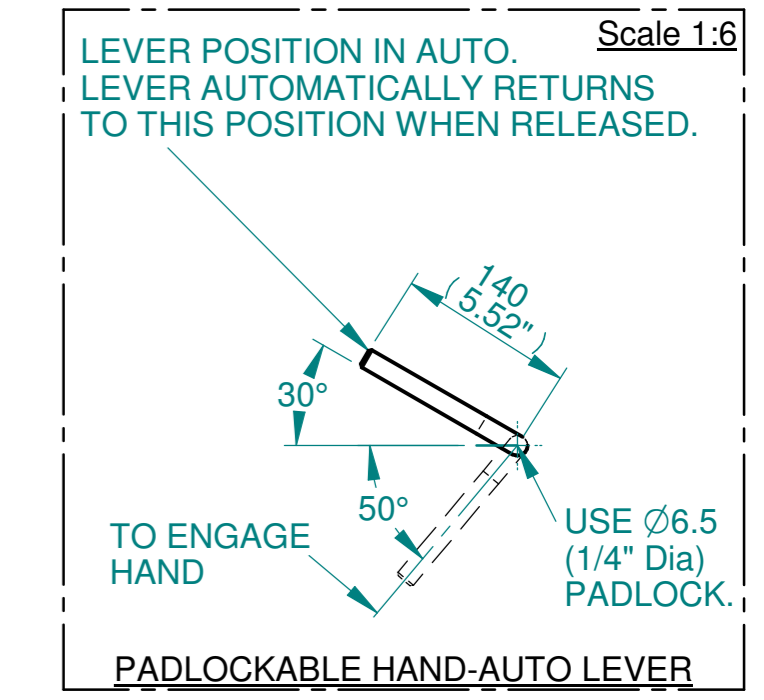
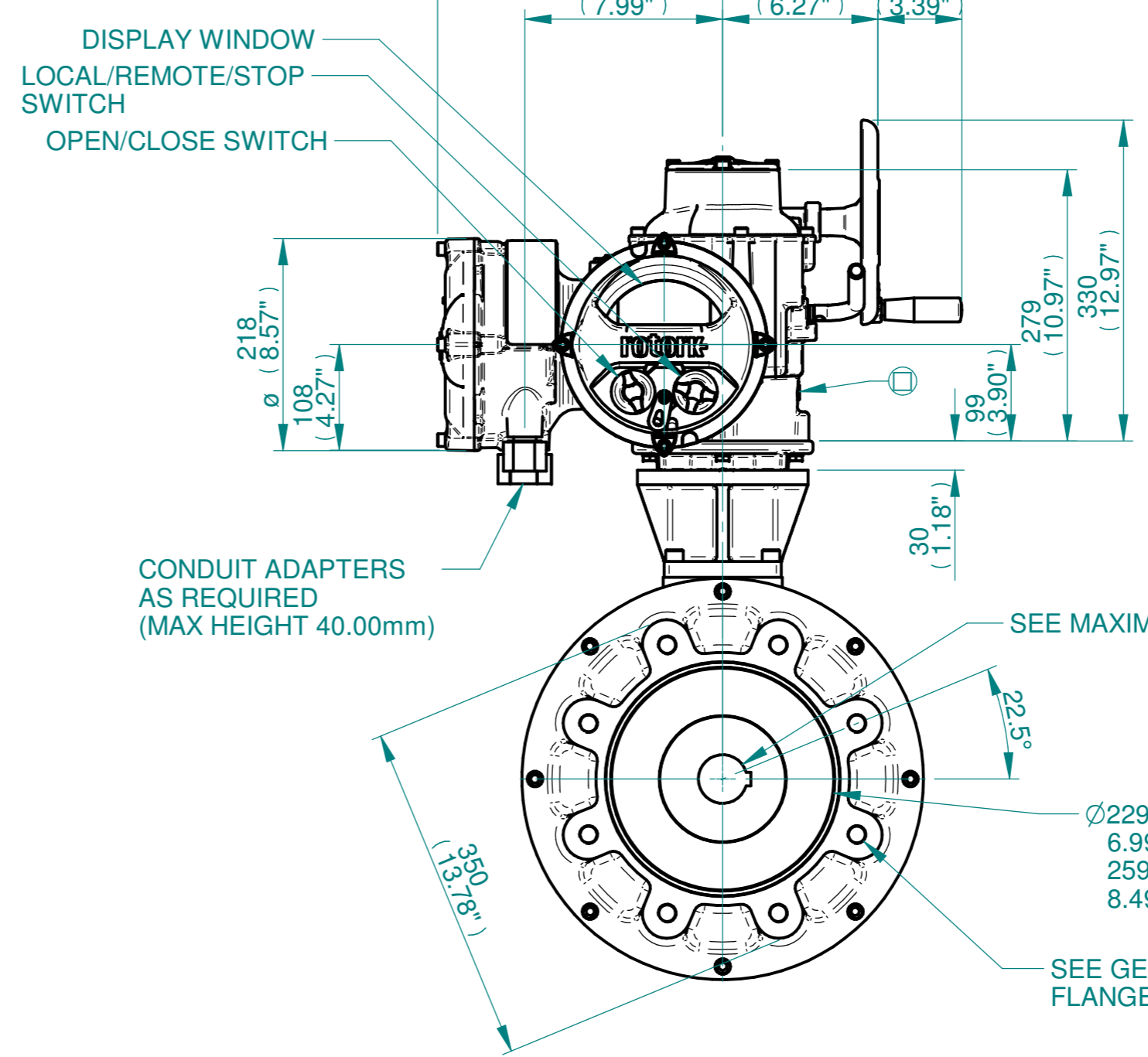
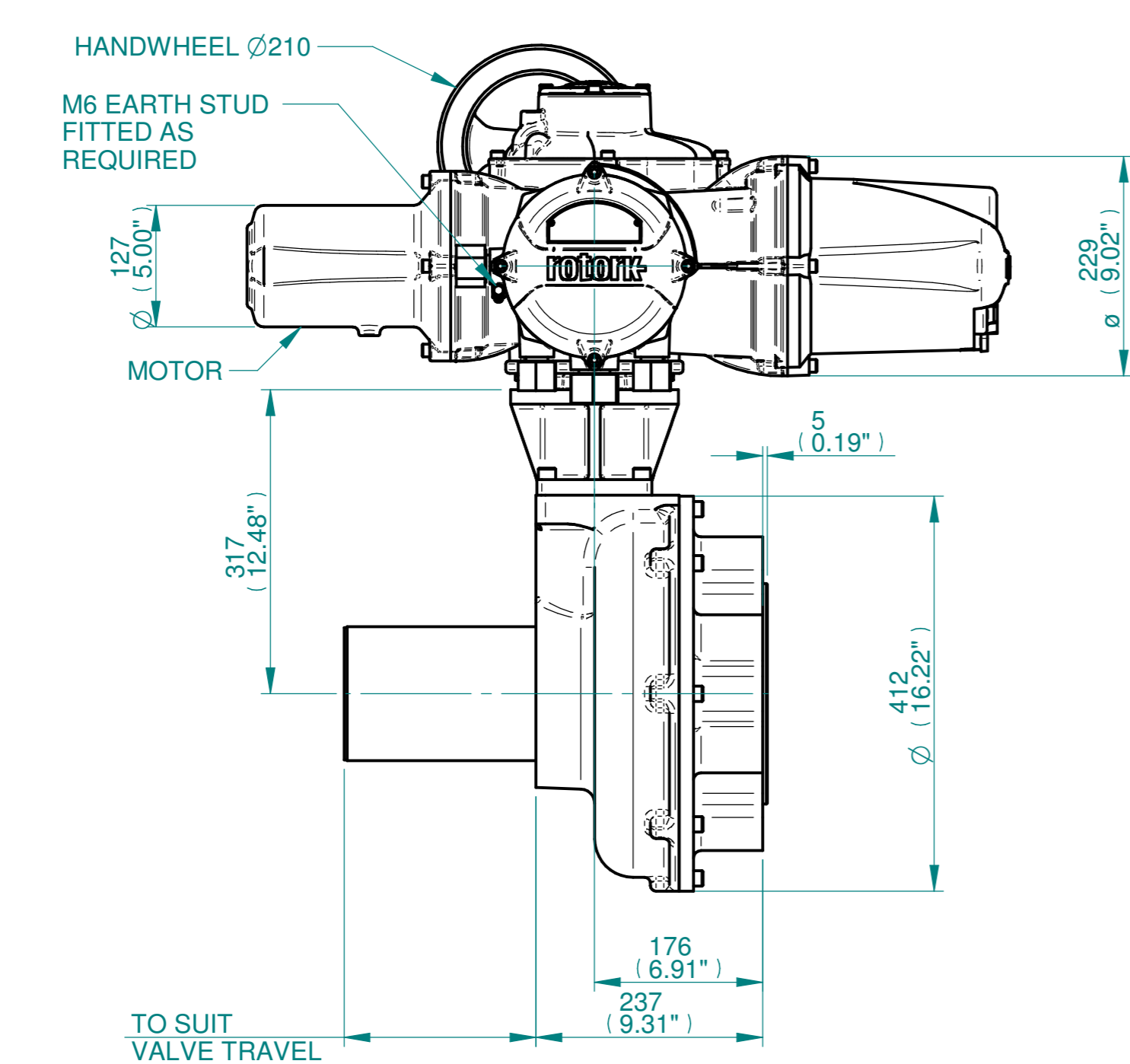

Actuator Size: IQ20/25, IB11, F30/F35/FA30/FA35		Gearbox output flange options								Maximum Bore & Key		
Title IQ20/25, SIDE HANDWHEEL, IB11, F30/F35/FA30/FA35, Ratios 4:1 & 6:1, Installation Details	Designation	F30	F35	-	-	FA30	FA35	-	-	Key form	Ø Bore	Key size
	No. Holes	8	8	-	-	8	8	-	-	Rectangle (BS4235)	96	28 X 16
Drawn JLF Checked NJC Date 11-MAR-15	Hole size	M20	M30	-	-	3/4" UNC	1" UNC	-	-	Rectangle (ANSI B17.1)	3-3/4"	7/8 X 5/8"
Ref SALES Project Ref QUOTATION	PCD	298	356	-	-	11.75"	14"	-	-	Square (ANSI B17.1)	3-1/2"	7/8"

rotork
 www.rotork.com
 Rotork Controls Limited
 Bath, BA1 3JQ, England.
 Telephone 01225-733200

Issue	Description
3	F14 Base change

Scale: 1:6 THIRD ANGLE PROJECTION

Drawing Number	Issue No	Sheet No
I12SHWIB11STD	3	1 of 1

1 2 3 4 5 6 7 8 9 10 11 12