

H
G
F
E
D
C
B
A

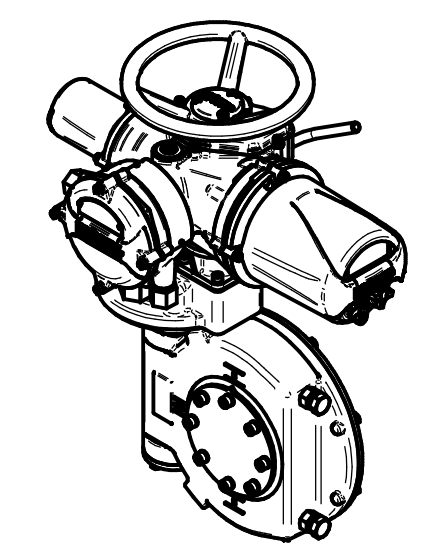
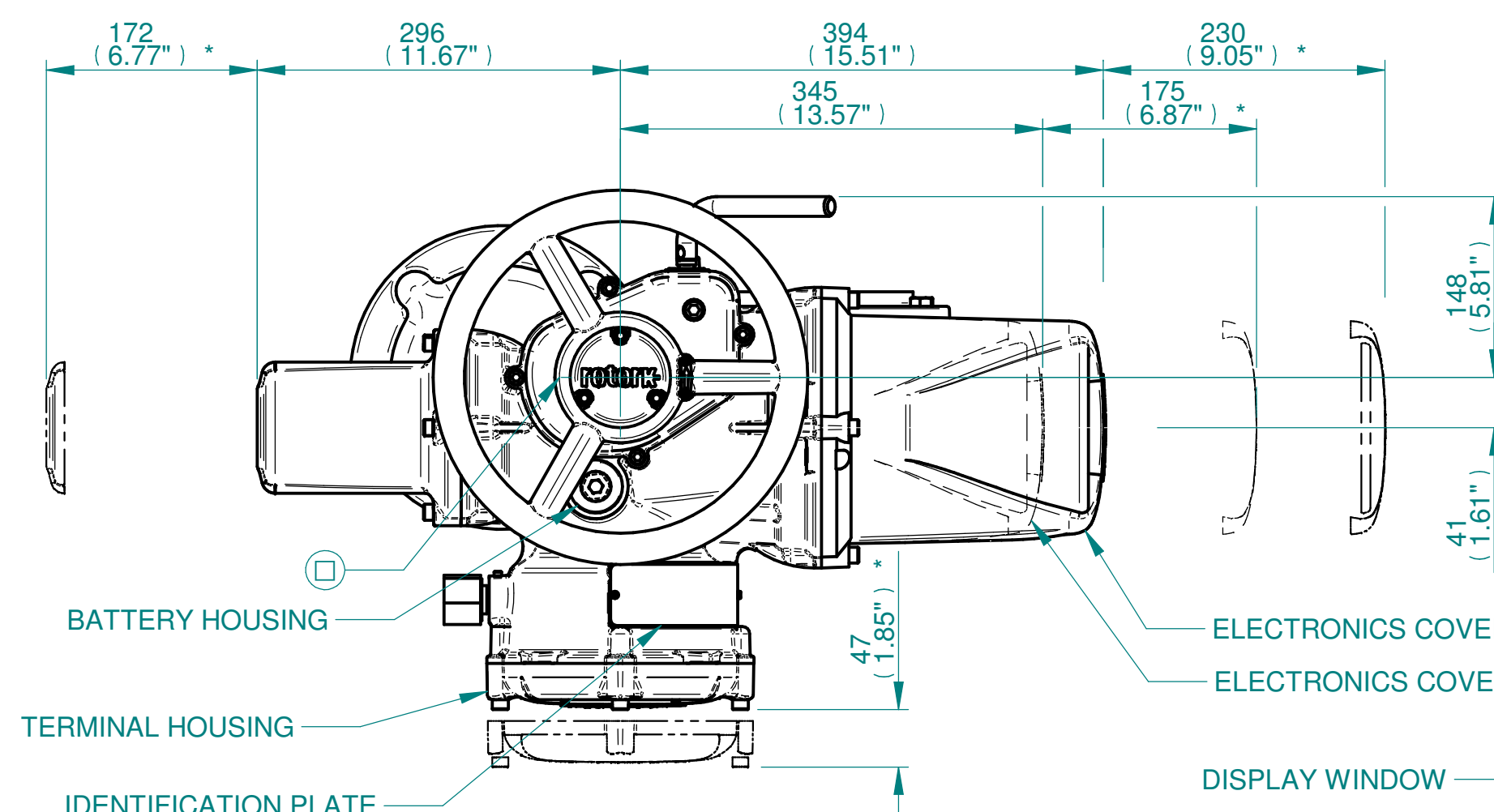

ISOMETRIC VIEW (SCALE 1:12)

NOTES:
 :DIMENSIONS WITH "*" INDICATE COVER REMOVAL ALLOWANCE
 :ELECTRONICS COVER OPTION "****" WILL VARY DEPENDING ON CONFIGURATION
 :NETT WEIGHT = 129kg/284lbs
 : = OIL FILLER/DRAIN PLUG
 :THE INTERFACE PROVIDED FOR MOUNTING THE ACTUATOR OR SECOND STAGE GEARBOX ONTO THE VALVE SHOULD CONFORM TO GOOD ENGINEERING PRACTICES, ENSURING ADEQUATELY TOLERANCED LIMITS FOR PARALLELISM, PERPENDICULARITY AND CONCENTRICITY.
 :ROTORK CANNOT BE HELD LIABLE FOR DAMAGE TO OUR EQUIPMENT CAUSED BY EXCESSIVE LOADING FROM COVER TUBES. (SEE ALSO PUB000-124)

CONDUIT ENTRIES

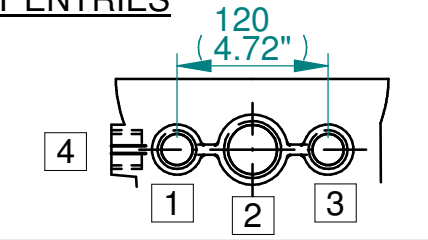

	Hole 1	Hole 2	Hole 3	Hole 4
Size	As Required	As Required	As Required	As Required
Plugged	As Required	As Required	As Required	As Required
Gland	As Required	As Required	As Required	As Required

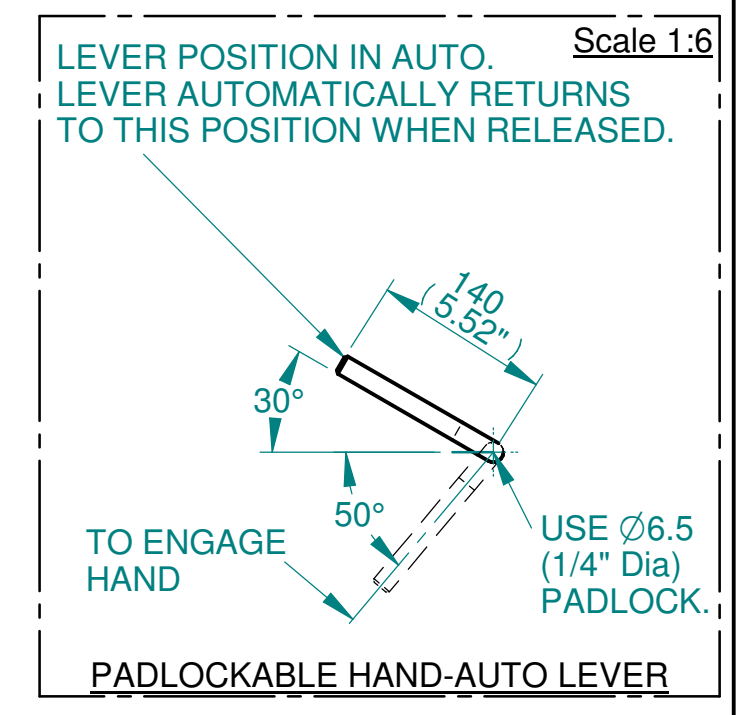
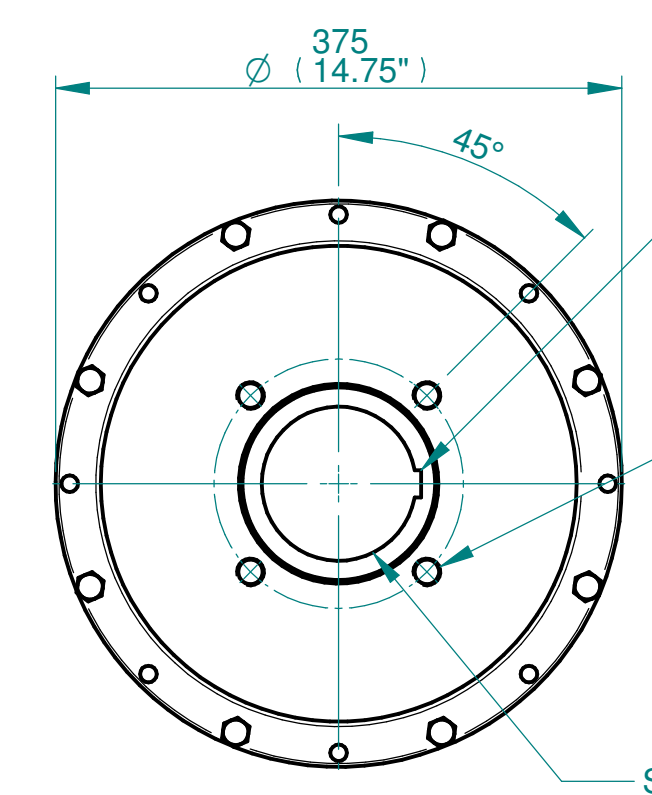
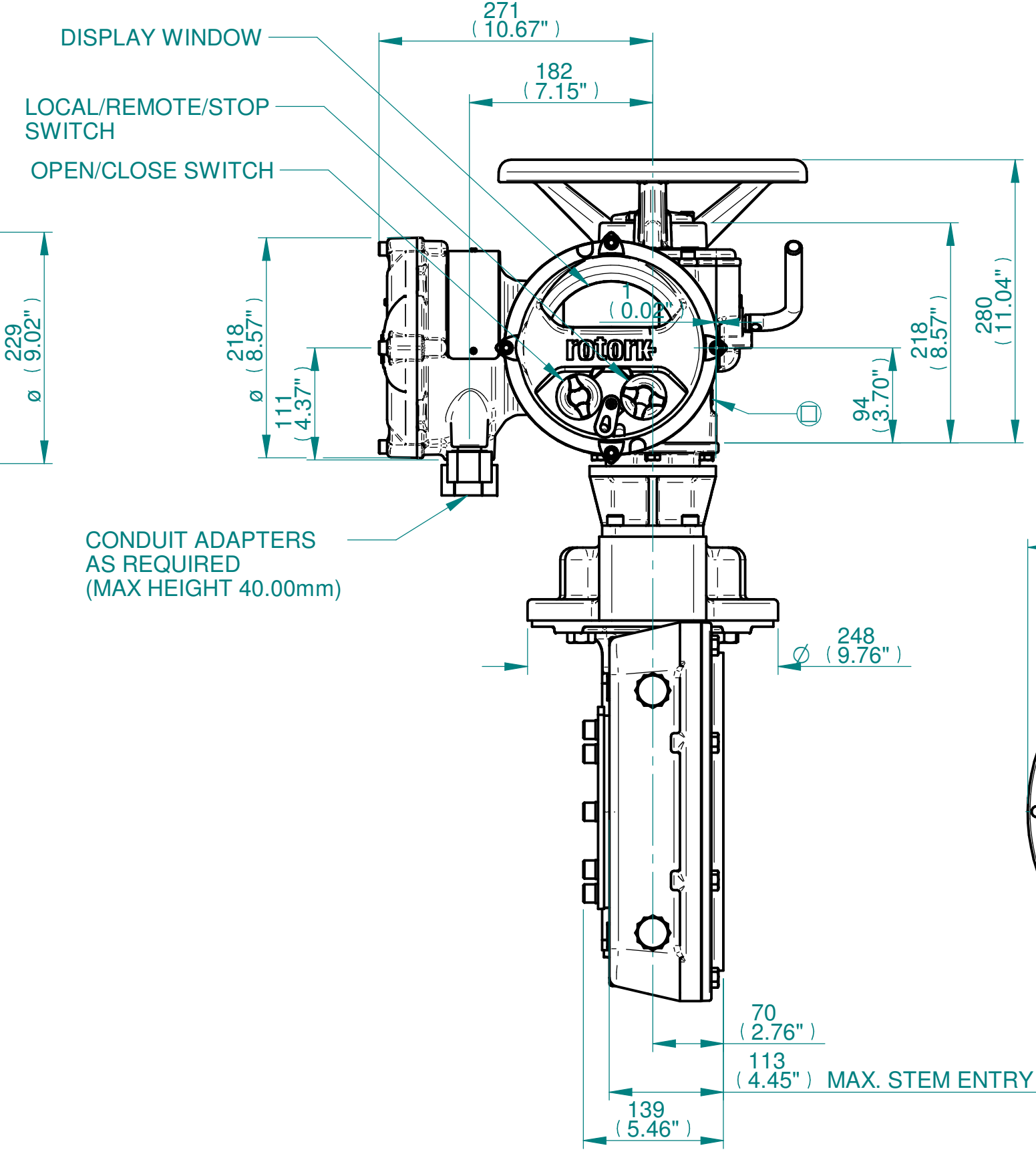
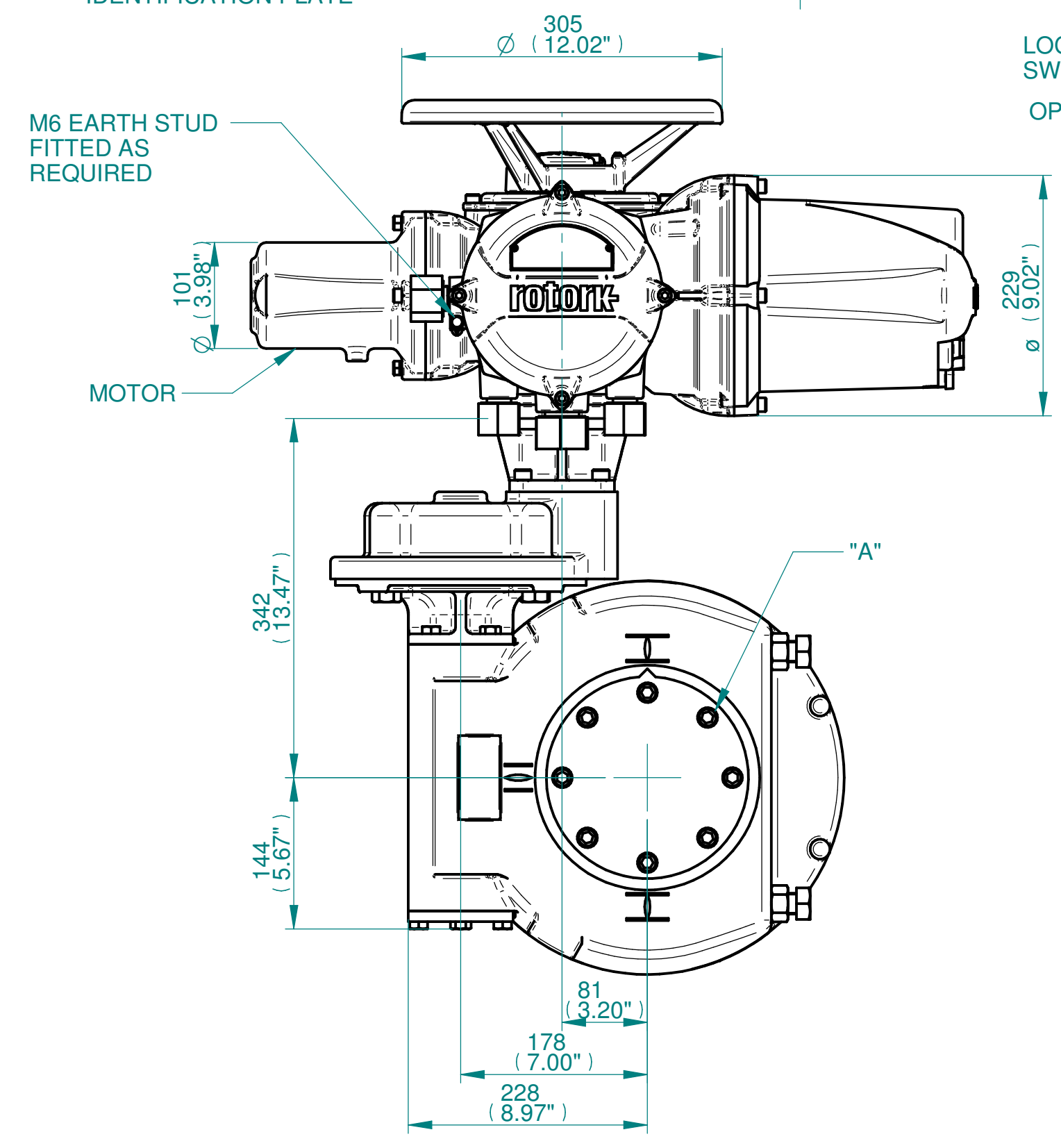

LEVER POSITION IN AUTO. LEVER AUTOMATICALLY RETURNS TO THIS POSITION WHEN RELEASED.
 TO ENGAGE HAND
 PADLOCKABLE HAND-AUTO LEVER
 N.B. KEYWAY POS. CAN BE MOVED IN 45° STEPS BY REMOVING 8 SCREWS MARKED "A" AND ROTATING OUTPUT SLEEVE
 SEE GEARBOX OUTPUT FLANGE OPTIONS TABLE
 SEE MAXIMUM BORE & KEY TABLE

3D Models are available in various formats under the same drawing number



Actuator Size: IQ10/12/18, IW6,62,63 & 66RH/MOW6RH		Gearbox output flange options								Maximum Bore & Key			
Title	IQ10/12/18, TOP HANDWHEEL, IW6RH / IW62RH / IW63RH / IW66RH / MOW6RH, F/FA 16 & 25, Ratios 350 - 456:1 Installation Details	Designation	F16	F25	-	-	FA16	FA25	-	-	Key form	Ø Bore	Key size
Drawn	NJC	No. Holes	4	8	-	-	4	8	-	-	Rectangle (BS4235)	102	28 X 16
Checked	PMJ	Hole size	M20	M16	-	-	3/4" UNC	5/8" UNC	-	-	Rectangle (ANSI B17.1)	3-7/8"	1 X 3/4"
Date	15-MAY-15	PCD	165	254	-	-	6.5"	10"	-	-	Square (ANSI B17.1)	3-3/4"	7/8" SQ
Ref	SALES	Project Ref	QUOTATION										

Issue	Description
3	OUTPUT FLANGE CHANGE

Scale: 1:5 THIRD ANGLE PROJECTION

Drawing Number	Issue No	Sheet No
I11THWIW6RHSTD	3	1 of 1

1 2 3 4 5 6 7 8 9 10 11 12