

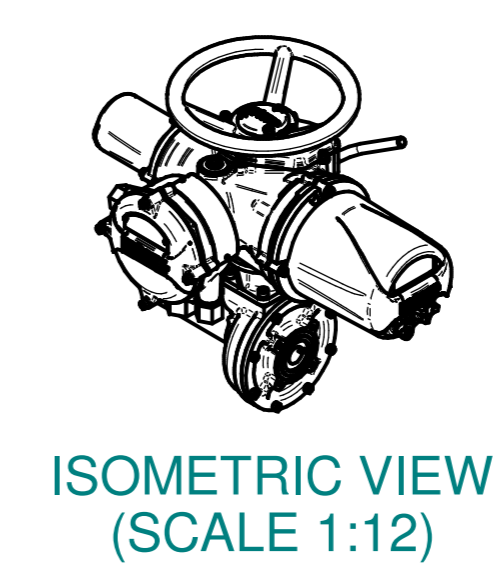

H  
G  
F  
E  
D  
C  
B  
A

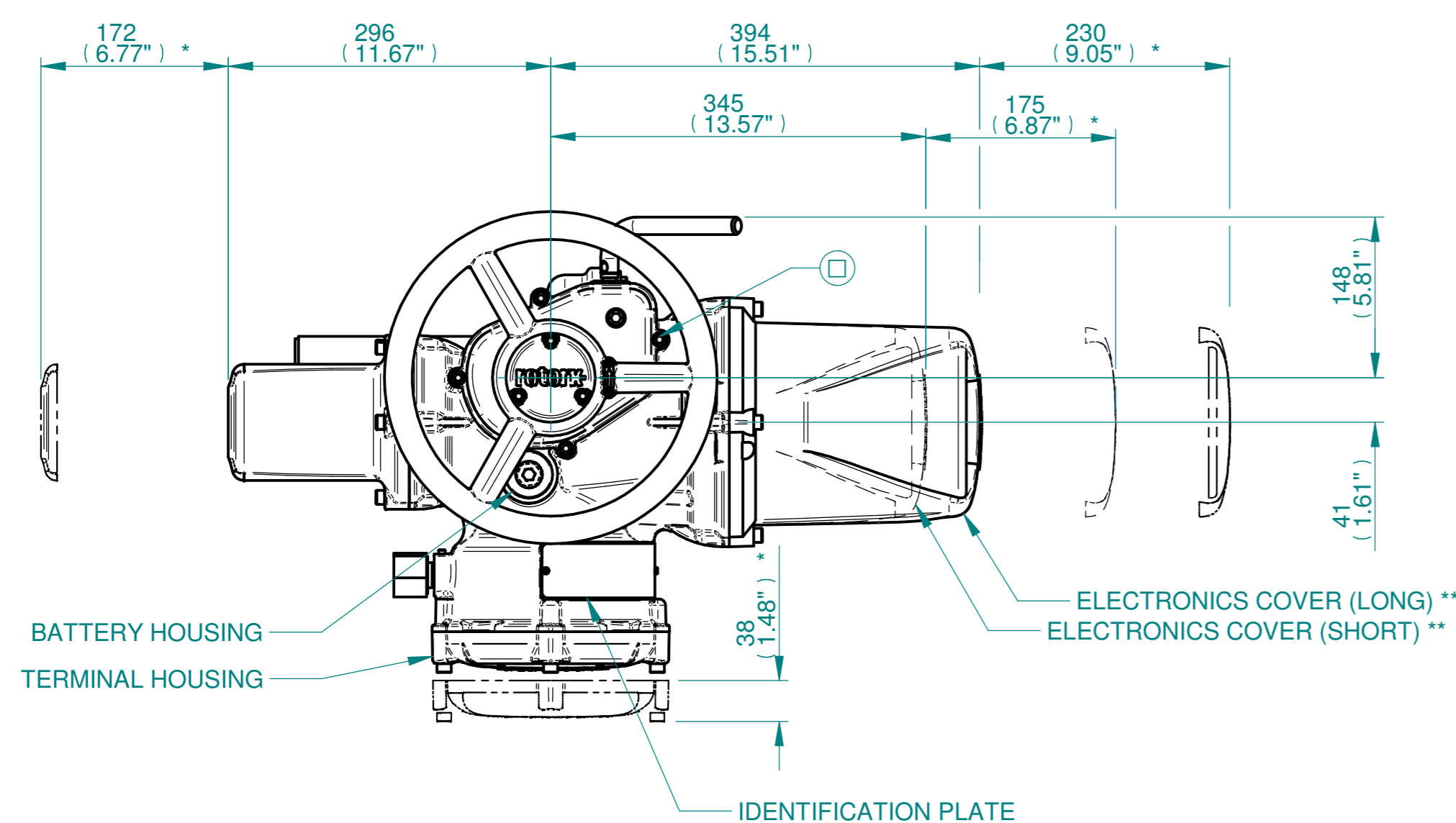

**NOTES:**  
 :DIMENSIONS WITH \*\*\* INDICATE COVER REMOVAL ALLOWANCE  
 :ELECTRONICS COVER OPTION \*\*\*\*\* WILL VARY DEPENDING ON CONFIGURATION  
 :NETT WEIGHT = 47kg/103lbs  
 :  = OIL FILLER/DRAIN PLUG  
 :THE INTERFACE PROVIDED FOR MOUNTING THE ACTUATOR OR SECOND STAGE GEARBOX ONTO THE VALVE SHOULD CONFORM TO GOOD ENGINEERING PRACTICES, ENSURING ADEQUATELY TOLERANCED LIMITS FOR PARALLELISM, PERPENDICULARITY AND CONCENTRICITY.  
 :ROTORCK CANNOT BE HELD LIABLE FOR DAMAGE TO OUR EQUIPMENT CAUSED BY EXCESSIVE LOADING FROM COVER TUBES. (SEE ALSO PUB000-124)

**CONDUIT ENTRIES**

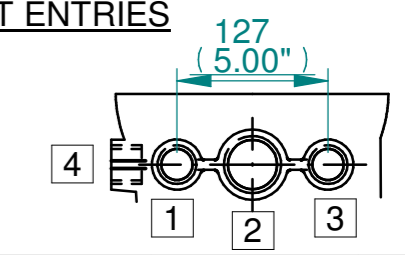

	Hole 1	Hole 2	Hole 3	Hole 4
Size	As Required	As Required	As Required	As Required
Plugged	As Required	As Required	As Required	As Required
Gland	As Required	As Required	As Required	As Required

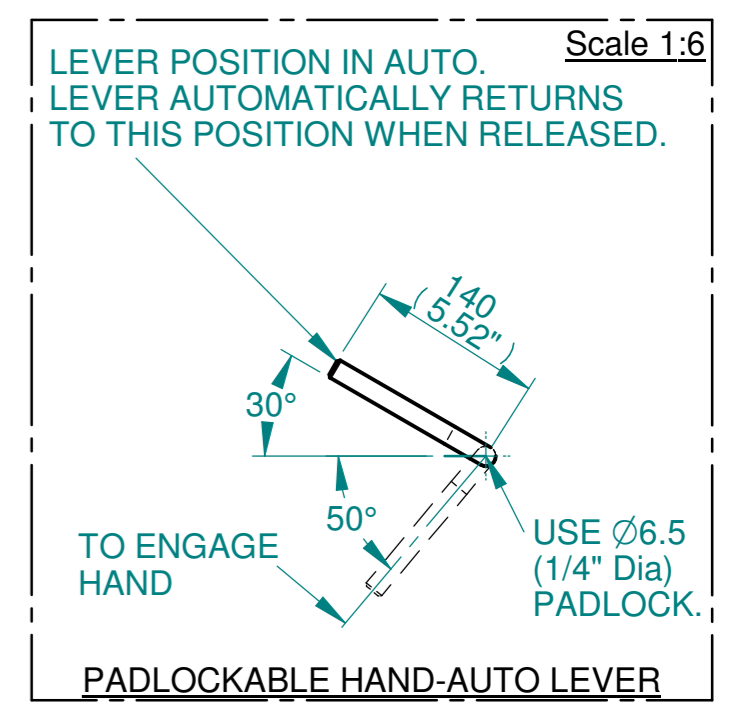
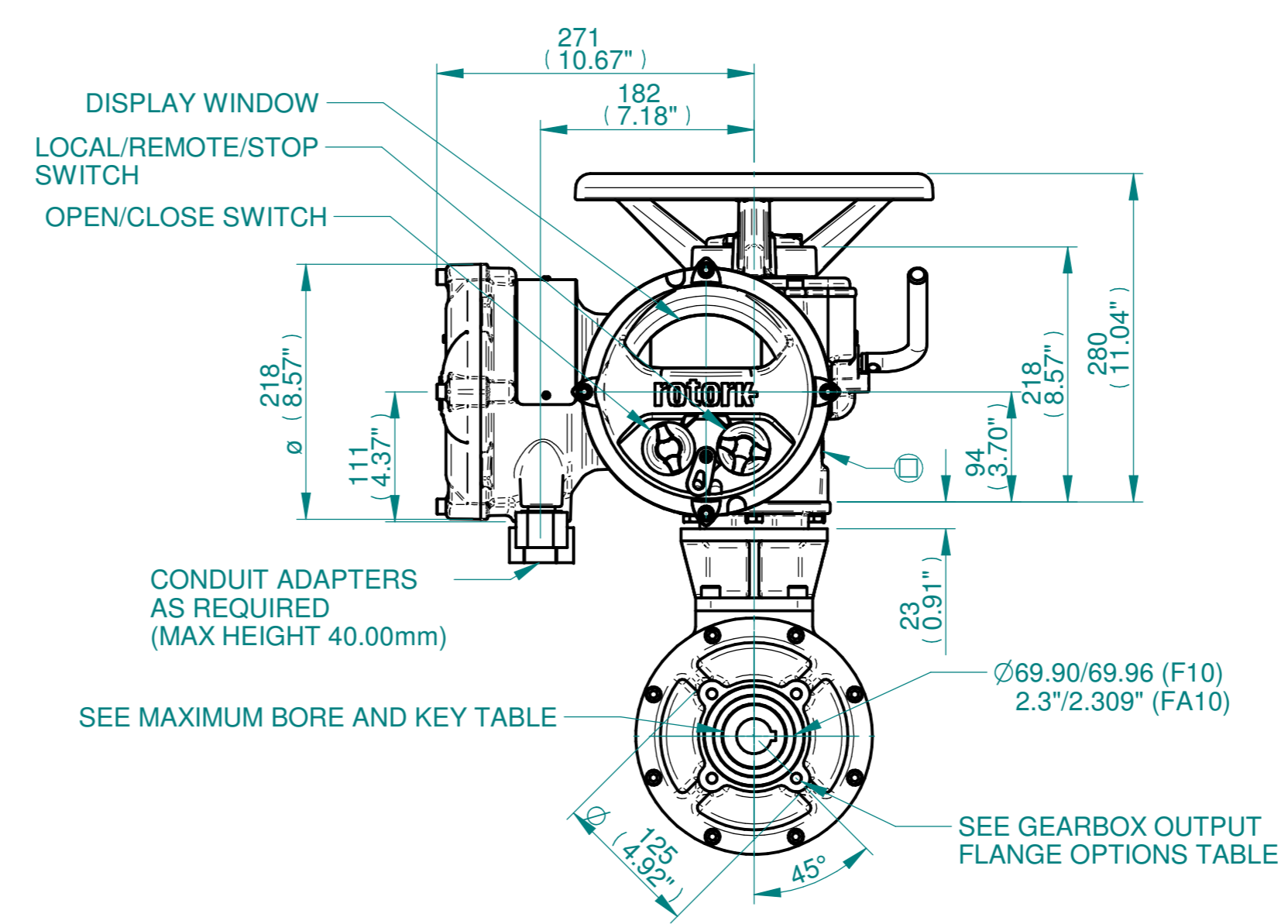
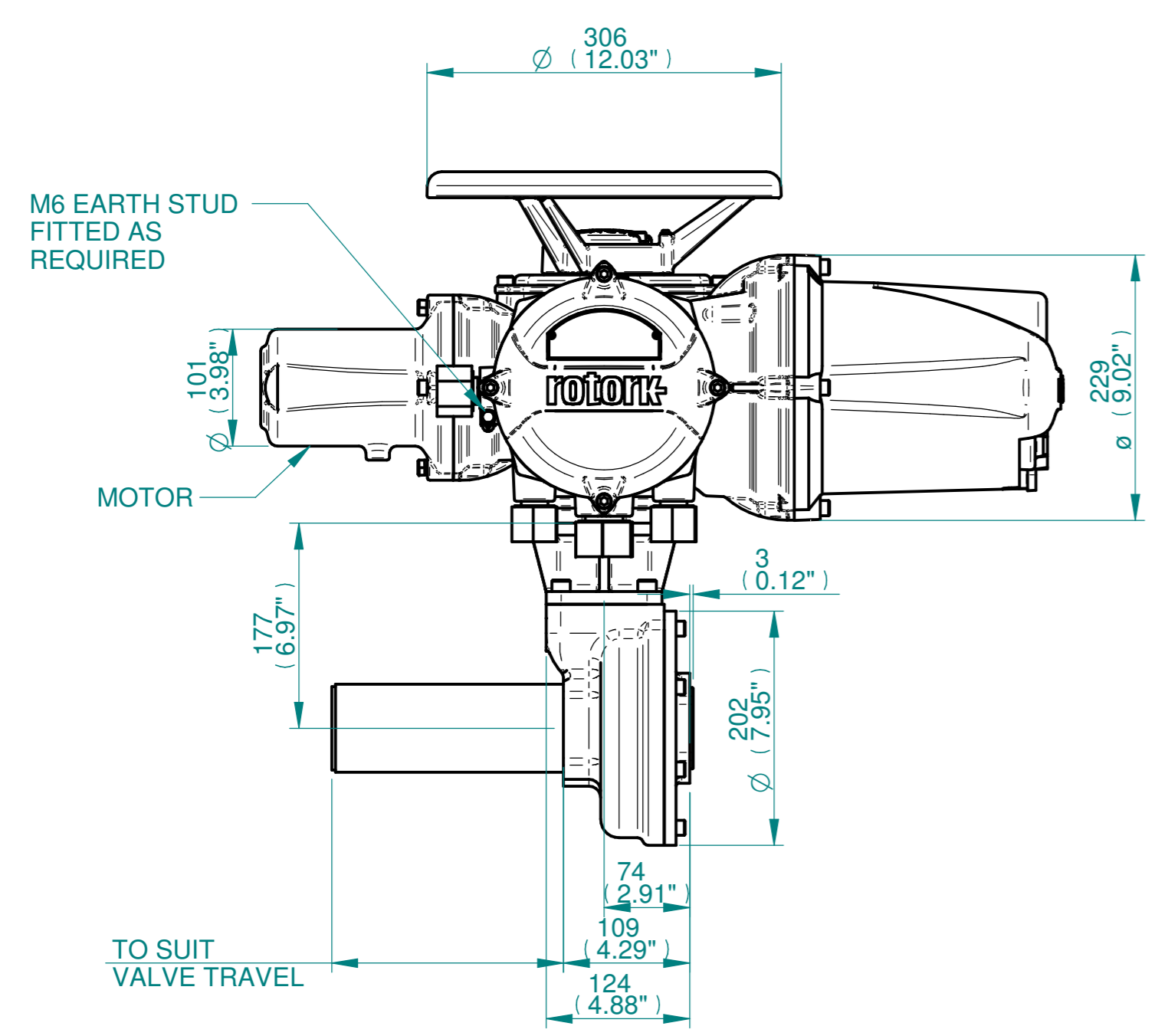

Actuator Size: IQ10/12/18, IB4, F10/FA10		Gearbox output flange options								Maximum Bore & Key			
Title	IQ10/12/18, TOP HANDWHEEL, IB4, F10/FA10, Ratios 2:1,3:1,4:1 & 6:1 Installation Details	Designation	F10	-	-	-	FA10	-	-	-	Key form	Ø Bore	Key size
Drawn	JLF	Checked	NJC	Date	11-MAR-15	No. Holes	4	-	-	-	Rectangle (BS4235)	40	12 X 8
Ref	SALES	Project Ref	QUOTATION	Hole size	M10	-	-	-	3/8" UNC	-	Rectangle (ANSI B17.1)	1-5/8"	3/8 X 1/4"
				PCD	102	-	-	-	4"	-	Square (ANSI B17.1)	1-1/2"	3/8"

Issue	Description
2	4 ENTRY CHANGE

Scale: 1:5  THIRD ANGLE PROJECTION

Drawing Number	Issue No	Sheet No
I11THWIB4STD	2	1 of 1

1 2 3 4 5 6 7 8 9 10 11 12