

H
G
F
E
D
C
B
A

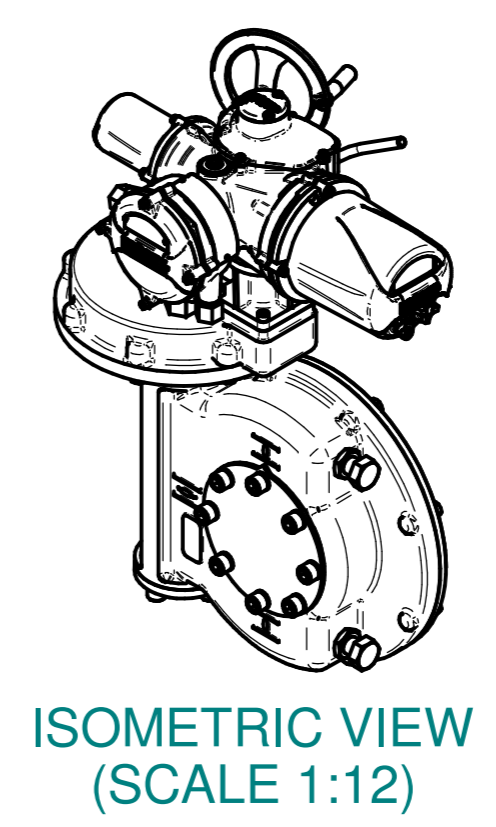

NOTES:
 :DIMENSIONS WITH "*" INDICATE COVER REMOVAL ALLOWANCE
 :ELECTRONICS COVER OPTION "****" WILL VARY DEPENDING ON CONFIGURATION
 :NETT WEIGHT = 303kg/668lbs
 : = OIL FILLER/DRAIN PLUG
 :THE INTERFACE PROVIDED FOR MOUNTING THE ACTUATOR OR SECOND STAGE GEARBOX ONTO THE VALVE SHOULD CONFORM TO GOOD ENGINEERING PRACTICES, ENSURING ADEQUATELY TOLERANCED LIMITS FOR PARALLELISM, PERPENDICULARITY AND CONCENTRICITY.
 :ROTORK CANNOT BE HELD LIABLE FOR DAMAGE TO OUR EQUIPMENT CAUSED BY EXCESSIVE LOADING FROM COVER TUBES. (SEE ALSO PUB000-124)

CONDUIT ENTRIES

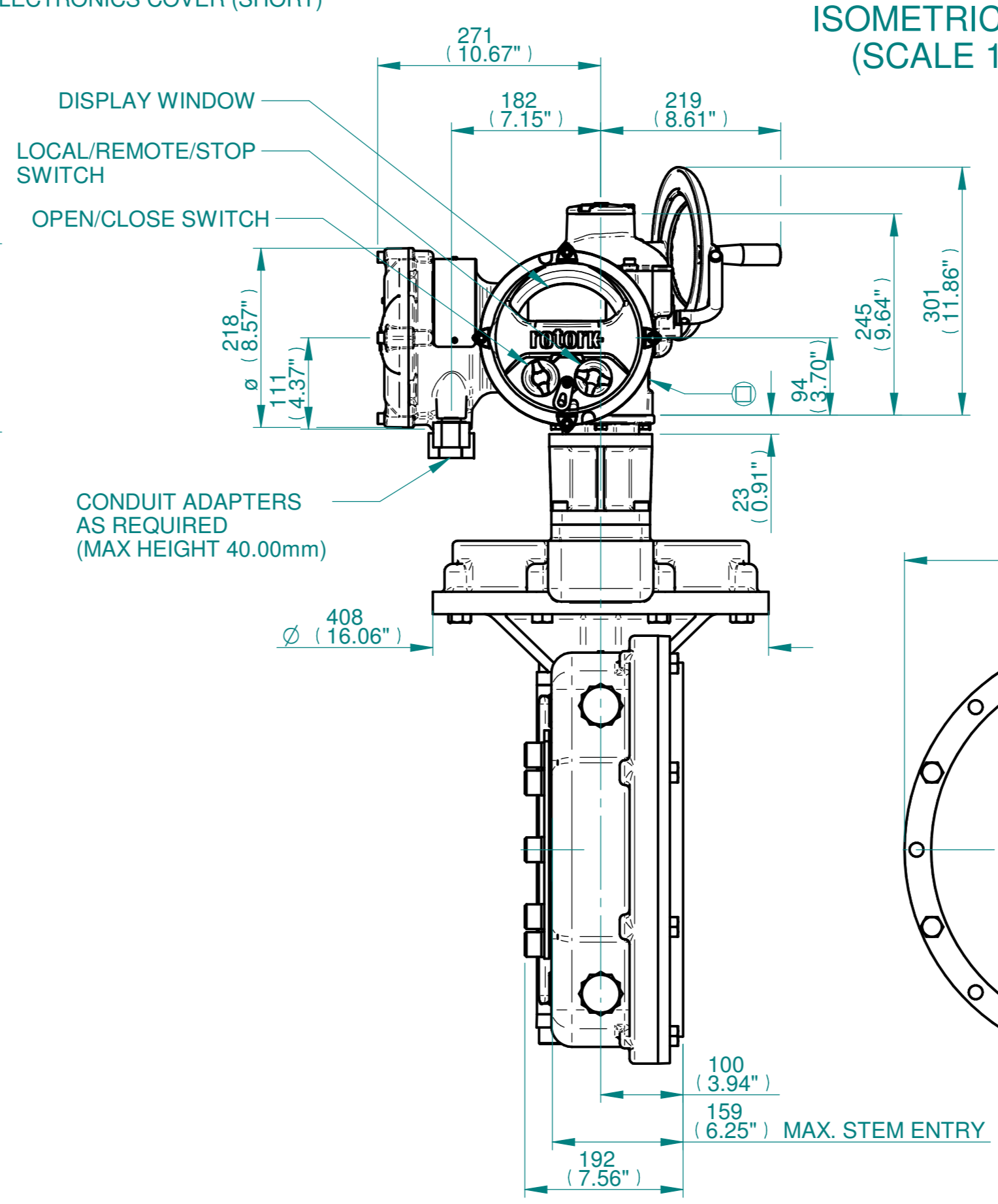
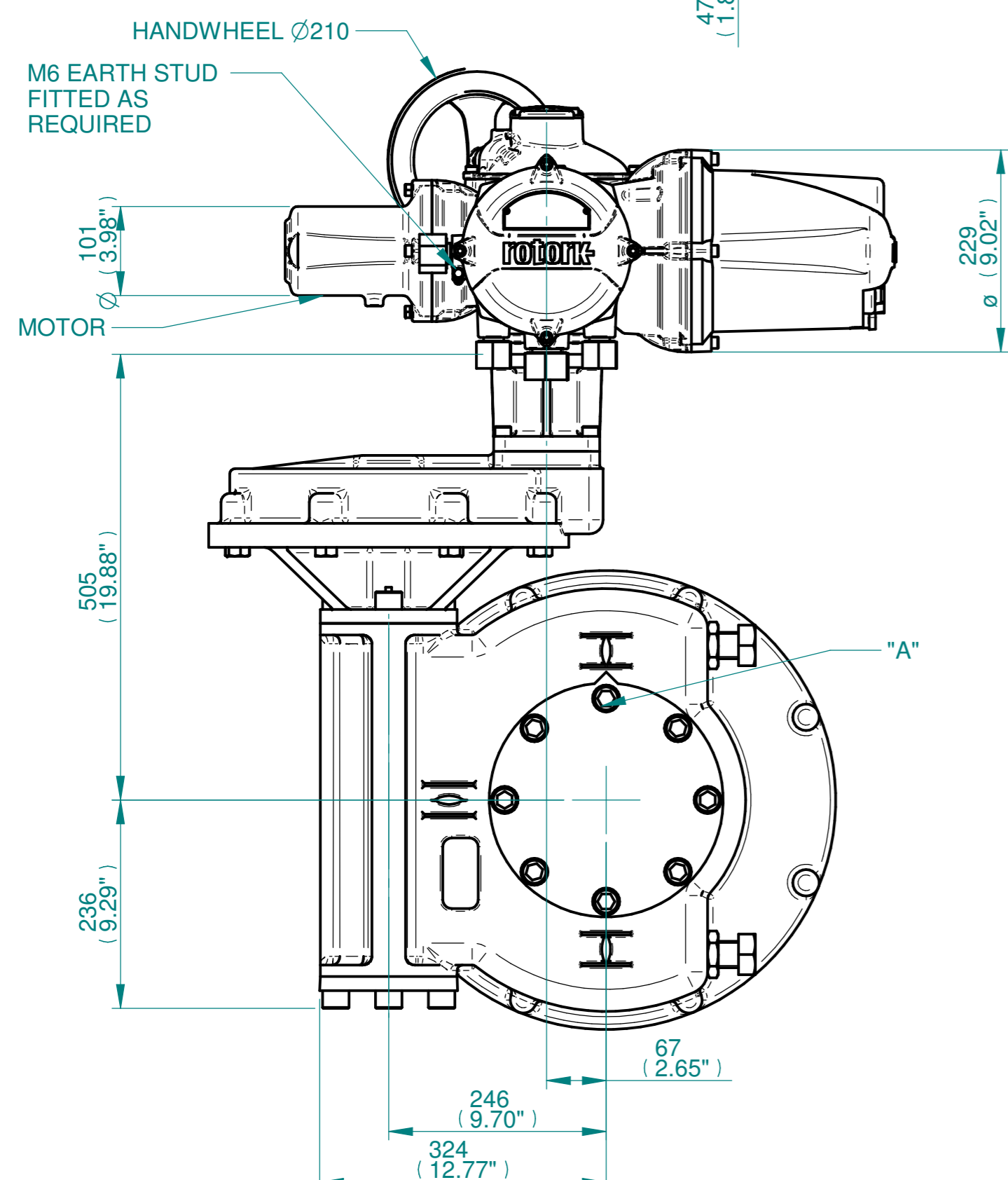
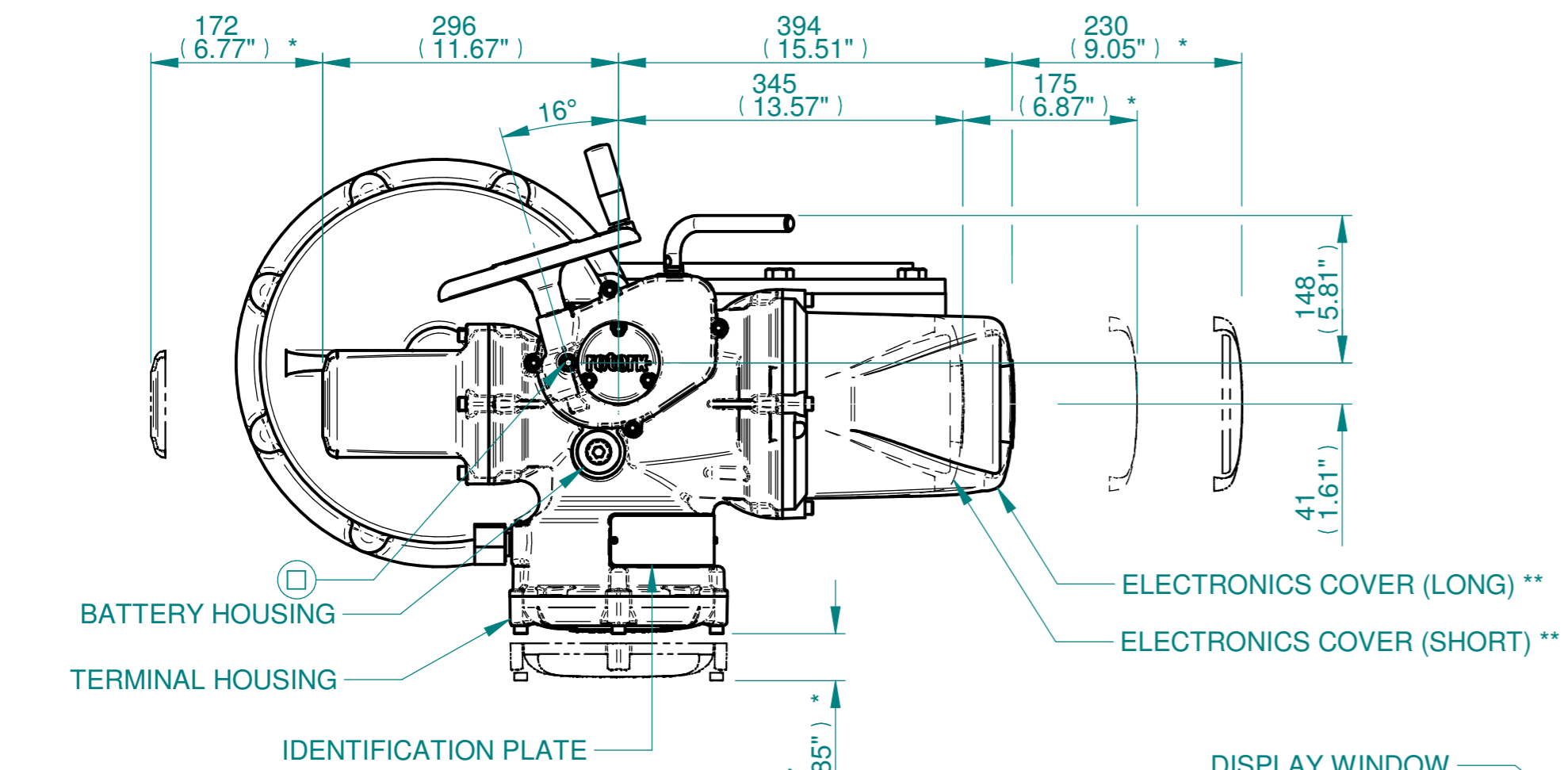
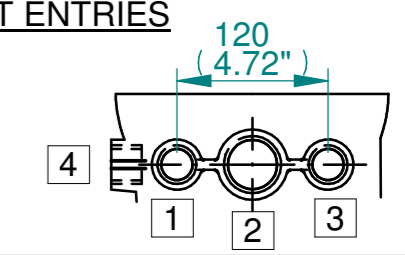

	Hole 1	Hole 2	Hole 3	Hole 4
Size	As Required	As Required	As Required	As Required
Plugged	As Required	As Required	As Required	As Required
Gland	As Required	As Required	As Required	As Required

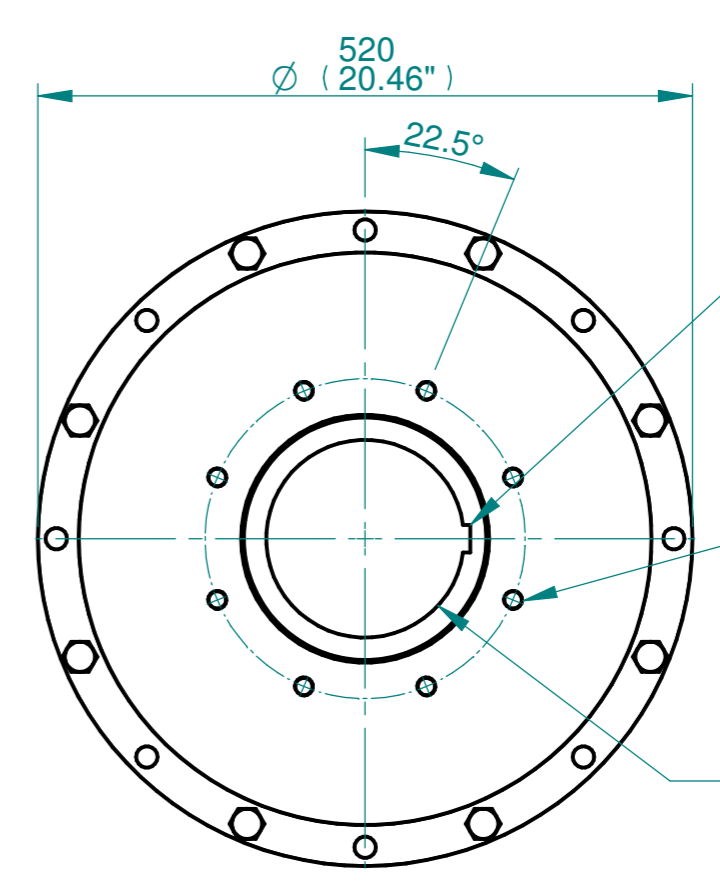
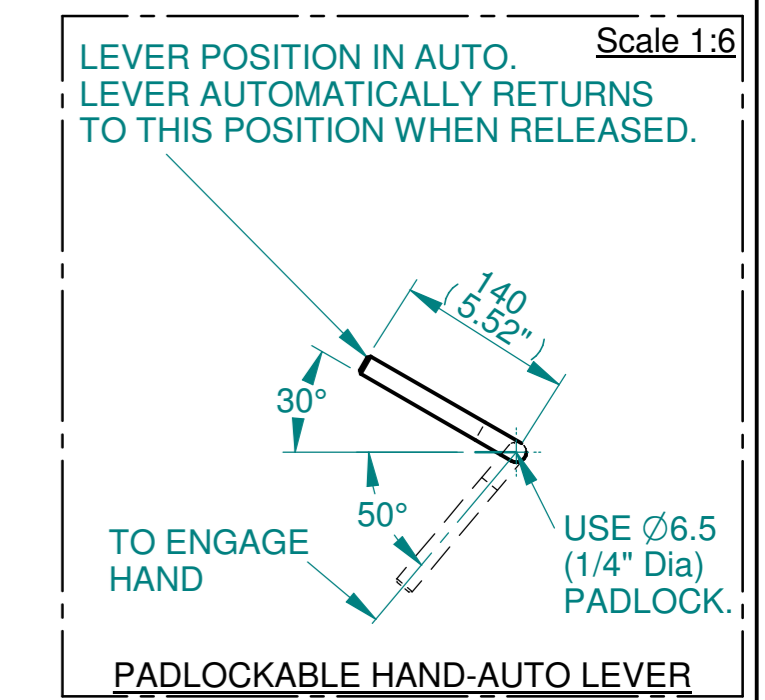

3D Models are available in various formats under the same drawing number

rotork
 www.rotork.com
 Rotork Controls Limited
 Bath, BA1 3JQ, England.
 Telephone 01225-733200

Actuator Size: IQ10/12/18 IW8,82 & 86RH/MOW8RH		Gearbox output flange options								Maximum Bore & Key			
Title	IQ10/12/18, SIDE HANDWHEEL, IW8RH / IW82RH / IW86RH / MOW8RH, F/FA25, 30,35 & 40, Ratios 480 - 768:1 Installation Details	Designation	F25	F30	F35	F40	FA25	FA30	FA35	FA40	Key form	Ø Bore	Key size
Drawn	TED	No. Holes	8	8	8	8	8	8	8	8	Rectangle (BS4235)	157	40 X 22
Checked	NJC	Hole size	M16	M20	M30	M36	5/8" UNC	3/4" UNC	1" UNC	1-1/4" UNC	Rectangle (ANSI B17.1)	6"	1-1/2 X 1"
Date	18-AUG-14	PCD	254	298	356	406	10"	11-3/4"	14"	16"	Square (ANSI B17.1)	5-5/8"	1-1/2" SQ
Ref	SALES	Project Ref	QUOTATION										

Issue	Description
3	OUTPUT FLANGE CHANGE
Scale: 1:6	THIRD ANGLE PROJECTION
A2	Drawing Number Issue No Sheet No
11	111SHWIW8RHSTD 3 1 of 1

1 2 3 4 5 6 7 8 9 10 11 12