

H  
G  
F  
E  
D  
C  
B  
A

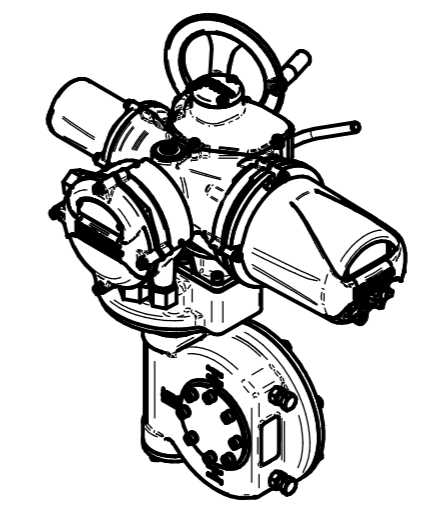
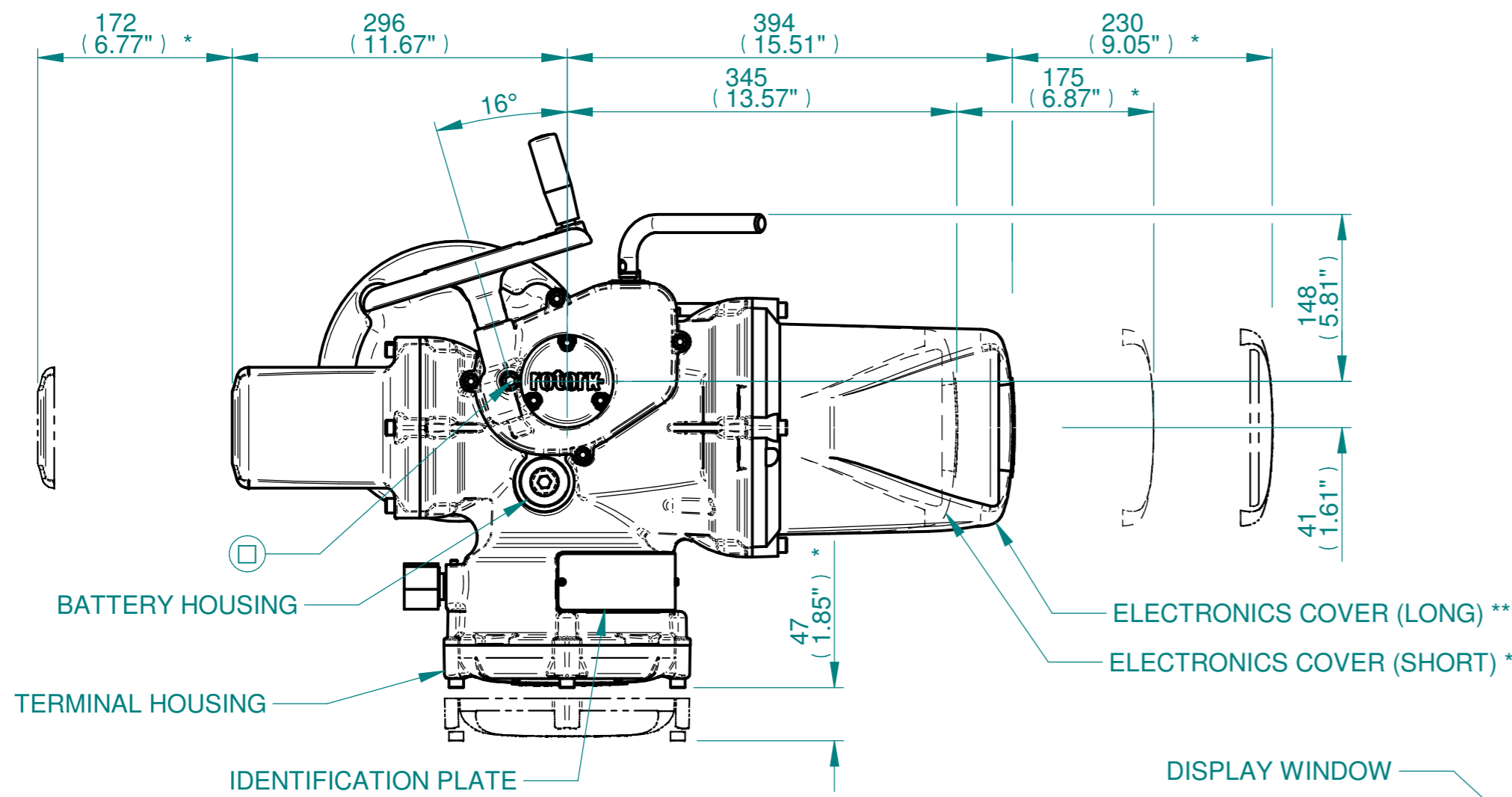

ISOMETRIC VIEW  
(SCALE 1:12)

**NOTES:**  
 :DIMENSIONS WITH \*\*\* INDICATE COVER REMOVAL ALLOWANCE  
 :ELECTRONICS COVER OPTION \*\*\*\* WILL VARY DEPENDING ON CONFIGURATION  
 :NETT WEIGHT = 98kg/216lbs  
 : = OIL FILLER/DRAIN PLUG  
 :THE INTERFACE PROVIDED FOR MOUNTING THE ACTUATOR OR SECOND STAGE GEARBOX ONTO THE VALVE SHOULD CONFORM TO GOOD ENGINEERING PRACTICES, ENSURING ADEQUATELY TOLERANCED LIMITS FOR PARALLELISM, PERPENDICULARITY AND CONCENTRICITY.  
 :ROTORK CANNOT BE HELD LIABLE FOR DAMAGE TO OUR EQUIPMENT CAUSED BY EXCESSIVE LOADING FROM COVER TUBES. (SEE ALSO E156E)

**CONDUIT ENTRIES**

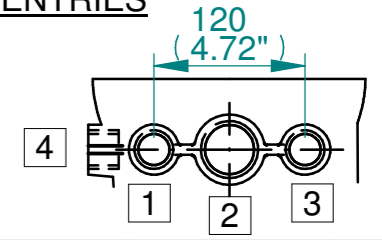

	Hole 1	Hole 2	Hole 3	Hole 4
Size	As Required	As Required	As Required	As Required
Plugged	As Required	As Required	As Required	As Required
Gland	As Required	As Required	As Required	As Required

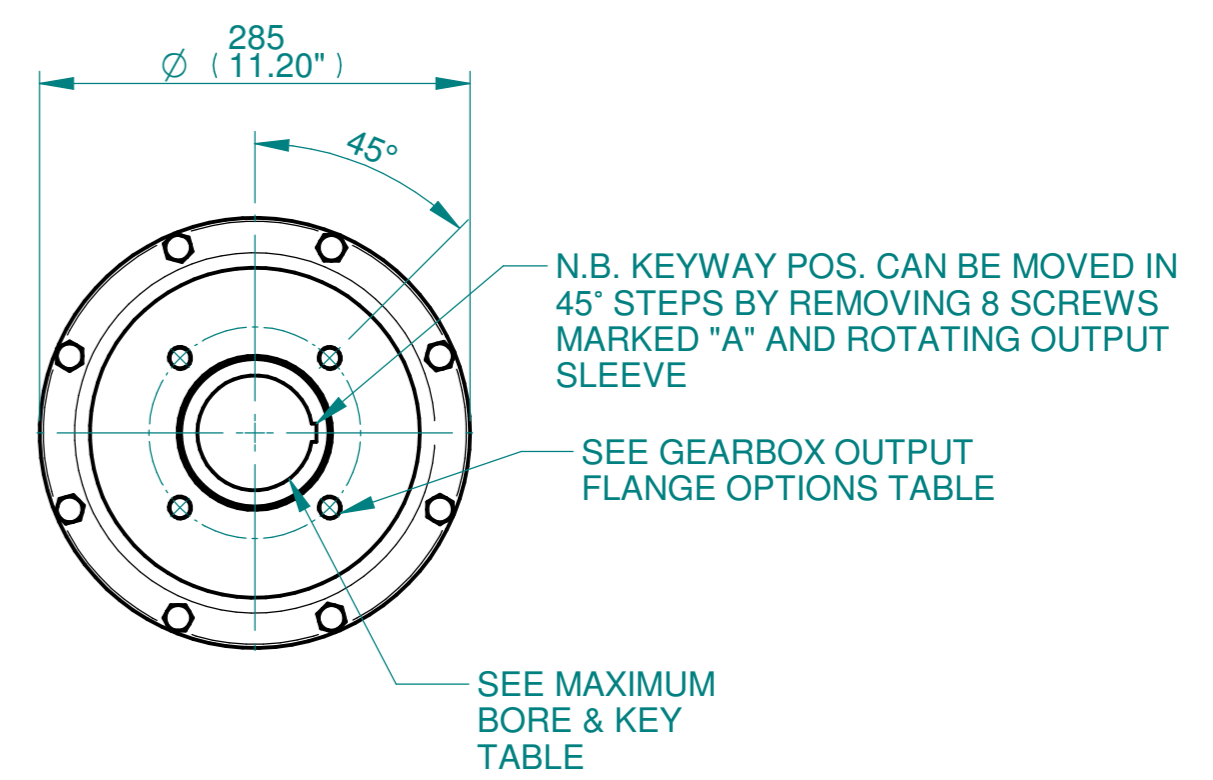
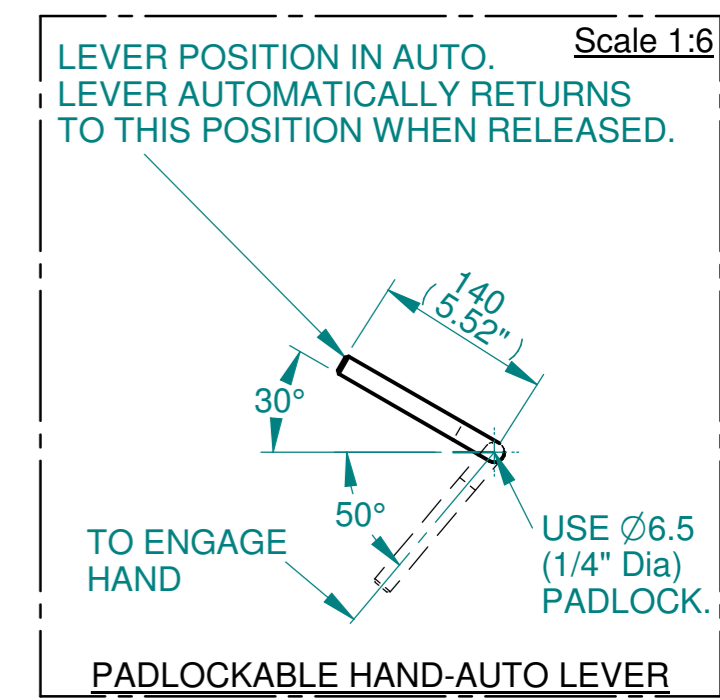
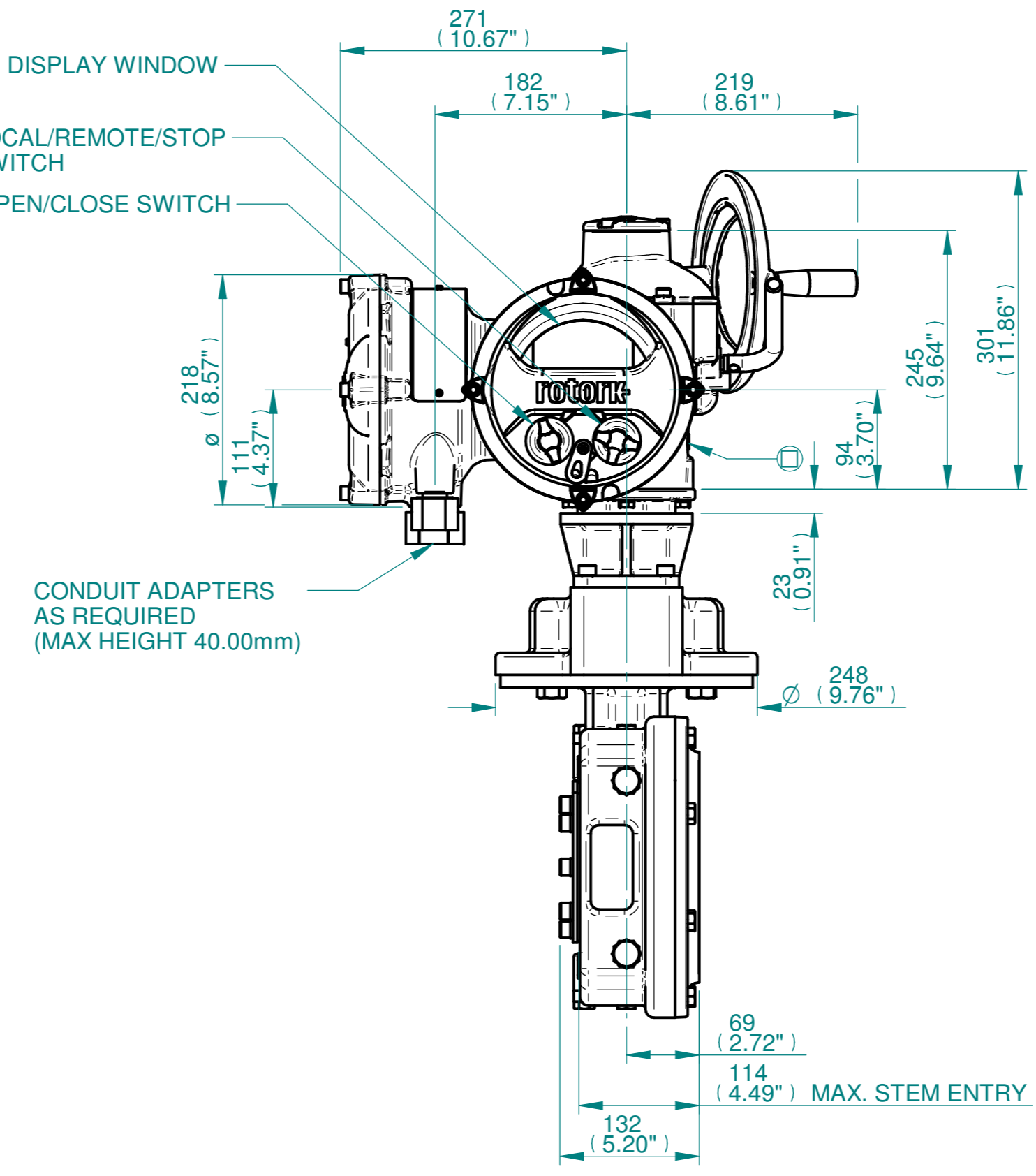
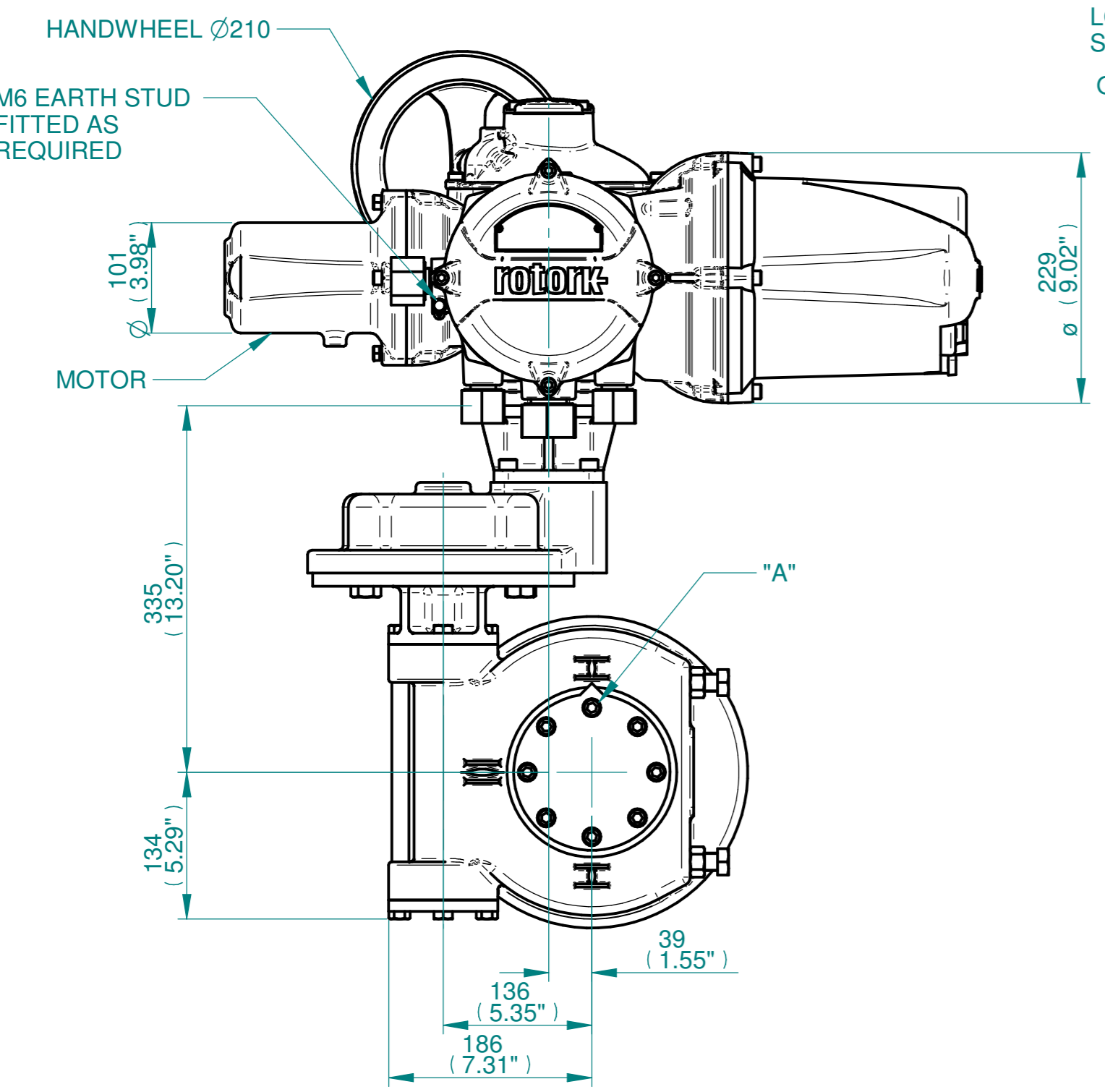

3D Models are available in various formats under the same drawing number



Rotork Controls Limited  
 Bath, BA1 3JQ, England.  
 Telephone 01225-733200

Actuator Size: IQ10/12/18 IW5,52 & 56RH/MOW5RH		Gearbox output flange options								Maximum Bore & Key			
Title	IQ10/12/18, SIDE HANDWHEEL, IW5RH / MOW5RH / IW52RH / IW56RH, F/FA 14 & 16, Ratios 200 - 420:1 Installation Details	Designation	F14	F16	-	-	FA14	FA16	-	-	Key form	Ø Bore	Key size
Drawn	TED	No. Holes	4	4	-	-	4	4	-	-	Rectangle (BS4235)	76	22 x 14
Checked	NJC	Hole size	M16	M20	-	-	5/8" UNC	3/4" UNC	-	-	Rectangle (ANSI B17.1)	3"	3/4 x 1/2"
Date	18-AUG-14	PCD	140	165	-	-	5.5"	6.5"	-	-	Square (ANSI B17.1)	2-3/4"	5/8"SQ
Ref	SALES	Project Ref	QUOTATION										

Issue	Description
3	OUTPUT FLANGE CHANGE
Scale: 1:5	
THIRD ANGLE PROJECTION	
A2	Drawing Number Issue No Sheet No
111SHWIW5RHSTD	3 1 of 1

1 2 3 4 5 6 7 8 9 10 11 12