

NOTES:
 :DIMENSIONS WITH "*" INDICATE COVER REMOVAL ALLOWANCE
 :ELECTRONICS COVER OPTION "****" WILL VARY DEPENDING ON CONFIGURATION
 :NETT WEIGHT = 106kg/234lbs
 :  = OIL FILLER/DRAIN PLUG
 :THE INTERFACE PROVIDED FOR MOUNTING THE ACTUATOR OR SECOND STAGE GEARBOX ONTO THE VALVE SHOULD CONFORM TO GOOD ENGINEERING PRACTICES, ENSURING ADEQUATELY TOLERANCED LIMITS FOR PARALLELISM, PERPENDICULARITY AND CONCENTRICITY.
 :ROTORK CANNOT BE HELD LIABLE FOR DAMAGE TO OUR EQUIPMENT CAUSED BY EXCESSIVE LOADING FROM COVER TUBES. (SEE ALSO PUB000-124)

CONDUIT ENTRIES

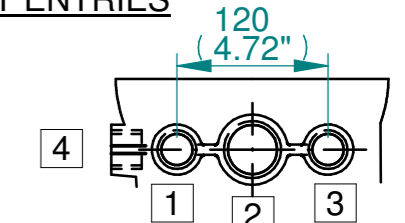

	Hole 1	Hole 2	Hole 3	Hole 4
Size	As Required	As Required	As Required	As Required
Plugged	As Required	As Required	As Required	As Required
Gland	As Required	As Required	As Required	As Required

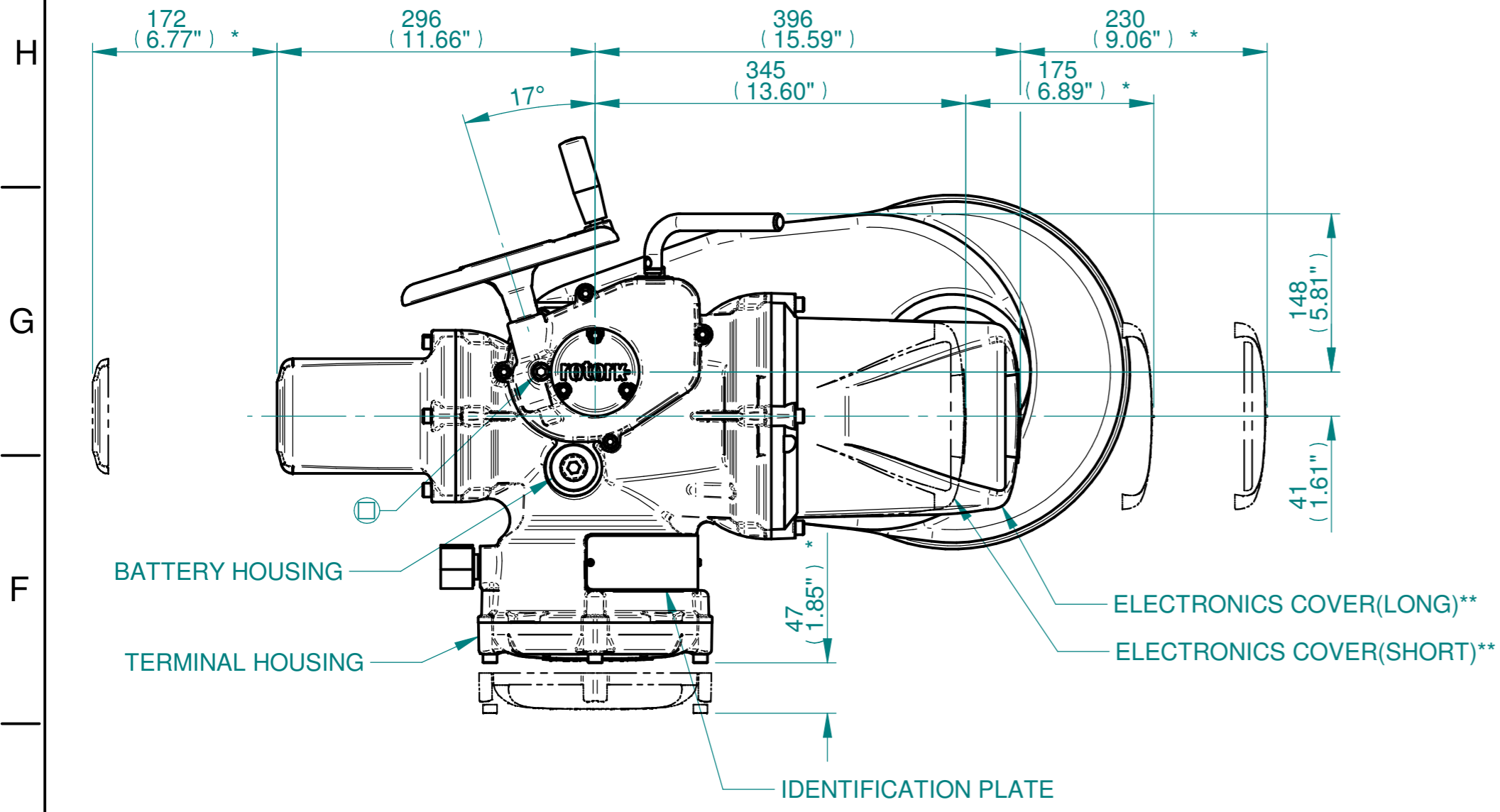

ISOMETRIC VIEW 1:10

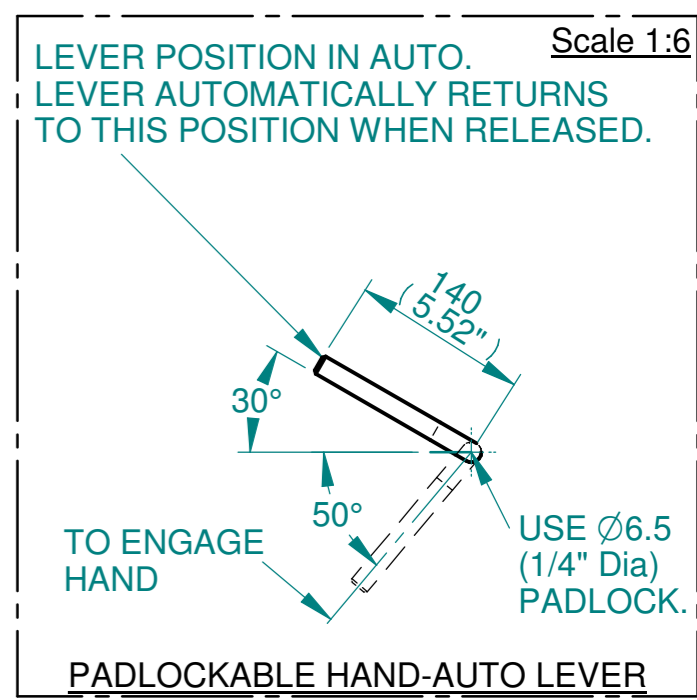
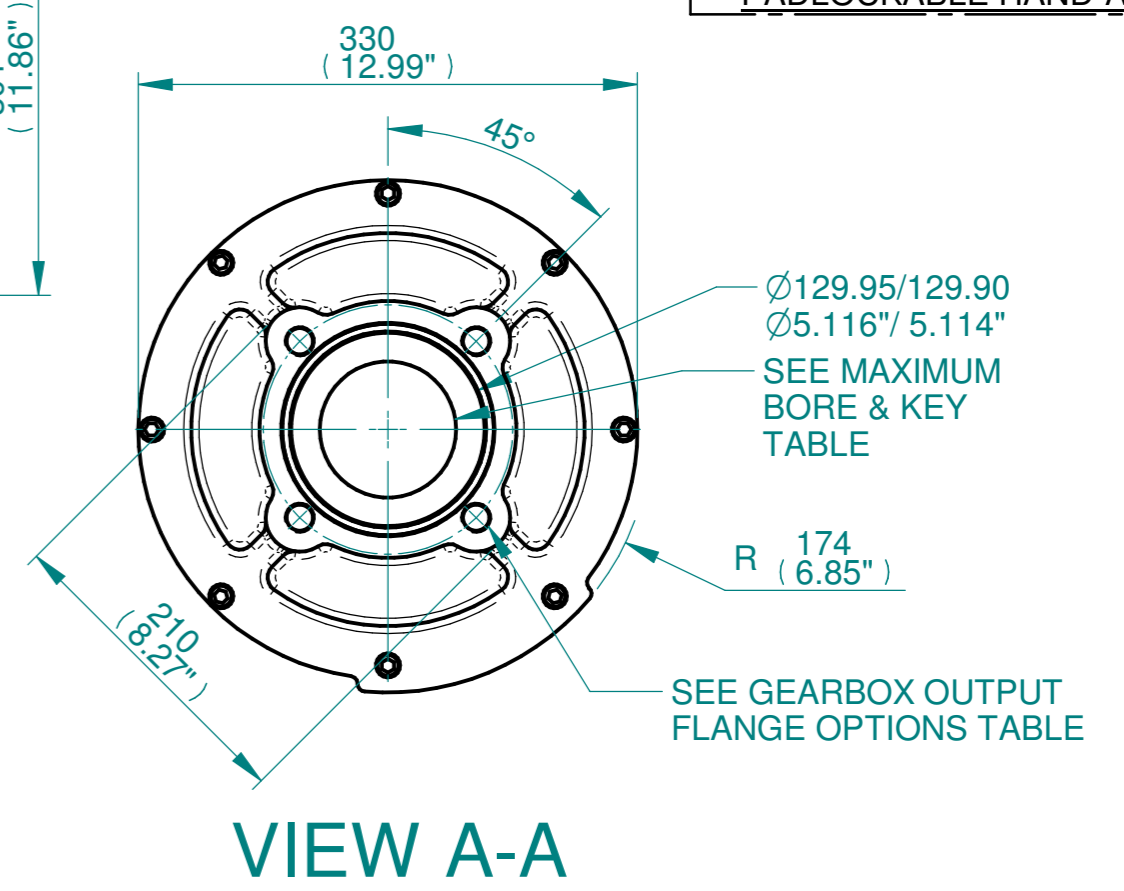
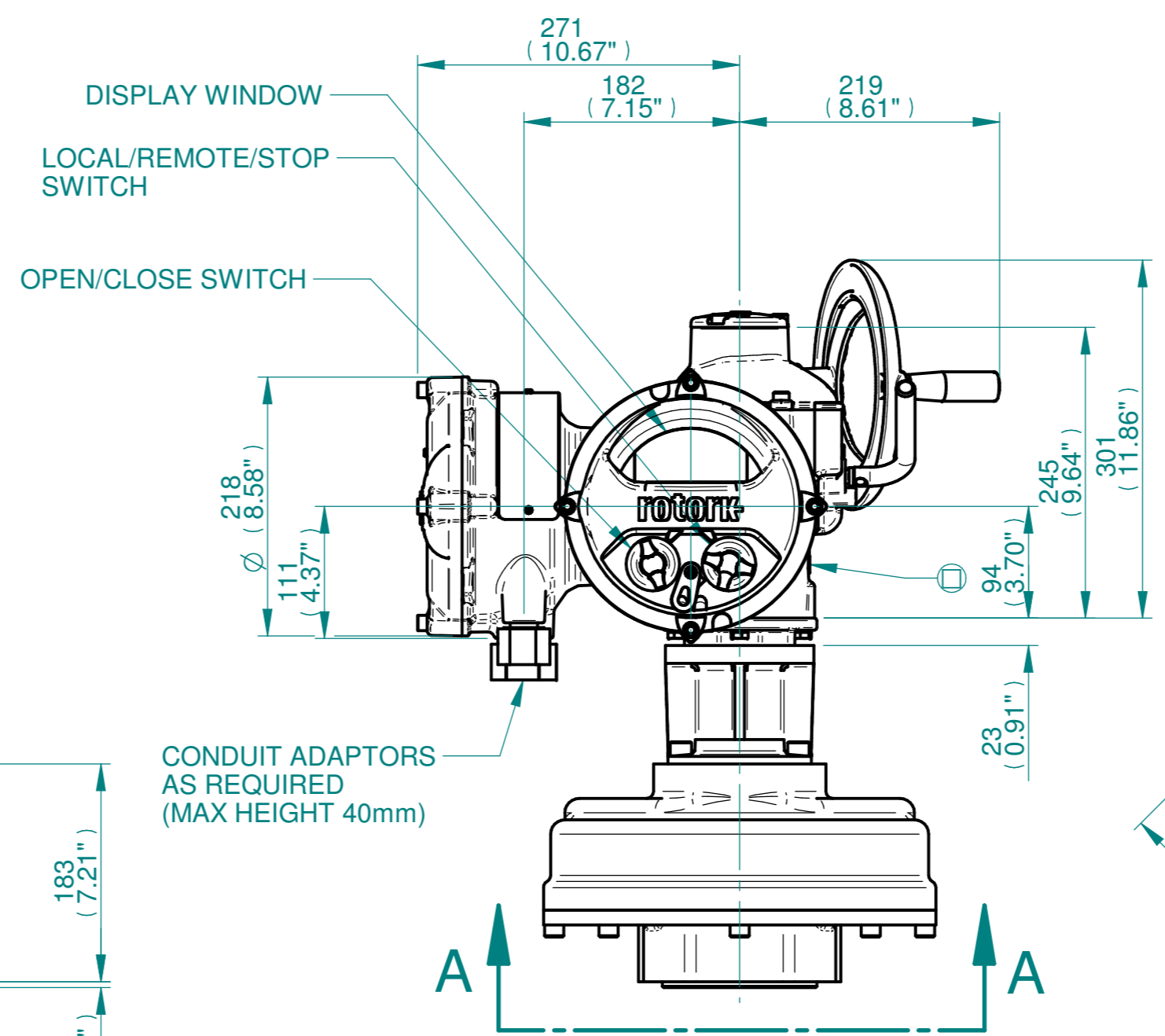
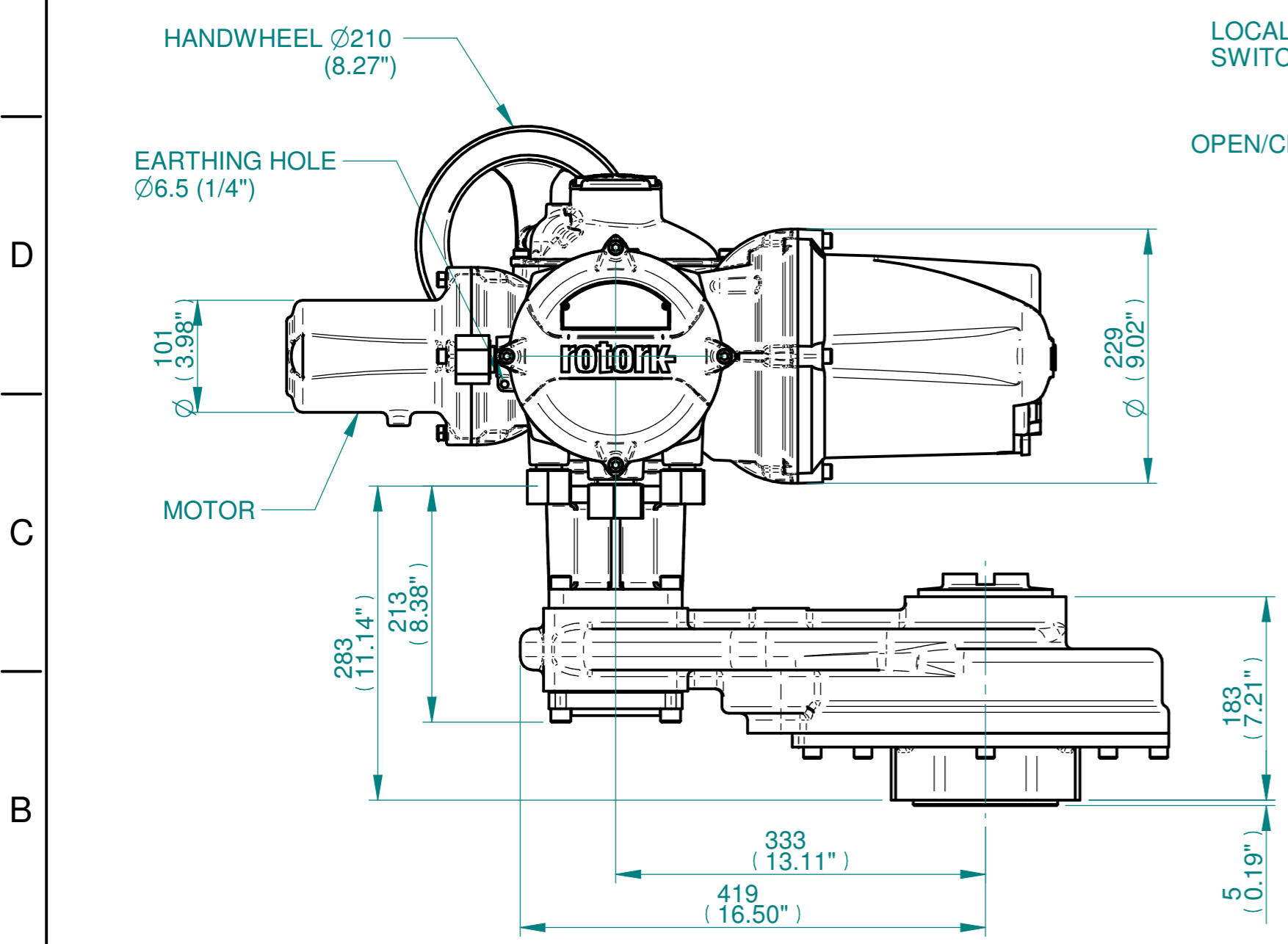
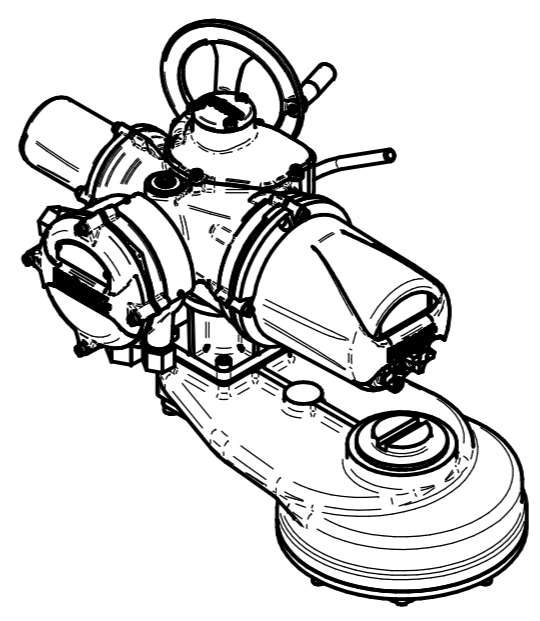

rotork
 www.rotork.com
 Rotork Controls Limited
 Bath, BA1 3JQ, England.
 Telephone 01225-733200

Actuator Size: IQ10/12/18, IS8		Gearbox output flange options								Maximum Bore & Key			
Title	IQ10/12/18, SIDE HANDWHEEL, IS8, F16, FA16, Ratios 4:1,6:1,8:1,10:1,12:1 15:1 Installation Details	Designation	F16	-	-	-	FA16	-	-	-	Key form	Ø Bore	Key size
Drawn	DH	Checked	JBA	Date	JAN 19	No. Holes	4	-	-	-	Rectangle (BS4235)	68	20 x 12
Ref	SALES	Project Ref	QUOTATION	Hole size	M20	-	-	-	3/4" UNC	-	-	-	-
				PCD	165	-	-	-	61/2"	-	-	-	-

3D Models are available in various formats under the same drawing number

Issue	Description
1	FIRST ISSUE

Scale: 1:5  THIRD ANGLE PROJECTION

Drawing Number	Issue No	Sheet No
I11SHWIS8STD	1	1 of 1