

H
G
F
E
D
C
B
A

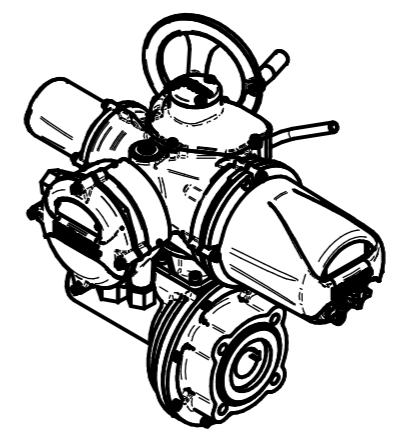
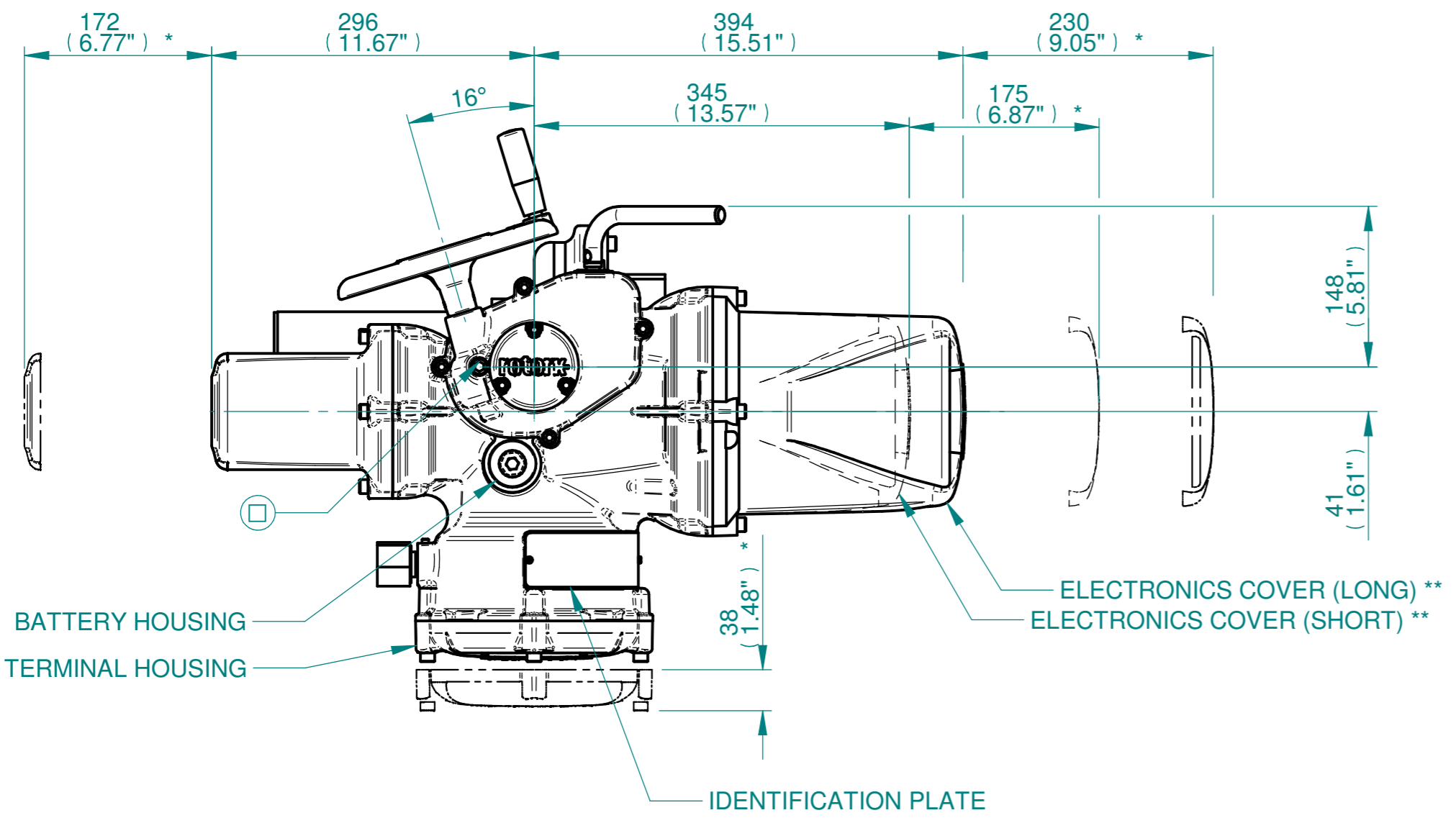

ISOMETRIC VIEW (SCALE 1:12)

NOTES:
 :DIMENSIONS WITH "*" INDICATE COVER REMOVAL ALLOWANCE
 :ELECTRONICS COVER OPTION "****" WILL VARY DEPENDING ON CONFIGURATION
 :NETT WEIGHT = F16:66kg/145lbs, F25:76kg, 167lbs
 : = OIL FILLER/DRAIN PLUG
 :THE INTERFACE PROVIDED FOR MOUNTING THE ACTUATOR OR SECOND STAGE GEARBOX ONTO THE VALVE SHOULD CONFORM TO GOOD ENGINEERING PRACTICES, ENSURING ADEQUATELY TOLERANCED LIMITS FOR PARALLELISM, PERPENDICULARITY AND CONCENTRICITY.
 :ROTORK CANNOT BE HELD LIABLE FOR DAMAGE TO OUR EQUIPMENT CAUSED BY EXCESSIVE LOADING FROM COVER TUBES. (SEE ALSO PUB000-124)

CONDUIT ENTRIES

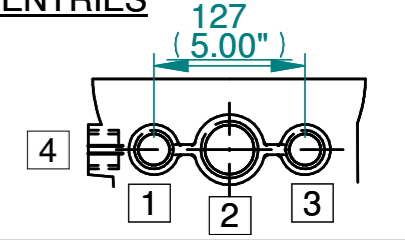

	Hole 1	Hole 2	Hole 3	Hole 4
Size	As Required	As Required	As Required	As Required
Plugged	As Required	As Required	As Required	As Required
Gland	As Required	As Required	As Required	As Required

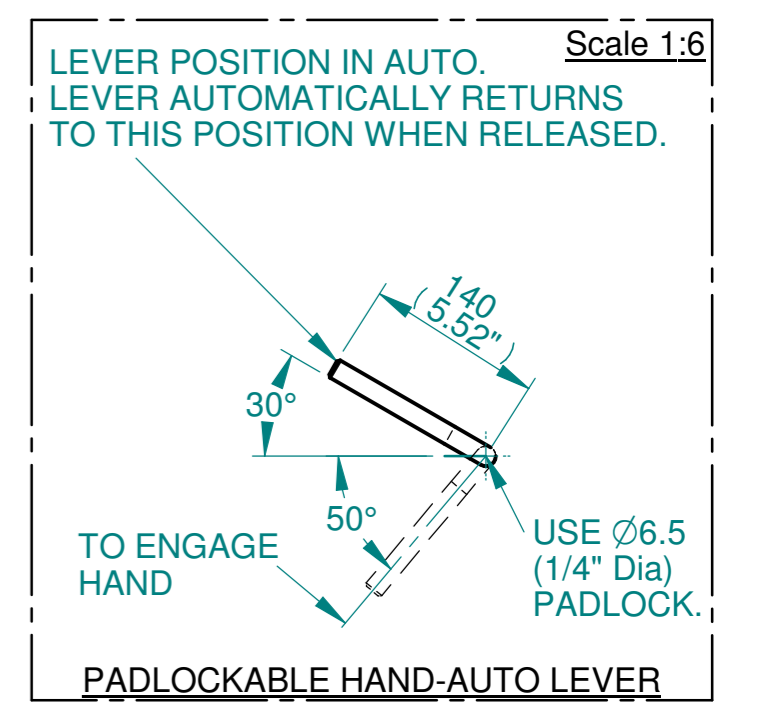
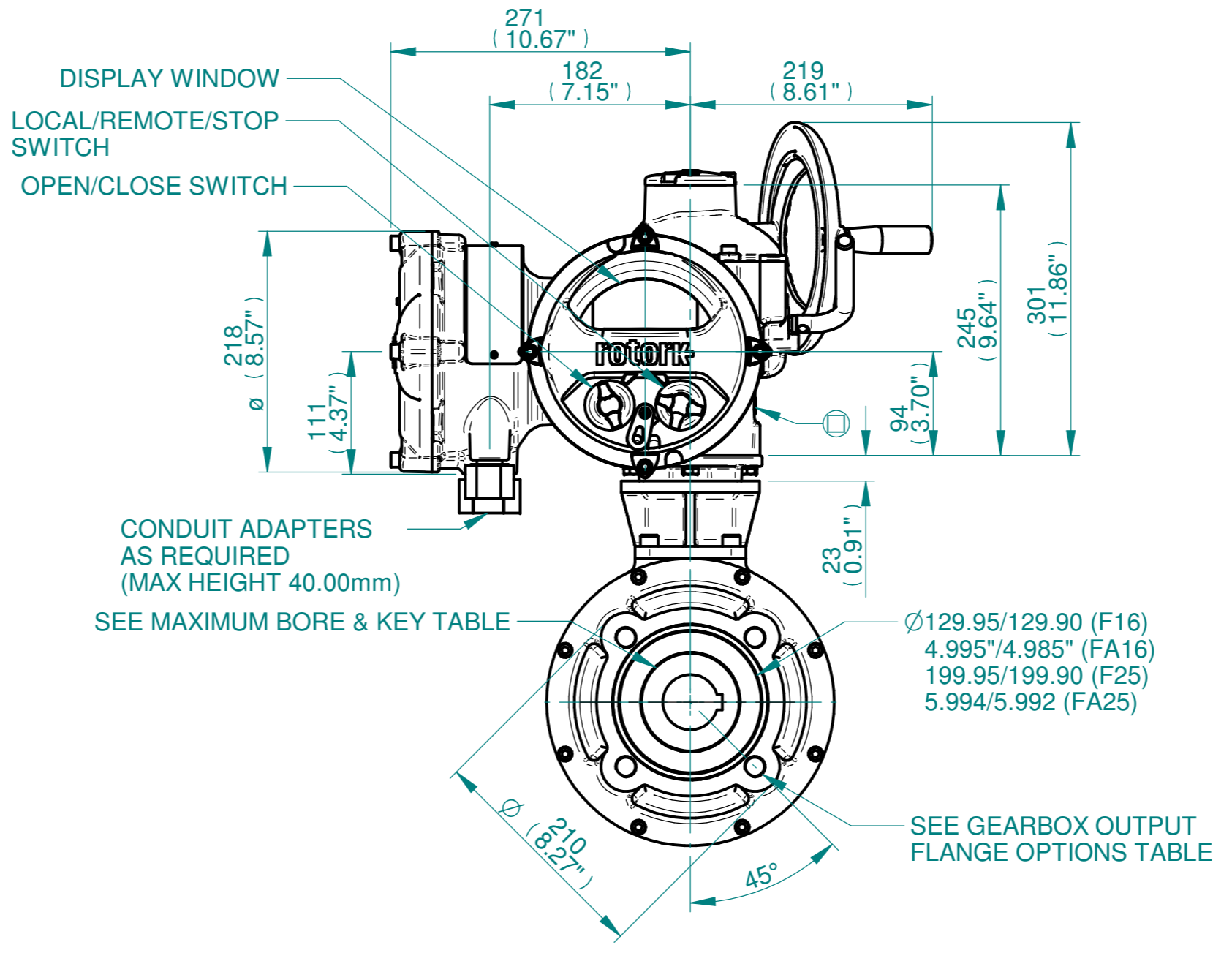
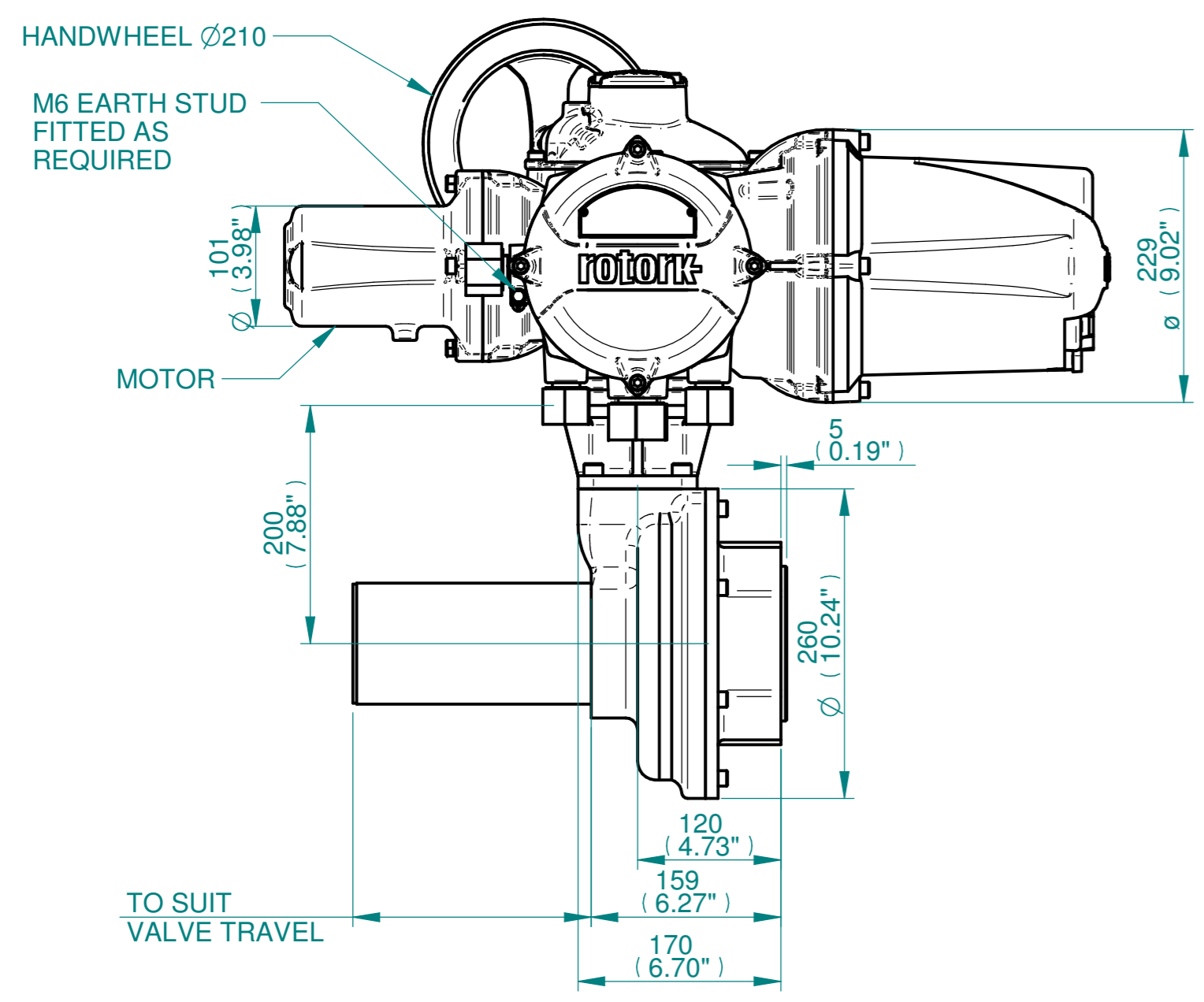

Actuator Size: IQ10/12/18, IB7, F16/F25/FA16/FA25		Gearbox output flange options								Maximum Bore & Key		
Title IQ10/12/18, SIDE HANDWHEEL, IB7 F16/F25/FA16/FA25, Ratios 3:1, 4:1 & 6:1 Installation Details Drawn JLF Checked NJC Date 11-MAR-15 Ref SALES Project Ref QUOTATION	Designation	F16	F25	-	-	FA16	FA25	-	-	Key form	Ø Bore	Key size
	No. Holes	4	8	-	-	4	8	-	-	Rectangle (BS4235)	68	20 X 12
	Hole size	M20	M16	-	-	3/4" UNC	5/8" UNC	-	-	Rectangle (ANSI B17.1)	2-5/8"	5/8 X 7/16"
	PCD	165	254	-	-	6.5"	10"	-	-	Square (ANSI B17.1)	2-1/2"	5/8"

Issue	Description
2	4 ENTRY CHANGE

Scale: 1:5 THIRD ANGLE PROJECTION

Drawing Number	Issue No	Sheet No
I11SHWIB7STD	2	1 of 1

1 2 3 4 5 6 7 8 9 10 11 12