

H  
G  
F  
E  
D  
C  
B  
A

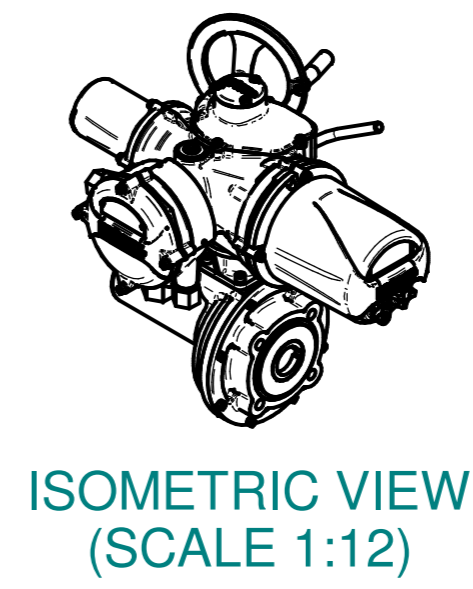

**NOTES:**  
 :DIMENSIONS WITH "\*" INDICATE COVER REMOVAL ALLOWANCE  
 :ELECTRONICS COVER OPTION "\*\*\*\*" WILL VARY DEPENDING ON CONFIGURATION  
 :NETT WEIGHT = F14:59kg/130lbs, F16:63kg/139lbs  
 : = OIL FILLER/DRAIN PLUG  
 :THE INTERFACE PROVIDED FOR MOUNTING THE ACTUATOR OR SECOND STAGE GEARBOX ONTO THE VALVE SHOULD CONFORM TO GOOD ENGINEERING PRACTICES, ENSURING ADEQUATELY TOLERANCED LIMITS FOR PARALLELISM, PERPENDICULARITY AND CONCENTRICITY.  
 :ROTORC KAN NOT BE HELD LIABLE FOR DAMAGE TO OUR EQUIPMENT CAUSED BY EXCESSIVE LOADING FROM COVER TUBES. (SEE ALSO PUB000-124)  
**CONDUIT ENTRIES**

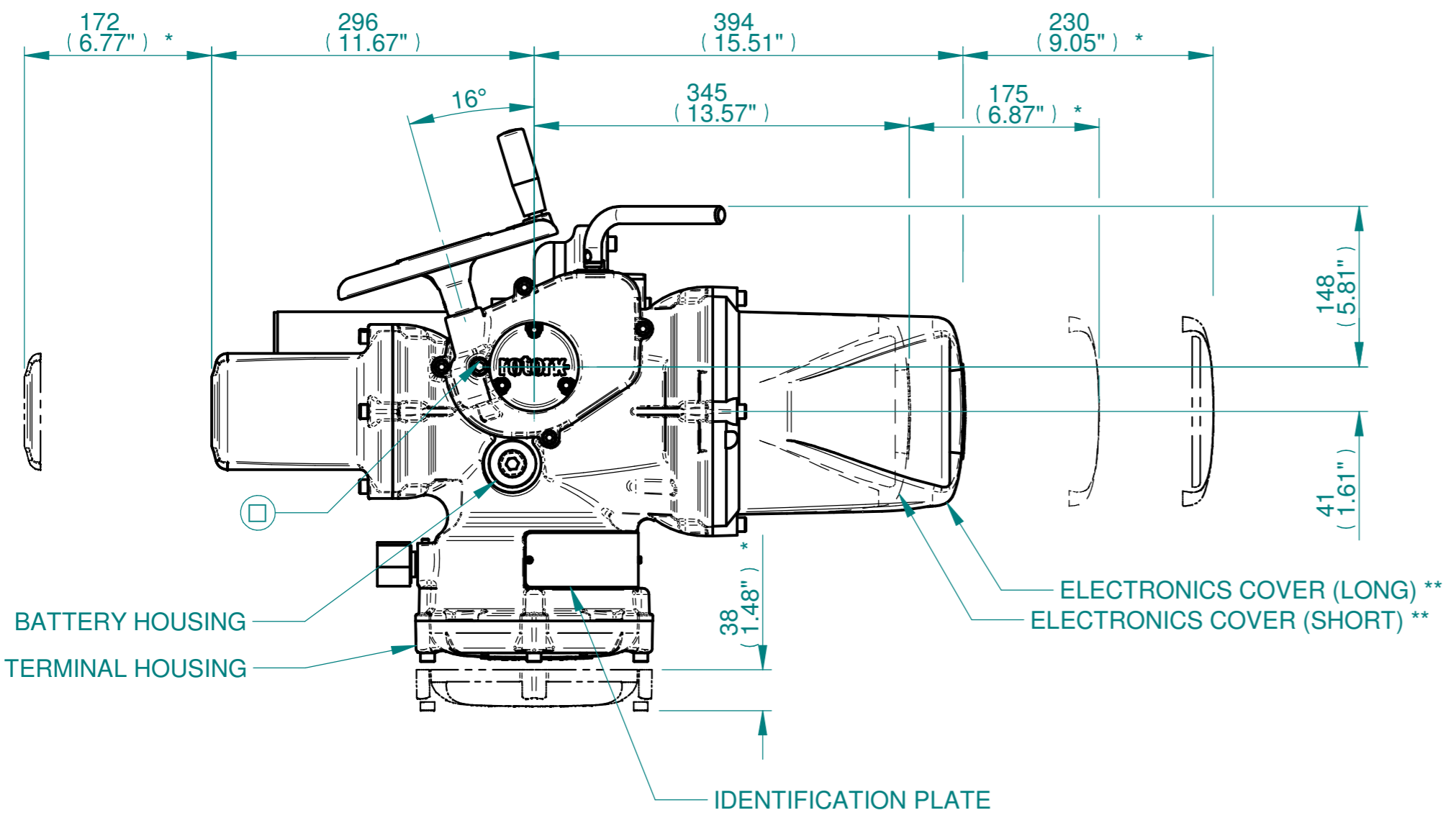
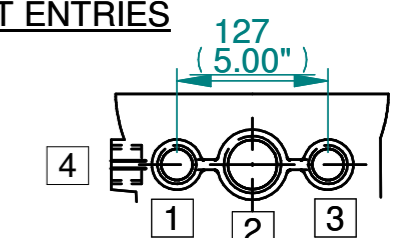

	Hole 1	Hole 2	Hole 3	Hole 4
Size	As Required	As Required	As Required	As Required
Plugged	As Required	As Required	As Required	As Required
Gland	As Required	As Required	As Required	As Required

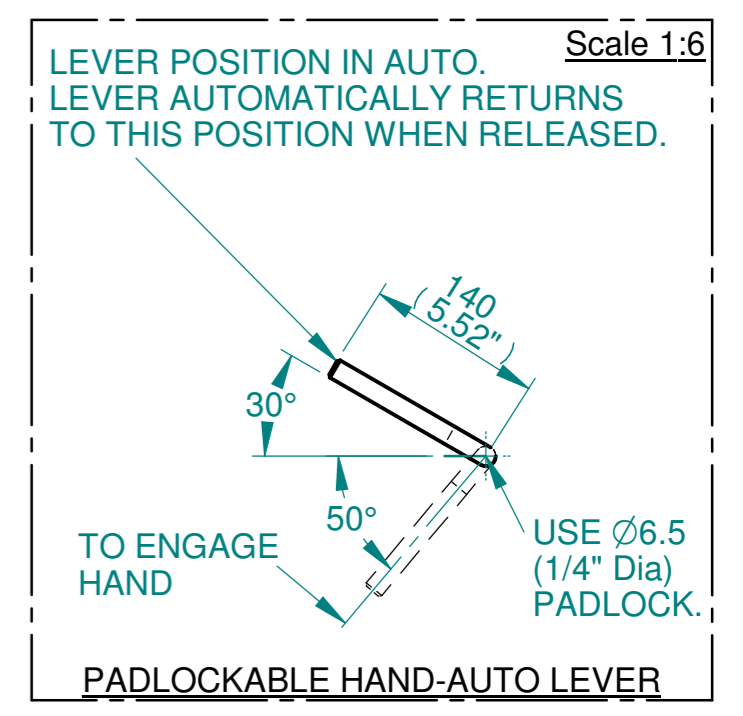
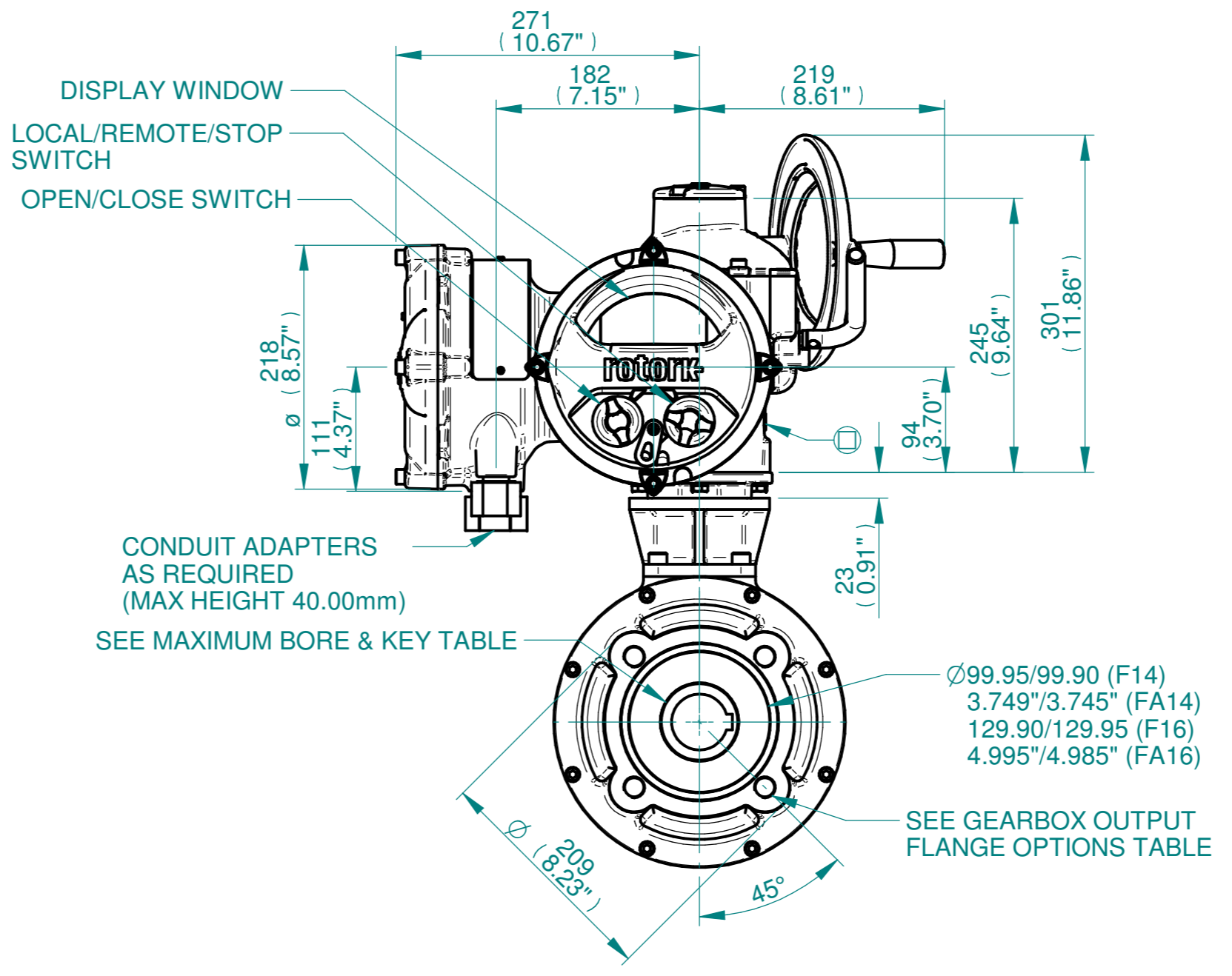
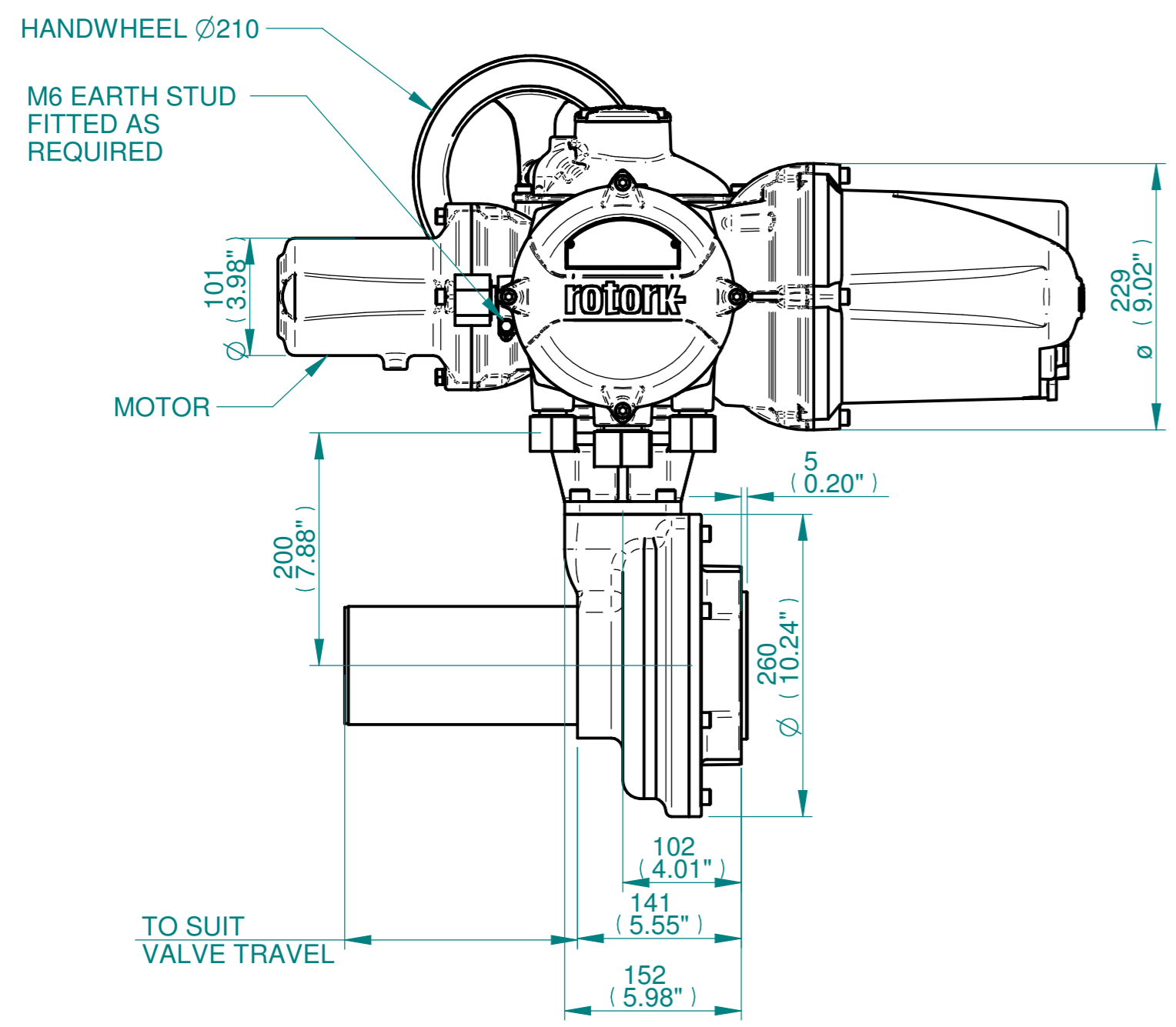

**rotork**  
 www.rotork.com  
 Rotork Controls Limited  
 Bath, BA1 3JQ, England.  
 Telephone 01225-733200

Actuator Size: IQ10/12/18, IB6, F14/F16/FA14/FA16		Gearbox output flange options								Maximum Bore & Key		
Title IQ 10/12/18, SIDE HANDWHEEL, IB6 F14/FA14/F16/FA16, Ratios 3:1,4:1 & 6:1 Installation Details Drawn JLF Checked NJC Date 11-MAR-15 Ref SALES Project Ref QUOTATION	Designation	F14	F16	-	-	FA14	FA16	-	-	Key form	Ø Bore	Key size
	No. Holes	4	4	-	-	4	4	-	-	Rectangle (BS4235)	52	16 X 10
	Hole size	M16	M20	-	-	5/8" UNC	3/4" UNC	-	-	Rectangle (ANSI B17.1)	2"	1/2 X 3/8"
	PCD	140	165	-	-	5.5"	6.5"	-	-	Square (ANSI B17.1)	1-7/8"	1/2"

Issue	Description
2	4 ENTRY CHANGE

Scale: 1:5 THIRD ANGLE PROJECTION

Drawing Number	Issue No	Sheet No
I11SHWIB6STD	2	1 of 1

1 2 3 4 5 6 7 8 9 10 11 12