

H
G
F
E
D
C
B
A

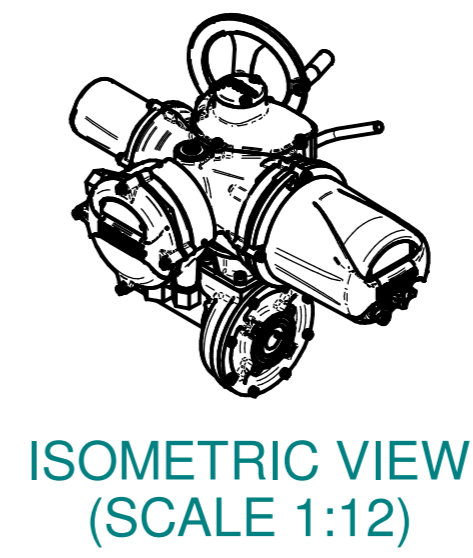

NOTES:
 :DIMENSIONS WITH "*" INDICATE COVER REMOVAL ALLOWANCE
 :ELECTRONICS COVER OPTION "****" WILL VARY DEPENDING ON CONFIGURATION
 :NETT WEIGHT = 47kg/103lbs
 : = OIL FILLER/DRAIN PLUG
 :THE INTERFACE PROVIDED FOR MOUNTING THE ACTUATOR OR SECOND STAGE GEARBOX ONTO THE VALVE SHOULD CONFORM TO GOOD ENGINEERING PRACTICES, ENSURING ADEQUATELY TOLERANCED LIMITS FOR PARALLELISM, PERPENDICULARITY AND CONCENTRICITY.
 :ROTORK CANNOT BE HELD LIABLE FOR DAMAGE TO OUR EQUIPMENT CAUSED BY EXCESSIVE LOADING FROM COVER TUBES. (SEE ALSO PUB000-124)

CONDUIT ENTRIES

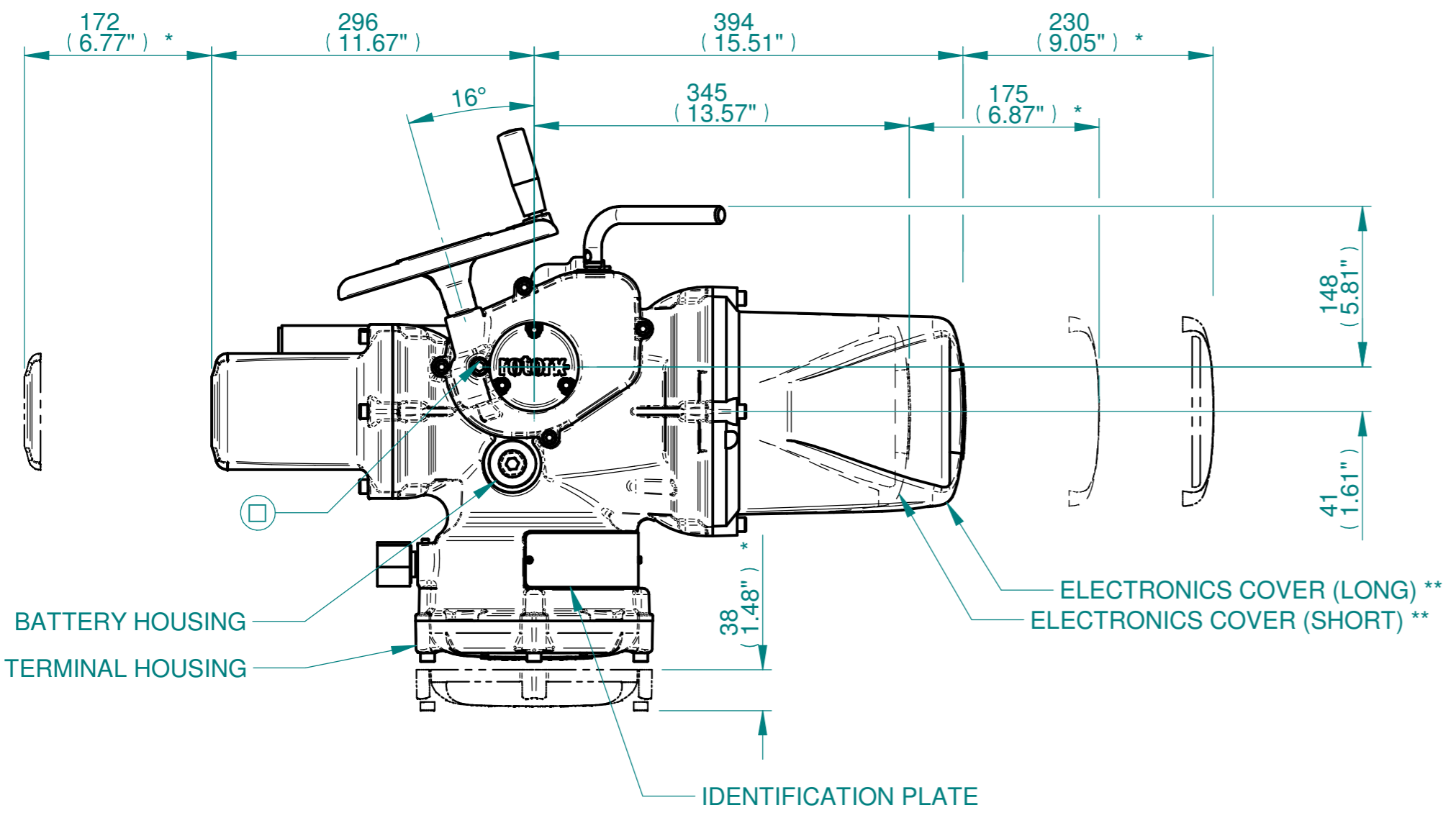
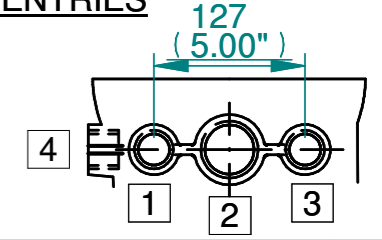

	Hole 1	Hole 2	Hole 3	Hole 4
Size	As Required	As Required	As Required	As Required
Plugged	As Required	As Required	As Required	As Required
Gland	As Required	As Required	As Required	As Required

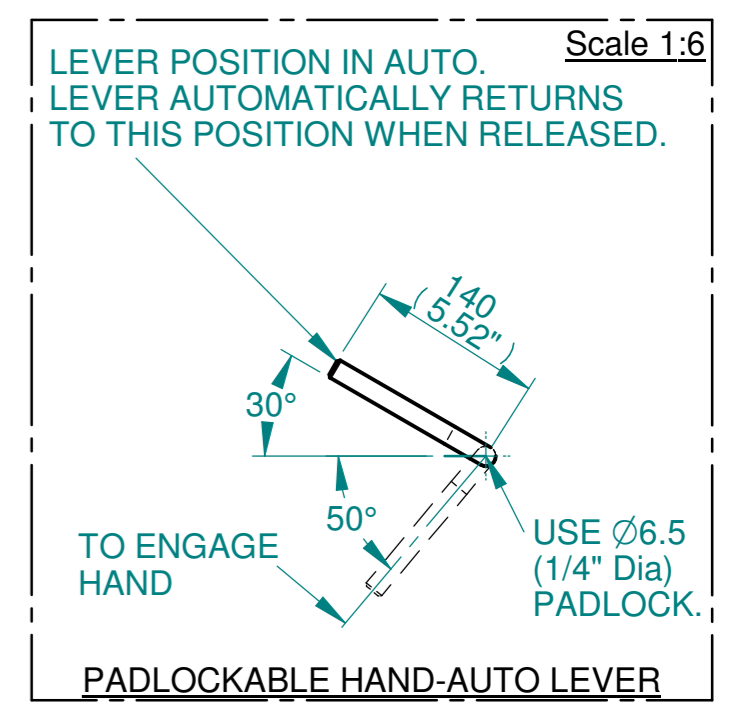
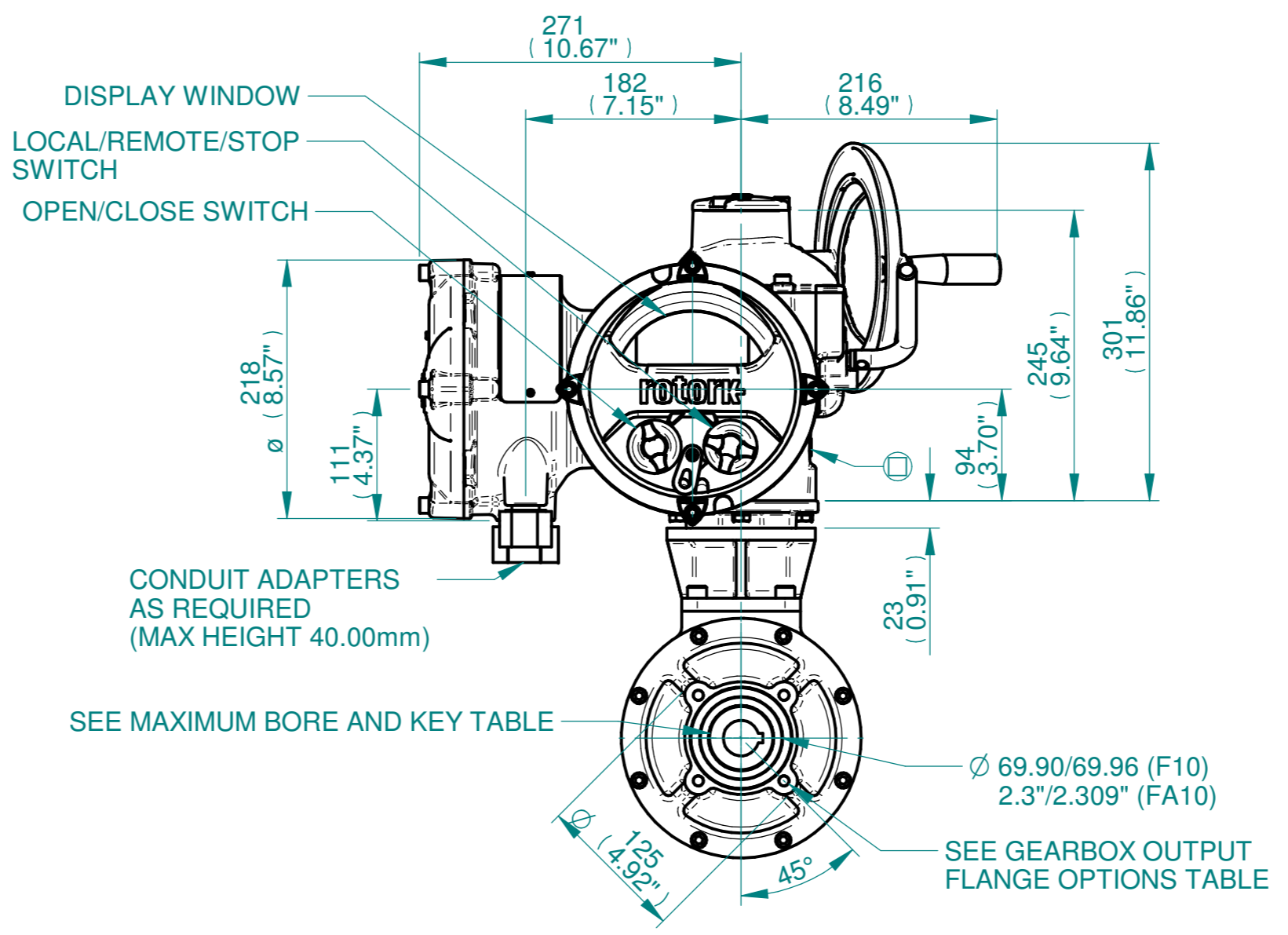
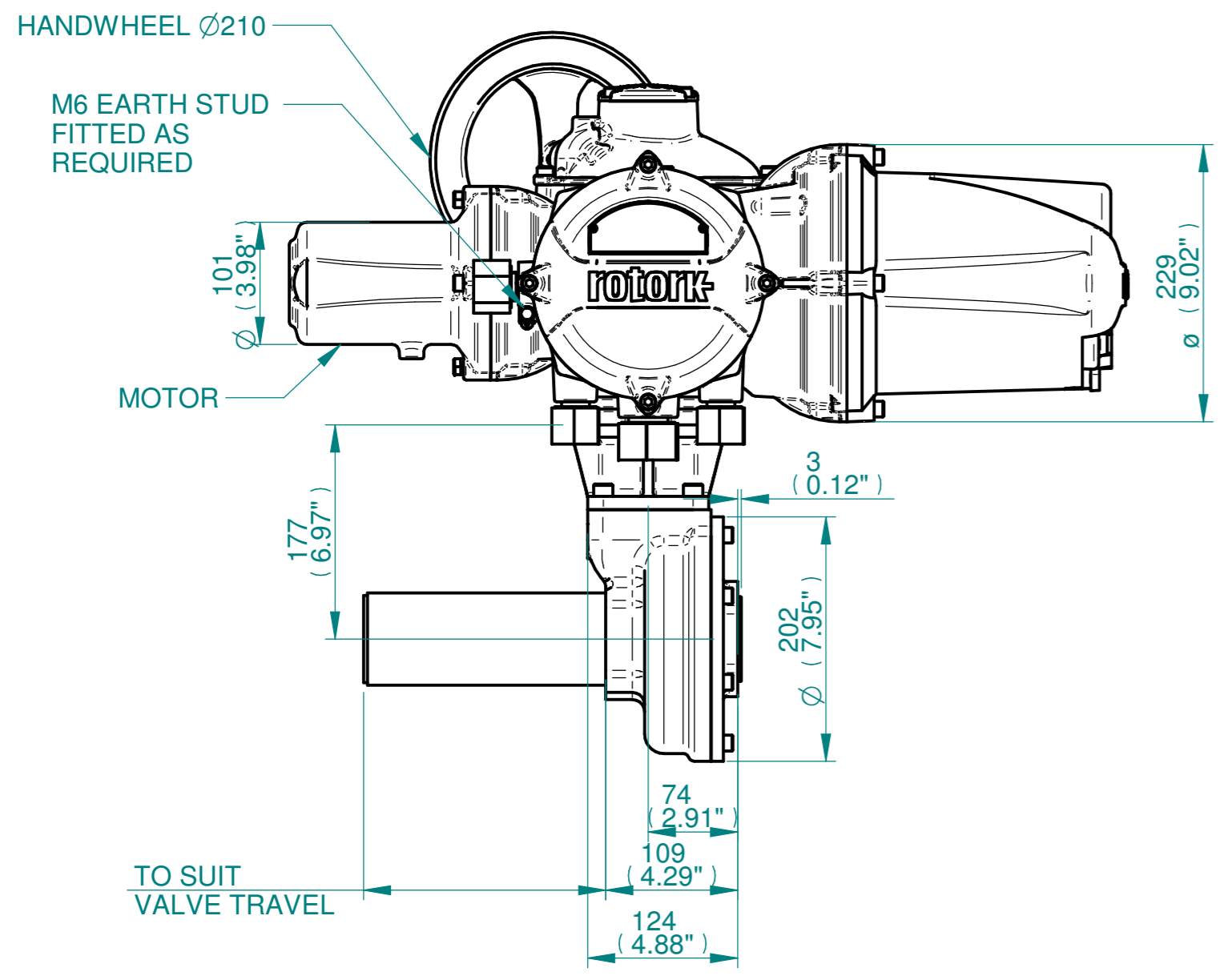

Actuator Size: IQ10/12/18, IB4, F10/FA10		Gearbox output flange options								Maximum Bore & Key			
Title IQ10/12/18, SIDE HANDWHEEL, IB4, F10/FA10, Ratios 2:1,3:1,4:1 & 6:1, Installation Details Drawn JLF Checked NJC Date 11-MAR-15 Ref SALES Project Ref QUOTATION	Designation	F10	-	-	-	-	FA10	-	-	-	Key form	Ø Bore	Key size
	No. Holes	4	-	-	-	-	4	-	-	-	Rectangle (BS4235)	40	12 X 8
	Hole size	M10	-	-	-	-	3/8" UNC	-	-	-	Rectangle (ANSI B17.1)	1-5/8"	3/8 X 1/4"
	PCD	102	-	-	-	-	4"	-	-	-	Square (ANSI B17.1)	1-1/2"	3/8"

Issue	Description
2	4 ENTRY CHANGE

Scale: 1:5 THIRD ANGLE PROJECTION

Drawing Number	Issue No	Sheet No
111SHWIB4STD	2	1 of 1

1 2 3 4 5 6 7 8 9 10 11 12