

SEE TABLE FOR BASEPLATE DETAILS

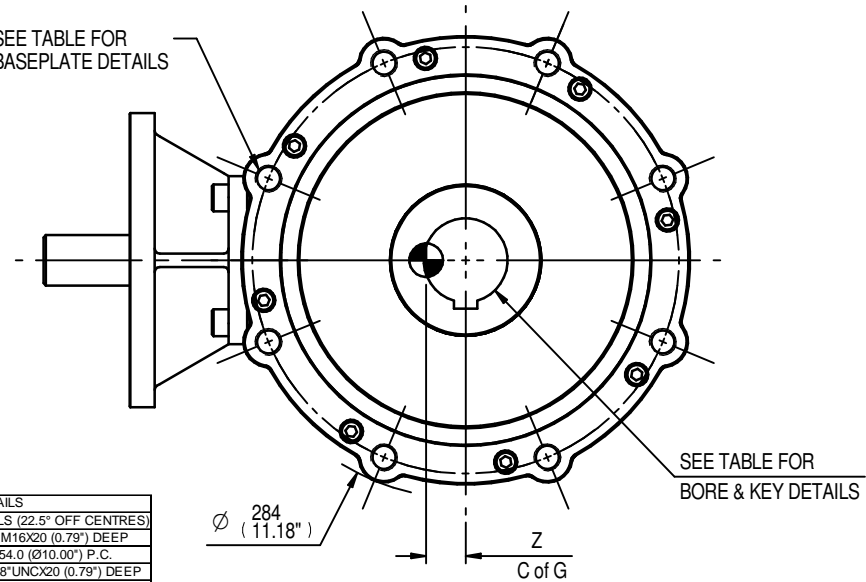

RATIO	M.A.	C.O.G.			MAX OUTPUT TORQUE Nm (lbs.ft)
		X	Y	Z	
3	2.55	0	54	24	1355 (1000)
4	3.40	0	54	23	1355 (1000)
6	5.10	0	54	22	1084 (800)

MAX BORE SQ KEY			MAX BORE RECTANGULAR KEY		
STD	BORE	KEY	STD	BORE	KEY
BS4235	-	-	BS4235	68.0	20x12
BS46	2.500" 5/8" SQ		BS46	2.625"	3/4"x1/2"
ANSI B17.1	2.500" 5/8" SQ		ANSI B17.1	2.625"	5/8"x7/16"

MAX STEM SCREW ACCEPTANCE DIA
73(2.750")

	INPUT FLANGE DETAILS					
	FLANGE O/DIA. & THICKNESS	SHAFT DIA.	RECESS DIA.	RECESS DEPTH	HOLE DETAILS 45°(OFF CENTRES)	KEY DETAILS
ISO F14	Ø175 x 15 (Ø6.89" x 0.59")	Ø30.00±0.05 (Ø1.181"±0.002")	Ø100.05±0.05 (Ø3.938"±0.002")	5 (0.20")	4 HOLES Ø16.5 (Ø0.65") ON Ø140.0 (Ø5.51") P.C	8x7x40 (0.31"x0.28"x1.57")
	Ø175 x 15 (Ø6.89" x 0.59")	Ø30.00±0.05 (Ø1.181"±0.002")	Ø95.27±0.05 (Ø3.751"±0.002")	5 (0.20")	4 HOLES Ø16.5 (Ø0.65") ON Ø140.0 (Ø5.51") P.C	8x7x40 (0.31"x0.28"x1.57")

	BASEPLATE DETAILS	
	SPIGOT DIA.	HOLE DETAILS (22.5° OFF CENTRES)
ISO F25	Ø199.95±0.05 (Ø7.872"±0.002")	8 HOLES M16X20 (0.79") DEEP ON Ø254.0 (Ø10.00") P.C.
	Ø152.25±0.05 (Ø5.994"±0.002")	8 HOLES 5/8"UNCX20 (0.79") DEEP ON Ø254.4 (Ø10.00") P.C.

**rotork gears**

IB7 GEARBOX  
F14/FA14 INPUT F25/FA25 OUTPUT

DETAILS SUBJECT TO CHANGE WITHOUT PRIOR NOTICE

FOR UP TO DATE DETAILS VISIT [www.rotork.com](http://www.rotork.com)

APPROX WEIGHT 42.6 kg

DRAWING No	PUBIB7-F14-F25	Regina House Ring Road Bramley Leeds LS134ET United Kingdom
ISSUE	A	
DATE	05/05/2011	