

SEE TABLE FOR
BASEPLATE
HOLE DETAILS

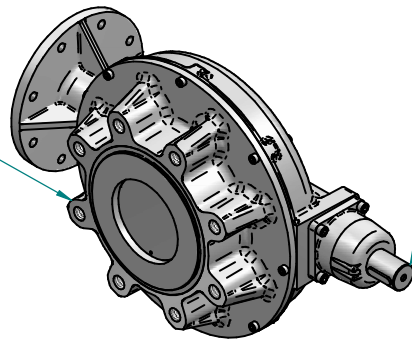

X4
SECONDARY
INPUT

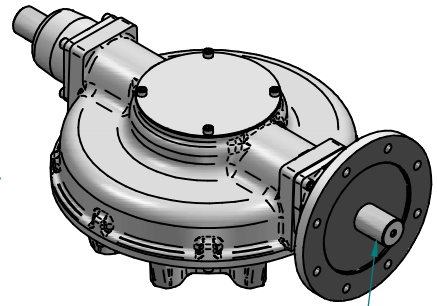

X2
PRIMARY
INPUT

F35/FA35 BASEPLATE DETAILS		
	SPIGOT DIA.	HOLE DETAILS (22.5° OFF CENTRES)
ISO F35	Ø259.95 -0.05 (Ø10.234" - 0.002")	8 HOLES M30x36 (1.42") DEEP ON Ø356.0 (Ø14.02") P.C.
FA35	Ø215.80 -0.25 (Ø8.496" -0.008")	8 HOLES 1"UNCx36 (1.42") DEEP ON Ø355.6 (Ø14.00") P.C.

F40/FA40 BASEPLATE DETAILS		
	SPIGOT DIA.	HOLE DETAILS (22.5° OFF CENTRES)
ISO F40	Ø299.95 -0.05 (Ø11.809" - 0.002")	8 HOLES M36x45 (1.77") DEEP ON Ø406.0 (Ø15.98") P.C.
FA40	Ø228.60 -0.15 (Ø9.000" -0.006")	8 HOLES 1.25"UNCx45 (1.77") DEEP ON Ø406.4 (Ø16.00") P.C.

MOTORISED INPUT FLANGE DETAILS					
	FLANGE O/DIA. & THICKNESS	SHAFT DIA.	RECESS DIA.	HOLE DETAILS (OFF CENTRES)	KEY DETAILS
ISO F14	Ø175 (Ø6.89") x 15 (0.59")	Ø30.00 -0.05 (Ø1.181" -0.002")	Ø100.05 +0.05 (Ø3.939" +0.002")	4 HOLES Ø16.5 (Ø0.65") ON Ø140.0 (Ø5.51") P.C.	KEY 8x7x55 (0.31"x0.28"x2.17")
FA14	Ø175 (Ø6.89") x 15 (0.59")	Ø30.00 -0.05 (Ø1.181" -0.002")	Ø95.27 +0.05 (Ø3.751" +0.002")	4 HOLES Ø16.5 (Ø0.65") ON Ø140.0 (Ø5.51") P.C.	KEY 8x7x55 (0.31"x0.28"x2.17")
ISO F16	Ø210 (Ø8.27") x 20 (0.79")	Ø40.00 -0.05 (Ø1.575" -0.002")	Ø130.05 +0.05 (Ø5.120" +0.002")	4 HOLES Ø20.5 (Ø0.81") ON Ø165.0 (Ø6.50") P.C.	KEY 12x8x55 (0.47"x0.31"x2.17")
FA16	Ø210 (Ø8.27") x 20 (0.79")	Ø40.00 -0.05 (Ø1.575" -0.002")	Ø126.92 +0.05 (Ø4.997" +0.002")	4 HOLES Ø20.5 (Ø0.81") ON Ø165.0 (Ø6.50") P.C.	KEY 12x8x55 (0.47"x0.31"x2.17")
ISO F25	Ø300 (Ø11.81") x 20 (0.79")	Ø50.00 -0.05 (Ø1.969" -0.002")	Ø200.10 +0.10 (Ø7.878" +0.004")	8 HOLES Ø16.5 (Ø0.65") ON Ø254.0 (Ø10.00") P.C.	KEY 14x9x55 (0.55"x0.35"x2.17")
FA25	Ø300 (Ø11.81") x 20 (0.79")	Ø50.00 -0.05 (Ø1.969" -0.002")	Ø152.37 +0.10 (Ø5.999" +0.004")	8 HOLES Ø16.5 (Ø0.65") ON Ø254.0 (Ø10.00") P.C.	KEY 14x9x55 (0.55"x0.35"x2.17")

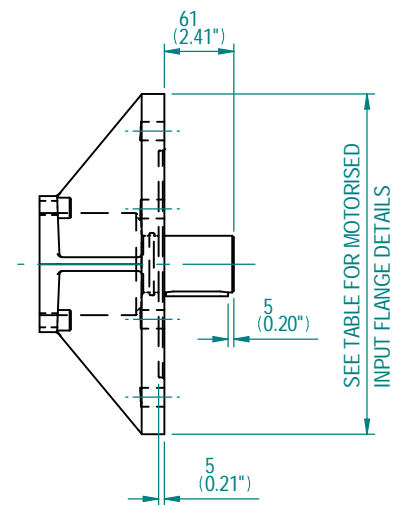

ROTORK GEARS
9 BROWN LANE WEST
LEEDS
WEST YORKSHIRE
LS12 6BH
UNITED KINGDOM

IB13 DUAL INPUTS AT 180° BEVEL GEARCASE

DETAILS SUBJECT TO CHANGE WITHOUT PRIOR NOTICE

FOR UP TO DATE DETAILS VISIT www.rotork.com

ISSUE :-	0-0	SCALE :-	1 : 6.5 (A4)
DATE :-	30/06/2021		
DRAWING No :-	PUB-IB13-DUAL180		