

SEE TABLE FOR  
BASEPLATE  
HOLE DETAILS

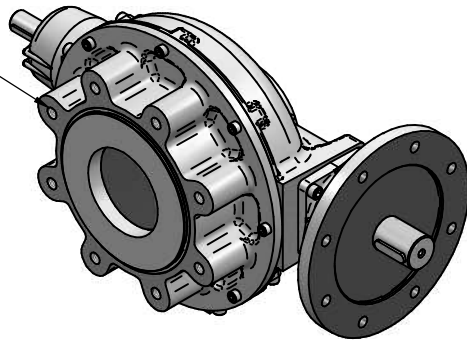

X2  
PRIMARY  
INPUT

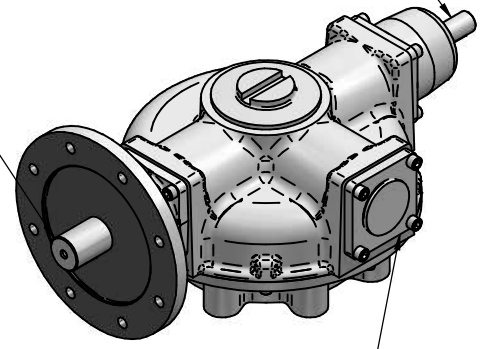

X4  
SECONDARY  
INPUT

X1  
BLANK OFF

BASEPLATE DETAILS		
	SPIGOT DIA.	HOLE DETAILS (22.5° OFF CENTRES)
ISO F30	Ø229.95 -0.05 (Ø9.053" -0.002")	8 HOLES M20x25 (0.98") DEEP ON Ø298 (Ø11.73") P.C.
FA30	Ø177.70 -0.05 (Ø6.996" -0.002")	8 HOLES 3/4"UNCx25 (0.98") DEEP ON Ø298.5 (Ø11.75") P.C.

MOTORISED INPUT FLANGE DETAILS					
	FLANGE O/DIA. & THICKNESS	SHAFT DIA.	RECESS DIA.	HOLE DETAILS (OFF CENTRES)	KEY DETAILS
ISO F14	Ø175 (Ø6.89") x 15 (0.59")	Ø30.00 -0.05 (Ø1.181" -0.002")	Ø100.05 +0.05 (Ø3.939" +0.002")	4 HOLES Ø16.5 (Ø0.65") ON Ø140.0 (Ø5.51") P.C.	KEY 8x7x55 (0.31"x0.28"x2.17")
FA14	Ø175 (Ø6.89") x 15 (0.59")	Ø30.00 -0.05 (Ø1.181" -0.002")	Ø95.27 +0.05 (Ø3.751" +0.002")	4 HOLES Ø16.5 (Ø0.65") ON Ø140.0 (Ø5.51") P.C.	KEY 8x7x55 (0.31"x0.28"x2.17")
ISO F16	Ø210 (Ø8.27") x 20 (0.79")	Ø40.00 -0.05 (Ø1.575" -0.002")	Ø130.05 +0.05 (Ø5.120" +0.002")	4 HOLES Ø20.5 (Ø0.81") ON Ø165.0 (Ø6.50") P.C.	KEY 12x8x55 (0.47"x0.31"x2.17")
FA16	Ø210 (Ø8.27") x 20 (0.79")	Ø40.00 -0.05 (Ø1.575" -0.002")	Ø126.92 +0.05 (Ø4.997" +0.002")	4 HOLES Ø20.5 (Ø0.81") ON Ø165.0 (Ø6.50") P.C.	KEY 12x8x55 (0.47"x0.31"x2.17")
ISO F25	Ø300 (Ø11.81") x 20 (0.79")	Ø50.00 -0.05 (Ø1.969" -0.002")	Ø200.10 +0.10 (Ø7.878" +0.004")	8 HOLES Ø16.5 (Ø0.65") ON Ø254.0 (Ø10.00") P.C.	KEY 14x9x55 (0.55"x0.35"x2.17")
FA25	Ø300 (Ø11.81") x 20 (0.79")	Ø50.00 -0.05 (Ø1.969" -0.002")	Ø152.37 +0.10 (Ø5.999" +0.004")	8 HOLES Ø16.5 (Ø0.65") ON Ø254.0 (Ø10.00") P.C.	KEY 14x9x55 (0.55"x0.35"x2.17")

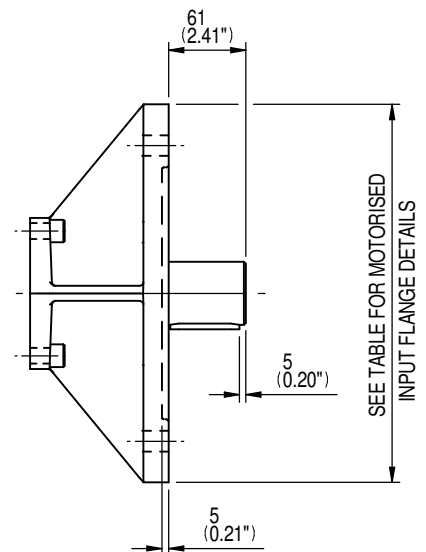

**ROTORK GEARS**  
9 BROWN LANE WEST  
LEEDS  
WEST YORKSHIRE  
LS12 6BH  
UNITED KINGDOM

## IB11 DUAL INPUTS AT 180° BEVEL GEARCASE

DETAILS SUBJECT TO CHANGE WITHOUT PRIOR NOTICE

FOR UP TO DATE DETAILS VISIT [www.rotork.com](http://www.rotork.com)

ISSUE :-	01	SCALE :-	1 : 5.5 (A4)
DATE :-	14/02/2019		
DRAWING No :-	PUB-IB11-DUAL180		