

1	2		3		4		5		6		7		8				
INPUT FLANGE DETAILS					MOUNTING HOLES - BOLT CIRCLE (OFF CENTRES)					STEM ACCEPTANCE IN ACCORDANCE TO STANDARD							
INPUT FLANGE	FLANGE O/DIA.	SHAFT DIA.	RECESS DIA.	RECESS DEPTH	HOLE DETAILS (OFF CENTRES)	KEY DETAILS	ISO 5211 / MSS SP-101 MOUNTING OPTION	HOLE DETAILS (OFF CENTRES)	MAX OUTSIDE DIA. INCLUDING DRILLED HOLES	MIN INSIDE DIA. INCLUDING DRILLED HOLES	SQ BORE MAX	STANDARD	MIN BORE	SQ KEY MAX BORE	SQ KEY SIZE	RECT. KEY MAX BORE	RECT KEY SIZE
E-FLANGE	Ø125 (Ø4.92")	Ø19.98-0.05 (Ø0.79"-0.002")	Ø70+0.07 (Ø2.76"+0.003")	4 (0.16")	4x Ø11 ON A Ø102P.C. (4x Ø0.43" ON A Ø4.02" P.C.)	6x6x36 (0.24"x0.24"x1.42")	ISO F25	8 x M16 x 24 (0.94") DEEP ON Ø254.0 (Ø10.00") P.C.	Ø442 (17.40")	Ø222 (8.74")	□ 122.9 (4.84")	BS4235	-	-	-	157	40 x 22
							FA25	8 x 5/8" UNC x 24 (0.94") DEEP ON Ø254.0 (Ø10.00") P.C.				BS46	-	5.625"	1.1/2" SQ.	6.00"	1.1/2" x 1"
												ANSI B17.1	-	5.625"	1.1/2" SQ.	6.00"	1.1/2" x 1"
												DIN 6885	-	-	-	157	40 x 22

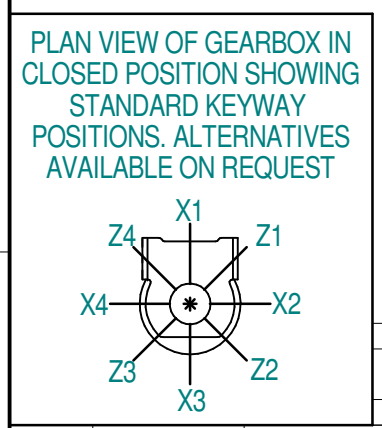
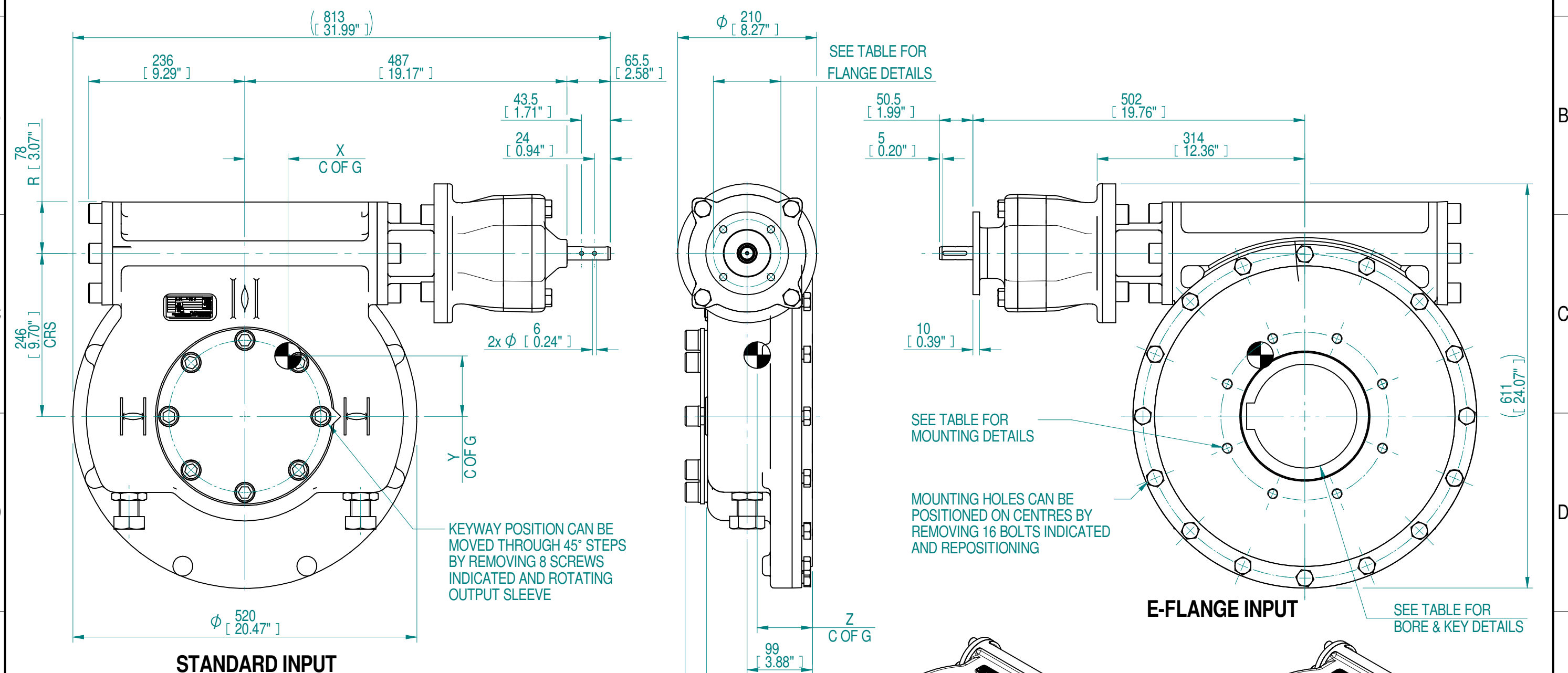

- NOTES:
- OTHER INPUT AND OUTPUT OPTIONS AVAILABLE - SEE 'HOW GEARBOX BROCHURE' AT WWW.ROTORK.COM FOR FURTHER DETAILS.
 - CENTRE OF GRAVITY POSITION IS INDICATIVE FOR STANDARD BUILD WHEN IN POSITION SHOWN.

1766	442	441.6	48100	109	65	91	83
RATIO	TURNS TO CLOSE	M.A. ± 15%	MAX OUTPUT (Nm)	MAX INPUT (Nm)	X	Y	Z
DESCRIPTION				CENTRE OF GRAVITY			

0-0		M.Jones	N.Coope	2019-10-11	First issue			
Rev	ECN	Revised	Rev. Approved	Date	Change Description			

LEEDS - UK
www.rotork.com

©2019 Rotork Group of Companies. All rights reserved. This document and its contents may not be reproduced, distributed, transmitted, displayed, published, or broadcast, in whole, or in part, without the prior, express written permission of Rotork Group of Companies.

Dimensions in mm
Scale 1:6

Created M.Jones 2019-06-26
Checked
Approved N.Coope 2019-10-11

Title **HOW82-MPR28 QUARTER TURN GEARBOX 1766:1**

Drawing Number **PUB-HOW82-MPR28** Rev 0-0

Nominal Mass **181.45 kg** Size A3 Sheet 1 of 1