

INPUT FLANGE DETAILS							MOUNTING HOLES - BOLT CIRCLE (OFF CENTRES)				STEM ACCEPTANCE IN ACCORDANCE TO STANDARD						
INPUT FLANGE	FLANGE O/DIA.	SHAFT DIA.	RECESS DIA.	RECESS DEPTH	HOLE DETAILS (OFF CENTRES)	KEY DETAILS	ISO 5211 / MSS SP-101 MOUNTING OPTION	HOLE DETAILS (OFF CENTRES)	MAX OUTSIDE DIA. INCLUDING DRILLED HOLES	MIN INSIDE DIA. INCLUDING DRILLED HOLES	SQ BORE MAX	STANDARD	MIN BORE	SQ KEY MAX BORE	SQ KEY SIZE	RECT. KEY MAX BORE	RECT KEY SIZE
E-FLANGE	Ø125 (Ø4.92")	Ø19.98-0.05 (Ø0.79"-0.002")	Ø70+0.07 (Ø2.76"+0.003")	4 (0.16")	4x Ø11 ON A Ø102P.C. (4x Ø0.43" ON A Ø4.02" P.C.)	6x6x36 (0.24"x0.24"x1.42")	ISO F60*	20 x M36 x 38 (1.49") DEEP ON Ø603.0 (Ø23.74") P.C.	Ø835 (32.87")	Ø436 (17.16")	□ 229.5 (9.03")	BS4235	-	-	-	305	70x36
							FA60*	20 x 1.25" UNC x 38 (1.49") DEEP ON Ø603.0 (Ø23.74") P.C.				BS46	-	-	-	12"	3" x 2"
												ANSI B17.1	-	11.75"	3" SQ.	12"	3" x 2"
												DIN 6885	-	-	-	-	-

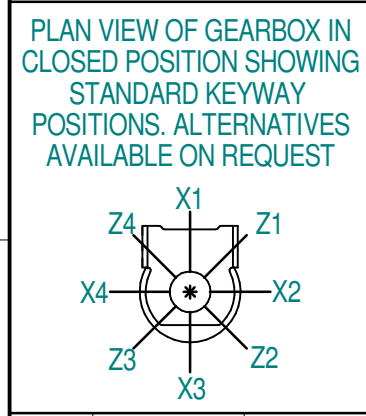
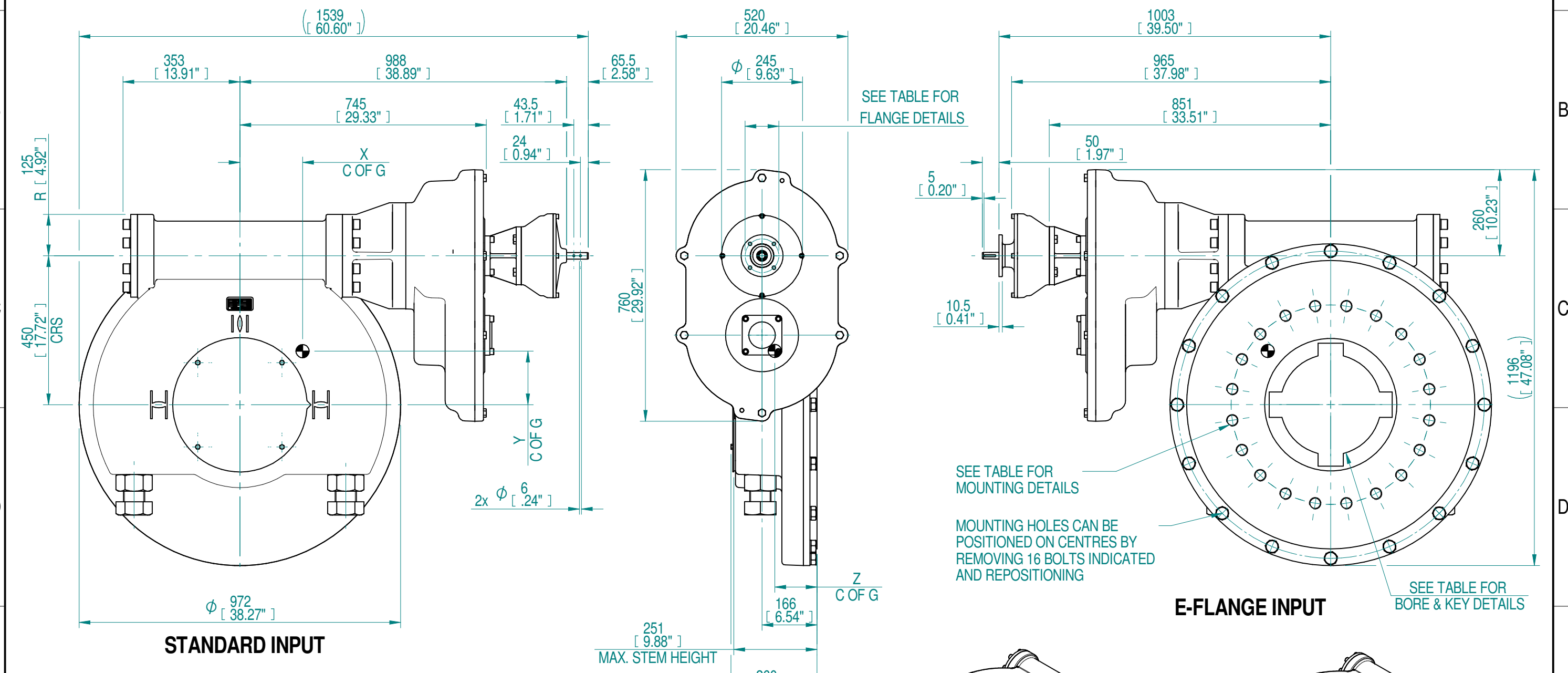

- NOTES:**
- OTHER INPUT AND OUTPUT OPTIONS AVAILABLE - SEE 'HOW GEARBOX BROCHURE' AT WWW.ROTORK.COM FOR FURTHER DETAILS.
 - CENTRE OF GRAVITY POSITION IS INDICATIVE FOR STANDARD BUILD WHEN IN POSITION SHOWN.
 - * THREAD DEPTH DOES NOT MATCH ISO STANDARD.

7171	1793	2240.4	264000	118	189	162	127
RATIO	TURNS TO CLOSE	M.A. ± 15%	MAX OUTPUT (Nm)	MAX INPUT (Nm)	X	Y	Z
DESCRIPTION				CENTRE OF GRAVITY			

0-0		M.Jones	N.Coope	2019-10-11	First issue			
Rev	ECN	Revised	Rev. Approved	Date	Change Description			

LEEDS - UK
www.rotork.com

©2019 Rotork Group of Companies. All rights reserved. This document and its contents may not be reproduced, distributed, transmitted, displayed, published, or broadcast, in whole, or in part, without the prior, express written permission of Rotork Group of Companies.

Dimensions in mm
Scale 1:12

Title **HOW13 IR4 12" BASE MPR10 7171:1 QUARTER TURN GEARBOX**

Drawing Number **PUB-HOW13-IR4-10-MPR10-12**

Nominal Mass **1037.81 kg** Size **A3** Sheet **1** of **1**

Created	M.Jones	2019-06-27
Checked		
Approved	N.Coope	2019-10-11

Template Issue - 2018-05-10