

INPUT FLANGE DETAILS							MOUNTING HOLES - BOLT CIRCLE (OFF CENTRES)				STEM ACCEPTANCE IN ACCORDANCE TO STANDARD						
INPUT FLANGE	FLANGE O/DIA.	SHAFT DIA.	RECESS DIA.	RECESS DEPTH	HOLE DETAILS (OFF CENTRES)	KEY DETAILS	ISO 5211 / MSS SP-101 MOUNTING OPTION	HOLE DETAILS (OFF CENTRES)	MAX OUTSIDE DIA. INCLUDING DRILLED HOLES	MIN INSIDE DIA. INCLUDING DRILLED HOLES	SQ BORE MAX	STANDARD	MIN BORE	SQ KEY MAX BORE	SQ KEY SIZE	RECT. KEY MAX BORE	RECT KEY SIZE
E-FLANGE	Ø125 (Ø4.92")	Ø19.98-0.05 (Ø0.79"-0.002")	Ø70+0.07 (Ø2.76"+0.003")	4 (0.16")	4x Ø11 ON A Ø102 P.C. (4x Ø0.43" ON A Ø4.02" P.C.)	6x6x36 (0.24"x0.24"x1.42")	ISO F35*	8 x M30 x 36 (1.42") DEEP ON Ø356.0 (Ø14.02") P.C.	Ø520 (20.47")	Ø291 (11.45")	□ 152.6 (6.00")	BS4235	-	-	-	203	50 x 28
							FA35*	8 x 1" UNC x 36 (1.42") DEEP ON Ø355.6 (Ø14.00") P.C.				BS46	-	-	-	7.625"	2" x 1.3/8"
												ANSI B17.1	-	7.375"	1.3/4" SQ.	7.625"	2" x 1.1/2"
							DIN 6885	-				-	-	203	50 x 28		

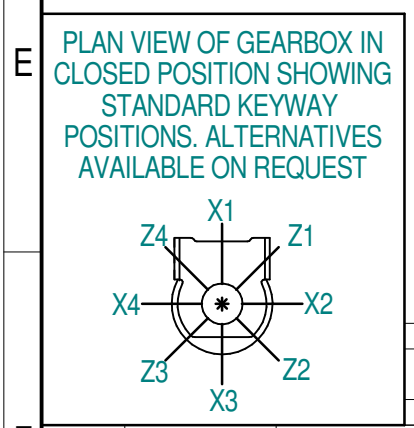
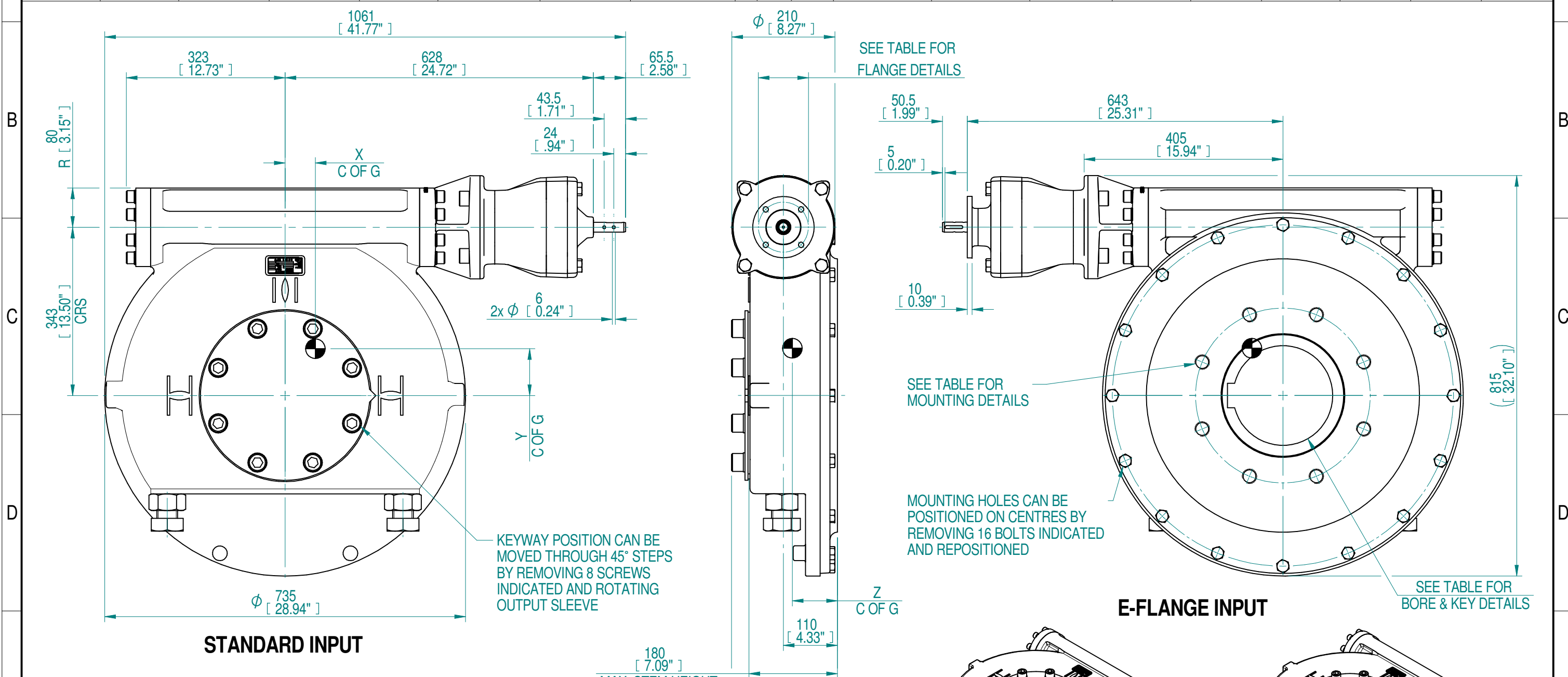

- NOTES:
- OTHER INPUT AND OUTPUT OPTIONS AVAILABLE - SEE 'HOW GEARBOX BROCHURE' AT [WWW.ROTORK.COM](http://WWW.ROTORK.COM) FOR FURTHER DETAILS.
  - CENTRE OF GRAVITY POSITION IS INDICATIVE FOR STANDARD BUILD WHEN IN POSITION SHOWN.
  - \* THREAD DEPTH DOES NOT MATCH ISO STANDARD.

2655	664	688.9	88130	128	62	96	92
RATIO	TURNS TO CLOSE	M.A. ± 15%	MAX OUTPUT (Nm)	MAX INPUT (Nm)	X	Y	Z
DESCRIPTION				CENTRE OF GRAVITY			

0-0		M.Jones	N.Coope	2019-10-11	First issue		
Rev	ECN	Revised	Rev. Approved	Date	Change Description		

LEEDS - UK  
[www.rotork.com](http://www.rotork.com)

©2019 Rotork Group of Companies. All rights reserved. This document and its contents may not be reproduced, distributed, transmitted, displayed, published, or broadcast, in whole, or in part, without the prior, express written permission of Rotork Group of Companies.

Dimensions in mm  
Scale 1:8

Title **HOW10-MPR36 QUARTER TURN GEARBOX 2655:1**

Drawing Number **PUB-HOW10-MPR36**

Rev **0-0**

Nominal Mass **377.62 kg** Size **A3** Sheet **1** of **1**