

E-FLANGE INPUT DETAILS		MOUNTING HOLES - BOLT CIRCLE (OFF CENTRES)				STEM ACCEPTANCE IN ACCORDANCE TO STANDARD											
INPUT FLANGE	FLANGE O/DIA. + THICKNESS	SHAFT DIA.	RECESS DIA.	RECESS DEPTH	HOLE DETAILS (45° OFF CENTRES)	KEY DETAILS	ISO 5211 / MSS SP-101 MOUNTING OPTION	HOLE DETAILS (22.5° OFF CENTRES)	SPIGOT DIAMETER	MAX SCREW STEM ACCEPTANCE	STANDARD	MIN BORE	SQ KEY MAX BORE	SQ KEY SIZE	RECT. KEY MAX BORE	RECT. KEY SIZE	SQ BORE MAX
-	-	19.98-0.05 (0.787"-0.002")	-	-	-	6x6x40 (0.24"x0.24"x1.57")	F35	8 x M30 x 40 (1.57") DEEP ON Ø356.0 (Ø14.02") P.C.	Ø259.95-0.05 (Ø10.234"-0.002")	127 (5.000")	BS4235	-	-	-	121.0	32 x 18	□ 86.6 (3.409")
-	-	-	-	-	-	FA35	8 x 1" UNC x 40 (1.57") DEEP ON Ø355.6 (Ø14.00") P.C.	Ø215.80-0.25 (Ø8.496"-0.008")	ANSI B17.1		-	4.500"	1 1/4" SQ.	4.625"	1 1/4" x 7/8"		
-	-	-	-	-	-	-	-	-	DIN 6885		-	-	-	-	-		

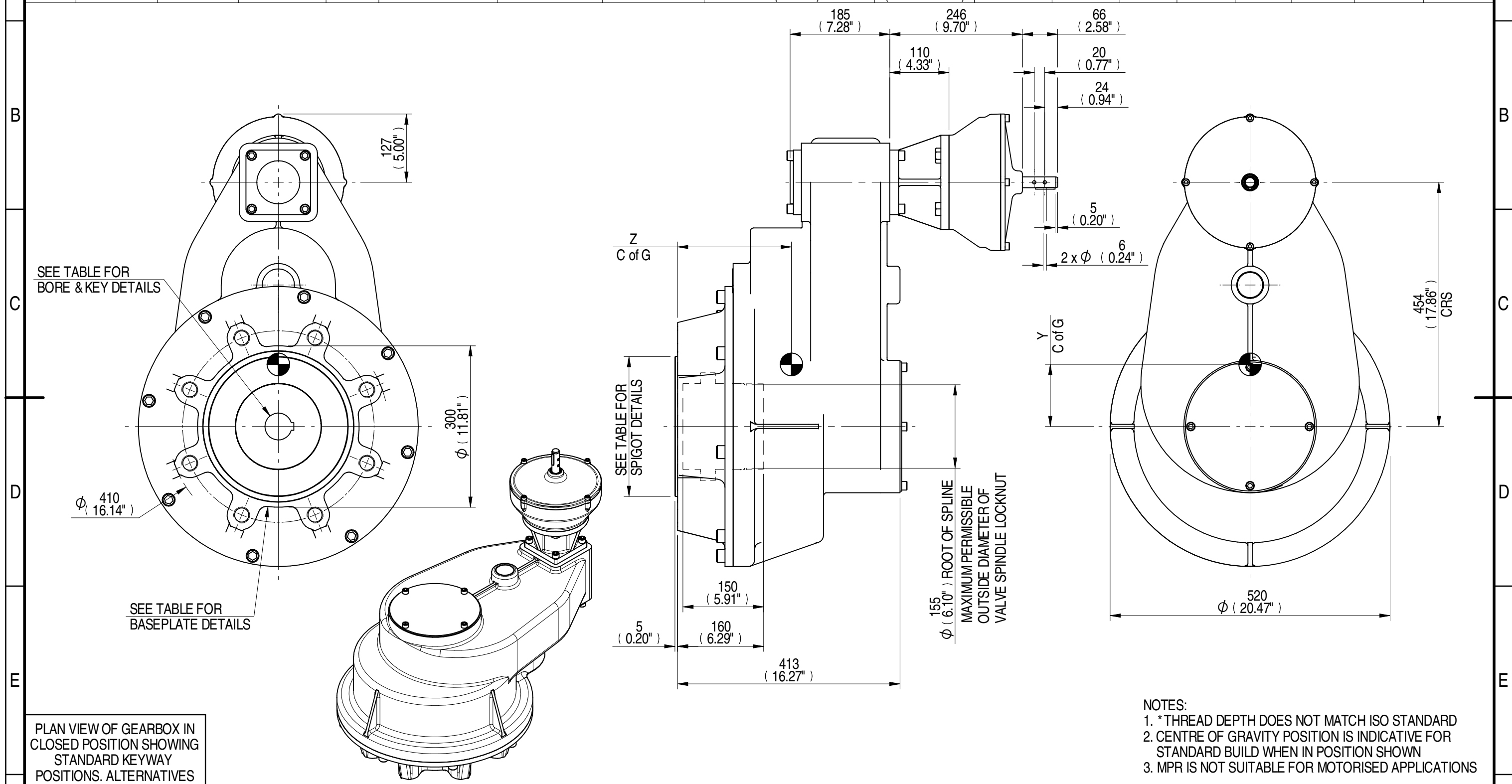

- NOTES:
- * THREAD DEPTH DOES NOT MATCH ISO STANDARD
 - CENTRE OF GRAVITY POSITION IS INDICATIVE FOR STANDARD BUILD WHEN IN POSITION SHOWN
 - MPR IS NOT SUITABLE FOR MOTORISED APPLICATIONS

PLAN VIEW OF GEARBOX IN CLOSED POSITION SHOWING STANDARD KEYWAY POSITIONS. ALTERNATIVES AVAILABLE ON REQUEST

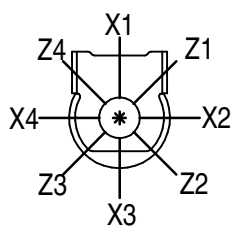

DESCRIPTION	TORQUE	CENTRE OF GRAVITY
151.9 RATIO	116.20 M.A.	297.14 WEIGHT
	15917 MAX OUTPUT	137 MAX INPUT
		0 X
		115 Y
		212 Z

AS PART OF CONTINUOUS PRODUCT DEVELOPMENT, ALL DETAILS SUBJECT TO CHANGE WITHOUT PRIOR NOTICE. FOR UP TO DATE DETAILS PLEASE VISIT www.rotork.com

rotork Gears
LEEDS - UK
www.rotork.com

This drawing is confidential and is the property of Rotork Gears and must not be reproduced either wholly or partly. All rights in respect of patents, designs and copyrights are reserved. © 2015

Document Type	PUBLICITY	Mass	297.14 kg	Title	HOS15 15:1 MPR10 GEARBOX STANDARD INPUT REDUCER, F35/FA35 OUTPUT.	
Created	E CHANG	10/03/2015	Dimensions in mm	Drawing Number	PUB-HOS15MPR10-151.9-MAN-F35	
Checked	J DICKINSON	17/03/2015	Scale	1:7	Iss.	01
Approved				Sheet	1	of 1
				Size	A3	