

E-FLANGE INPUT
ISOMETRIC VIEW
1:8

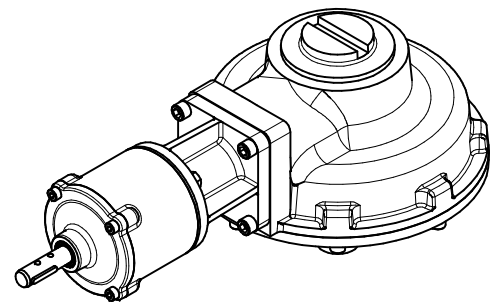

STANDARD INPUT
ISOMETRIC VIEW
1:8

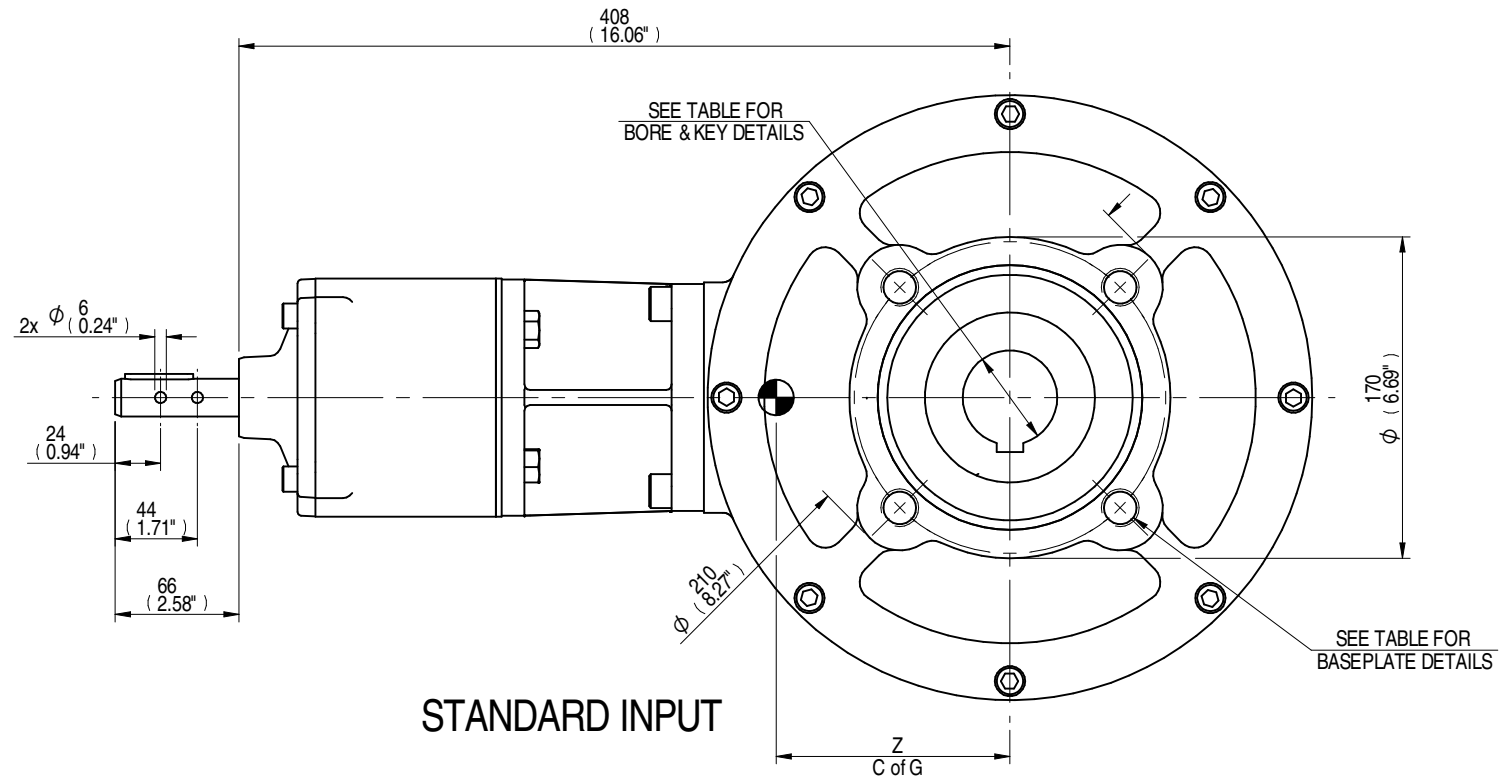

NOTE:
MPR IS NOT SUITABLE FOR MOTORISED APPLICATIONS.

COMMON INPUT DETAILS		E-FLANGE INPUT DETAILS			
SHAFT DIA.	KEY DETAILS	FLANGE O/DIA.	RECESS DIA.	RECESS DEPTH	HOLE DETAILS (45° OFF CENTRES)
Ø19.98-0.05	6x6x36	Ø126	Ø70.05+0.05	3	4 HOLES Ø10.5 ON Ø102.0 P.C.
(Ø0.787"-0.002")	(0.24"x0.24"x1.42")	(Ø4.96")	(Ø2.758"+0.002")	(0.12")	4 HOLES Ø0.41" ON Ø4.02" P.C.

MOUNTING HOLES - BOLT CIRCLE (OFF CENTRES)		
STANDARD	SPIGOT DIAMETER	HOLE DETAILS (45° OFF CENTRES)
ISO F16	Ø129.95-0.05 (Ø5.116"-0.002")	4 HOLES M20X25 (0.98") DEEP ON Ø165.0 (Ø6.50") P.C.
FA16	Ø126.87-0.25 (Ø4.995"-0.010")	4 HOLES 3/4"UNCX25 (0.98") DEEP ON Ø165.1 (Ø6.50") P.C.

MAX BORE SQ KEY			MAX BORE RECTANGULAR KEY		MAX. STEM SCREW ACCEPTANCE DIA.
STD	BORE	KEY	BORE	KEY	
BS4235	-	-	68.0	20x12	73 (2.875")
BS46	2.500"	5/8" SQ	2.625"	3/4" x 1/2"	
ANSI B17.1	2.500"	5/8" SQ	2.625"	5/8" x 7/16"	

DESCRIPTION		TORQUE			C of G		
MPR	RATIO	OUTPUT	INPUT	MA	X	Y	Z
MPR4	25.1:1	2033 Nm	112 Nm	18.1	0	33	81
MPR6	24:1	2376 Nm	137 Nm	17.3	0	33	83

AS PART OF CONTINUOUS PRODUCT DEVELOPMENT, ALL DETAILS SUBJECT TO CHANGE WITHOUT PRIOR NOTICE. FOR UP TO DATE DETAILS PLEASE VISIT www.rotork.com

 LEEDS - UK www.rotork.com	This drawing is confidential and is the property of Rotork Gears and must not be reproduced either wholly or partly. All rights in respect of patents, designs and copyrights are reserved. © 2014	Document type PUBLICITY Mass 54.81 kg Dimensions in mm Scale 1:4	Title HOB8 GEARBOX MPR4 AND 6 MANUAL INPUT REDUCER F16/FA16 OUTPUT
	Created J. DICKINSON 22/04/2014 Checked T. WITAMORE 14/05/2014 Approved -	Drawing Number PUB-HOB8MPR46-F16	Rev A
	Sheet 1 of 1 Size A3		

Rev	CN	Revised	Approved	Date	Change Description
A	-	-	-	22/04/2014	FIRST ISSUE