

1	2		3		4			5		6		7		8
A	KEYWAY MACHINING (1 OR 2 KEYS AT 180°)					STEM ACCEPTANCE IN ACCORDANCE TO STANDARD			INPUT DETAILS		MOUNTING HOLES - BOLT CIRCLE (OFF CENTRES)			
	STANDARD	SQ KEY MAX BORE	SQ KEY SIZE	RECT. KEY MAX	RECT. KEY SIZE	MAX SCREW	MAX SQ BORE	MAX SLOT SIZE	SHAFT DIA.	KEY DETAILS	ISO 5211 / MSS	HOLE DETAILS (OFF CENTRES)		SPIGOT DIAMETER
	BS4235	1.500"	□3/8"	40	12 x 8	40 (1.57")	□28 (1.10")	40 x 28AF (1.57" x 1.10"AF)	Ø20-0.10 (0.787"-0.004")	6x6x36 (0.24"x0.24"x1.42")	F10	4xM10x15 (0.59") DEEP ON Ø102 (Ø4.02") P.C.		Ø69.95-0.05 (Ø2.75"-0.02")
	BS46			7/16" x 5/16"	3/8" x 1/4"									
	ANSI B17.1 DIN 6885			40	12 x 8									
	KEYWAY MACHINING (4, 3 OR 2 KEYS AT 90°)					40 (1.57")	□28 (1.10")	40 x 28AF (1.57" x 1.10"AF)	Ø20-0.10 (0.787"-0.004")	6x6x36 (0.24"x0.24"x1.42")	FA10	4x3/8-16"UNCx15 (0.59") DEEP ON Ø101.6 (Ø4.00") P.C.		Ø58.70-0.05 (Ø2.31"-0.02")
	STANDARD	SQ KEY MAX BORE	SQ KEY SIZE	RECT. KEY MAX	RECT. KEY SIZE									
	BS4235	1.250"	□5/16"	32	12 x 8									
	BS46			3/8" x 1/4"										
	ANSI B17.1 DIN 6885			32	12 x 8									

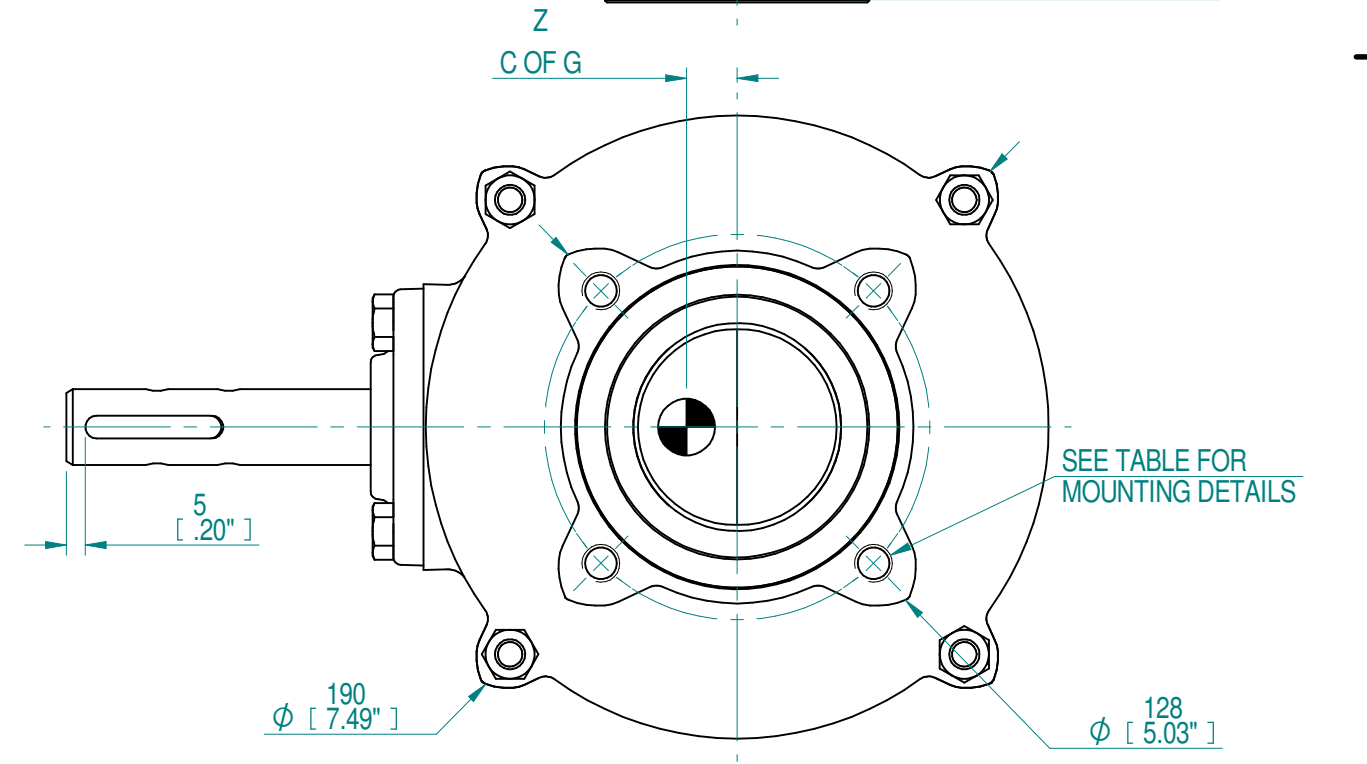

PLAN VIEW OF GEARBOX IN CLOSED POSITION SHOWING STANDARD KEYWAY POSITIONS. ALTERNATIVES AVAILABLE ON REQUEST

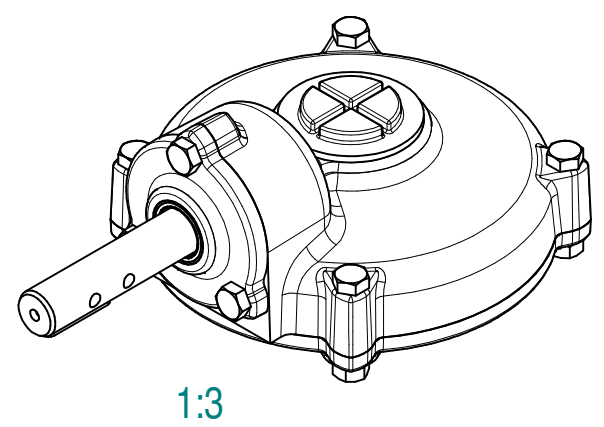
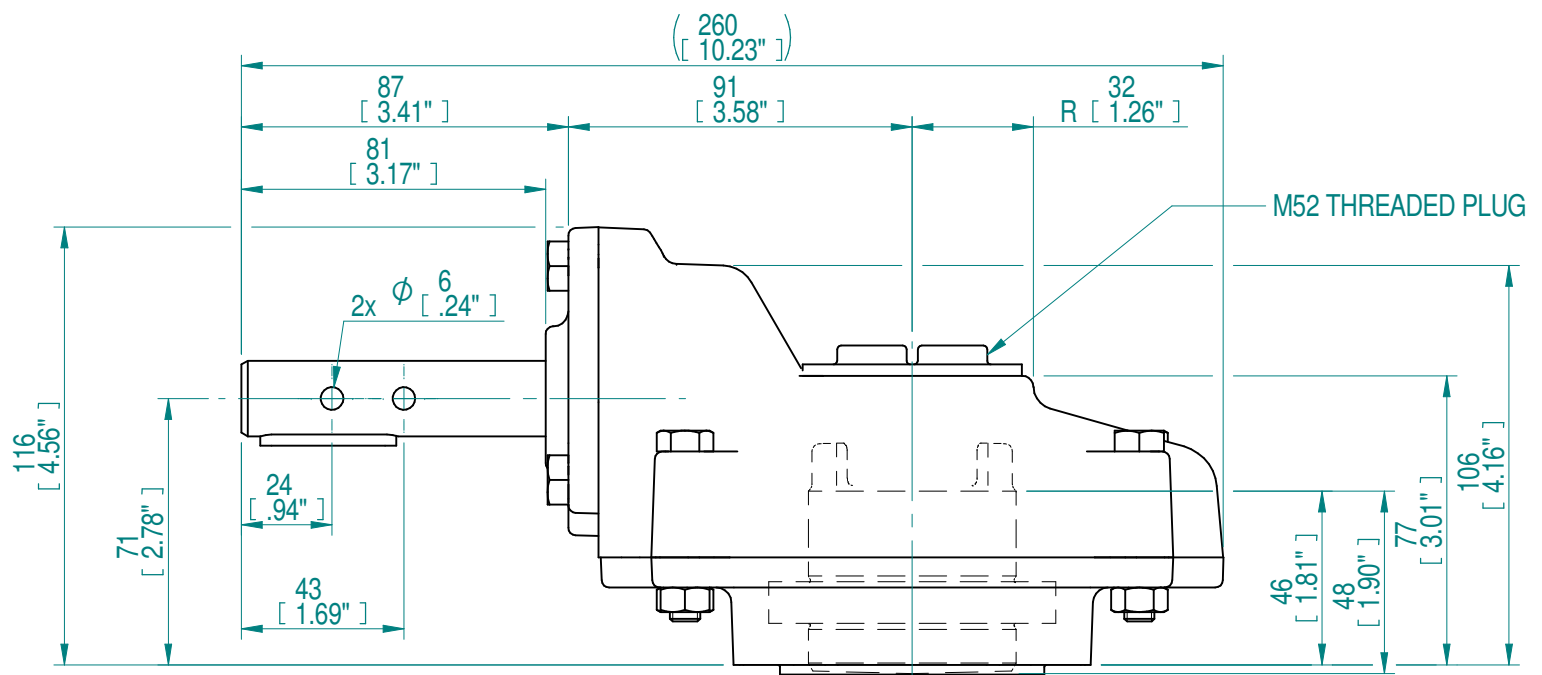
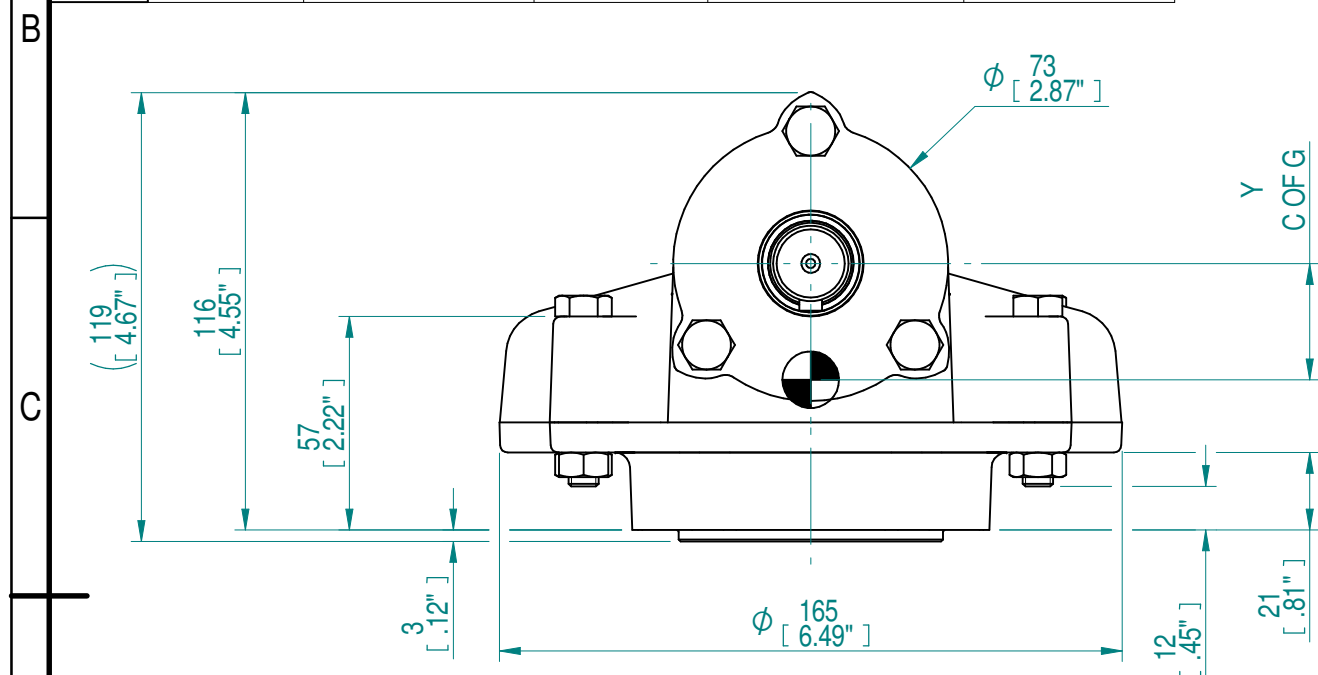
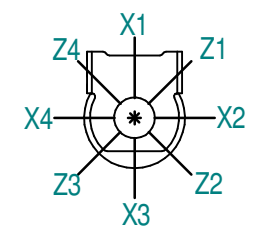

NOTES:
1. CENTRE OF GRAVITY POSITION IS INDICATIVE FOR STANDARD BUILD WHEN IN POSITION SHOWN

3	N/A	2.6	7.4Kg	270Nm	108Nm	0	31	13
RATIO	TURNS TO CLOSE	M.A. ±15%	WEIGHT	MAX OUTPUT	MAX INPUT	X	Y	Z
DESCRIPTION			TORQUE		CENTRE OF GRAVITY			

AS PART OF CONTINUOUS PRODUCT DEVELOPMENT, ALL DETAILS SUBJECT TO CHANGE WITHOUT PRIOR NOTICE. FOR UP TO DATE DETAILS PLEASE VISIT www.rotork.com

<p>LEEDS - UK www.rotork.com</p>	<p>This drawing is confidential and is the property of Rotork Gears and must not be reproduced either wholly or partly. All rights in respect of patents, designs and copyrights are reserved. ©2016</p>	<p>Document Type PUBLICITY</p> <p>Dimensions in mm</p>	<p>Title HOB3 PUBLICITY ASSEMBLY - F10/FA10 OUTPUT HOB3</p>
	<p>Drawing Number PUB-HOB3-F10_FA10</p>	<p>Iss. 0-0</p>	<p>Sheet 1 of 1 Size A3</p>