

NOTES:

1. MECHANICAL STOPS, ADJUSTABLE
2. GEAR ENGAGEMENT LEVER
3. DECLUTCH PULL-PIN
4. MOUNTING BOLTS TO 50 ACTUATOR
5. EST. WT. 108.86 kg (240 LB.)
6. ACTUATOR MAY BE REMOVED FROM AUTOMATED VALVE WHILE GEAR REMAINS ATTACHED TO OPERATE THE VALVE OR DAMPER.
7. AVAILABLE WITH ISO 5211 VALVE-SIDE MOUNT FLANGE AND FEMALE DRIVE - CONSULT ROTORK

196 [7.72 in] 55.4 [2.18 in]

SEE NOTE : 4

SEE NOTE : 3

SEE NOTE : 2

68 [2.68 in]

Ø 300 [11.81 in]

155 [6.10 in]

q 108 [4.25 in]

q 40.89 [1.61 in]

4X 7/8-9UNC-2B
TAPPED ~ 24 [0.944 in]
ON 152.74 [6.01 in] BOLT CIRCLE
STRADDLE CENTER LINE

ACTUATOR VIEW

SIDE VIEW

VALVE SIDE MOUNTING VIEW

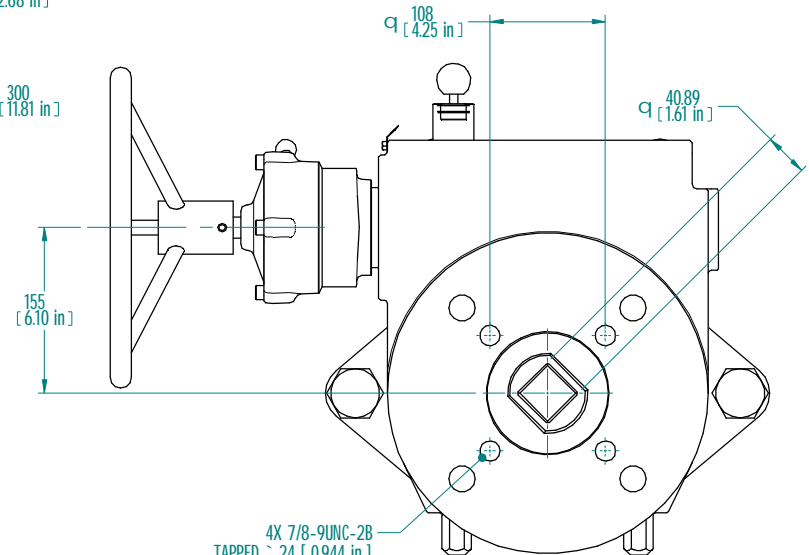
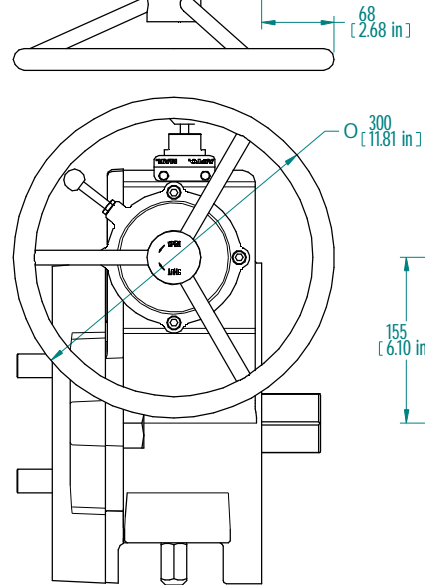
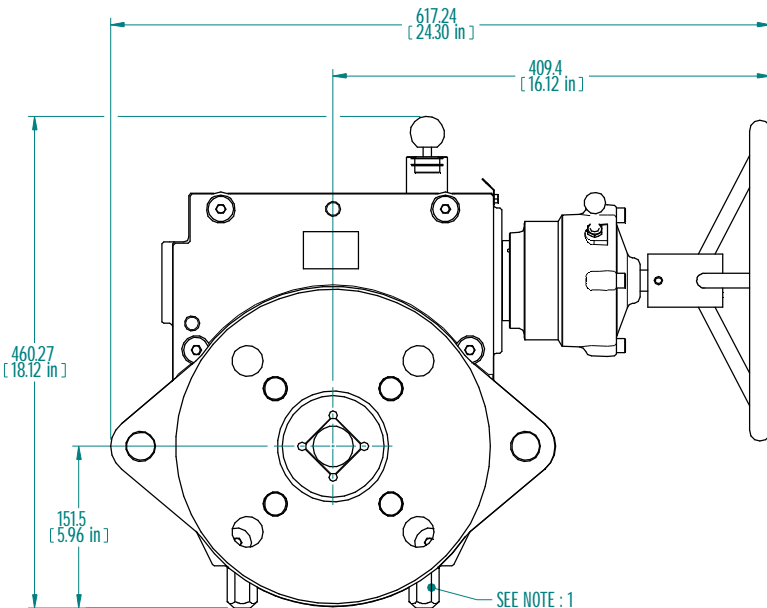

rotork® This drawing is confidential and is the property of Rotork Dallas Inc. and must not be reproduced either wholly or partly. All rights in respect of patents, designs and copyrights are reserved. © 2015

Dallas, Texas - USA
www.rotork.com

Document type		GENERAL ARRANGEMENT		Title	
		Dimensions in mm		KT-50-HWMO	
		Scale 1:5		IMPERIAL MOUNTING HOLES	
Created	K.SEKAR	12-JUN-2015	Drawing Number		
Checked	S.SUDHR	12-JUN-2015	D000000248		
Approved	K.PRICE	12-JUN-2015	Sheet 1 of 1	Size A3	Rev B

Rev C