

- NOTES:  
 1) MECHANICAL STOPS, ADJUSTABLE  
 2) GEAR ENGAGEMENT LEVER  
 3) DECLUTCH PULL-PIN  
 4) MOUNTING BOLTS TO K-1 ACTUATOR / SR  
 5) EST. WT. 6.05 kg (13.34 LB..)  
 6) ACTUATOR MAY BE REMOVED FROM AUTOMATED VALVE WHILE GEAR REMAINS ATTACHED TO OPERATE THE VALVE OR DAMPER.  
 7) AVAILABLE WITH ISO 5211 VALVE-SIDE MOUNT FLANGE AND FEMALE DRIVE - CONSULT K-TORK.

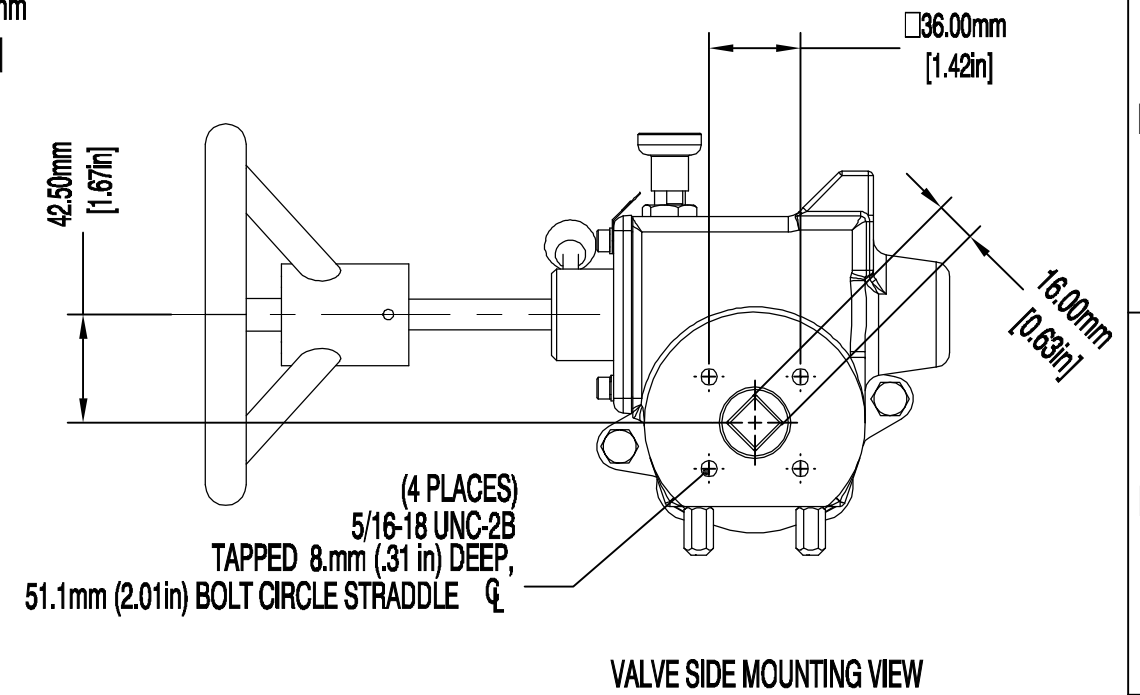
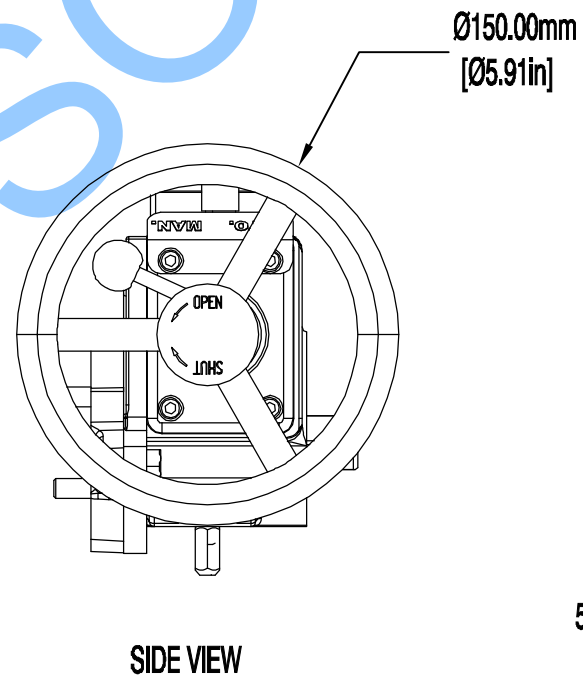
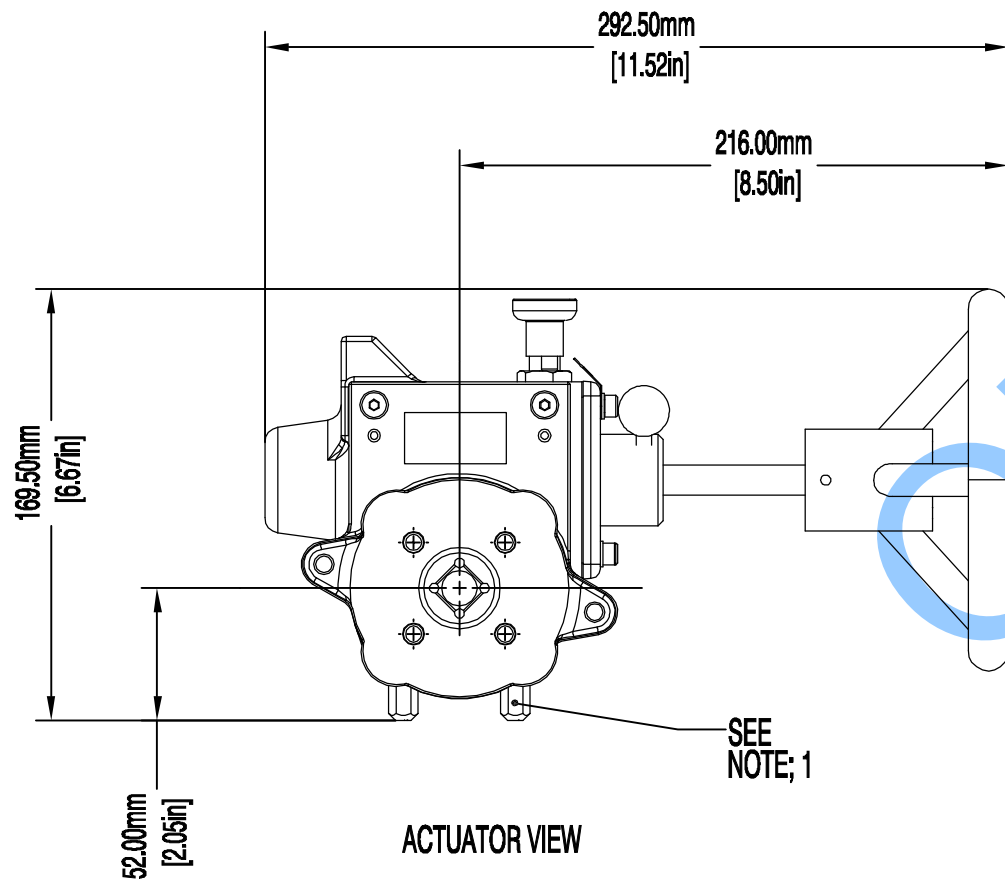
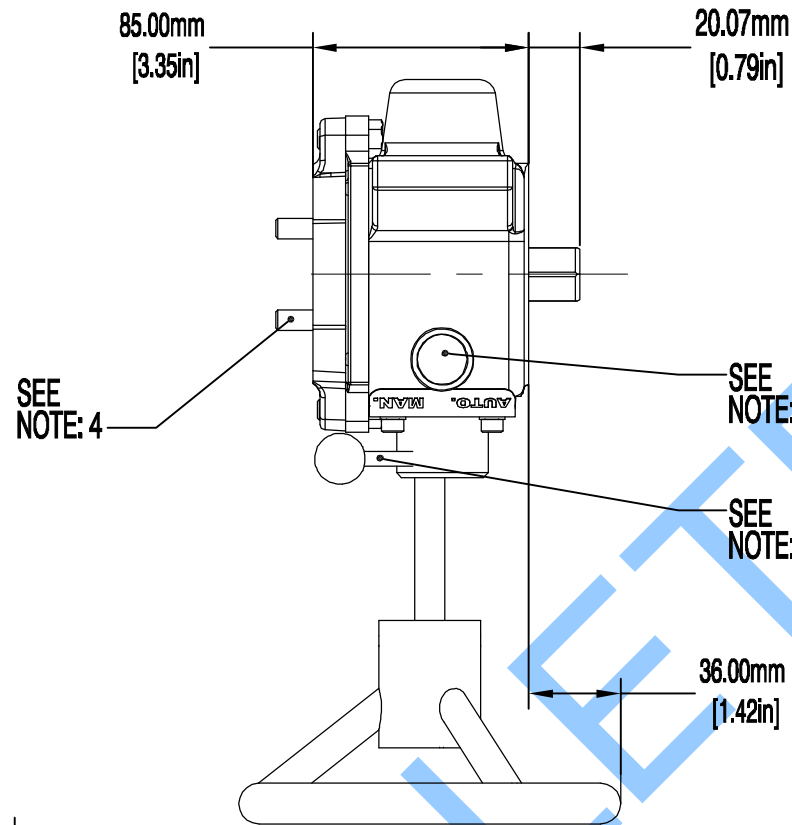
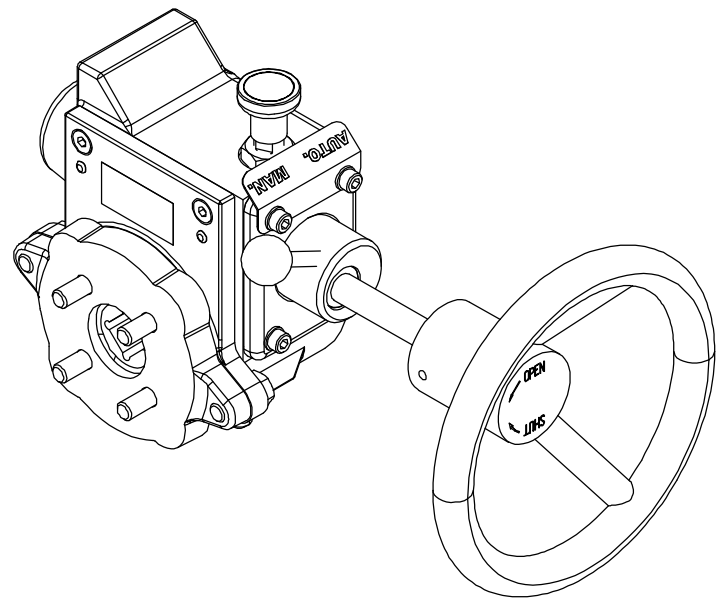

**K-TORK**  
 ACTUATORS + CONTROLS  
 Texas - USA  
 www.rotork.com

This drawing is confidential and is the property of Rotork Dallas Inc. and must not be reproduced either wholly or partly. All rights in respect of patents, designs and copyrights are reserved. © 2015

Document type	DETAIL DRAWING	
	Dimensions in mm	
	Scale 1:1	
Created	S.DINESH	30-JAN-2015
Checked	S.SUDHIR	30-JAN-2015
Approved	K.PRICE	30-JAN-2015

Title		K-1-HWMO, IMPERIAL MOUNTING HOLES	
Drawing Number		D000000244	
Rev	0	Sheet	1 of 1
Size		A3	

Rev B