

INSTALLATION, OPERATING AND MAINTENANCE INSTRUCTIONS FOR FAIRCHILD MODEL 24 SNAP ACTING RELAY

GENERAL INFORMATION

The Model 24 Snap Acting Relay can operate by means of one or two signals to control flow. A normally open or normally closed option is available.

Specifications Model 24

Capacity 4 SCFM (23.8 m³/HR)
(100 psig [7.0 BAR] (700 kPa) supply)

Exhaust capacity 4 SCFM (23.8 m³/HR)
(100 psig [7.0 BAR] (700 kPa) drop)

Maximum supply pressure 120 psig
[8.0 BAR] (800 kPa)

Minimum supply pressure .. 10 psig [.7 BAR] (70 kPa)
(Use separate supply option
if inlet pressure is less than
10 psig [.7 BAR] (70 kPa))

Signal range 2" (5.08 cm)
H₂O - 120 psig [8.0 BAR] (800 kPa)

Repeatability ±0.2" (.5 cm) W.C.

Air Consumption less than 0.015 SCFM
(.03 m³/HR) for 100 psig
[7.0 BAR] (700 kPa) inlet

CV Rating 0.23

Minimum switching differential 0.1 psig
[.007 BAR] (.7 kPa)

PRINCIPLES OF OPERATION

Assume that adjusting screw (40) Figure 1 has been backed out; initially so that the spring K1 (37) is not exerting pressure on piston diaphragm (46). Supply air entering the inlet port will flow through orifice (11) to the top of control diaphragm (4) and through nozzle (part of nozzle housing and assembly (3). Spring K2 (16) exerts pressure against the pilot diaphragm (8) moving ball which presses against and closes the nozzle. With the nozzle closed, pressure builds up over control diaphragm (4) causing pintle (31) (32) to move down against the force of spring (27), opening a path to the outlet port. Spring K1 (37) which exerts force against piston diaphragm (46) is adjusted so that the nozzle (8) again opens, decreasing pressure over control diaphragm (4). Spring (27) will force pin:le (31) (32) to move up and close the path to the outlet port.

A pneumatic signal at A will generate a force on the underside of diaphragm (43) opposing force exerted on the diaphragm by spring K1 (37). As the signal pressure increases, it will reach or surpass set point, initiating snap action.

A pneumatic signal inserted at B can be used in conjunction with or in place of K1 since it will exert pressure on the top of diaphragm (43). Operating

principal for the normally open option is essentially the same. See catalog sheet for typical applications.

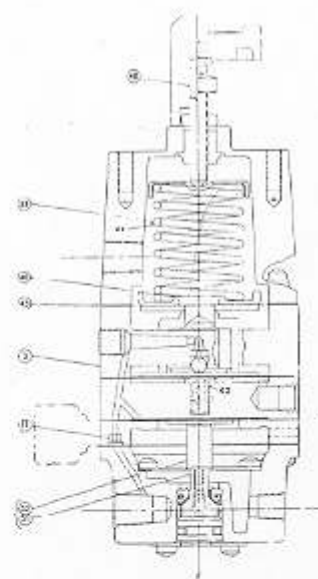

Figure 1

INSTALLATION

The relay (Figure 2) may be pipe mounted or mounted with a bracket EB-39921 in any position. Clean all lines to remove dirt and scale before installation is made. When installing pipe or tube fitting into the unit, it is preferred to use teflon tape as a sealant, but if pipe compound is used care must be taken to prevent the introduction of any compound into the relay. It is preferable to start with

the third thread back and work away from the end of the line to avoid the possibility of getting compound into the relay. The table below shows inlet and outlet fittings for the various catalog items. Inlet and outlet connections are labeled and fittings should be tightened securely.

NOTE: Instrument air should be used.

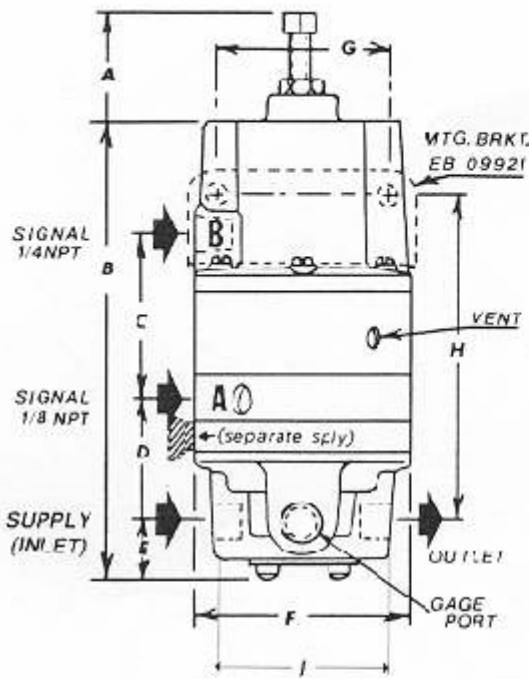

Figure 2

Catalog Number		Range			Inlet & Outlet	Change in Signal To Operate
Norm Open	Norm Closed	(psig)	[BAR]	(kPa)		
243122	243222	2" W.C.-10	2" W.C. -	5.08 cm - 70	1/4"	0.2" W.C.
243123	243223	2" W.C.-10	2" W.C. - .7	5.08 cm - 70	3/8"	0.2" W.C.
243132	243232	.5-30	.035-2.0	3.5-200	1/4"	0.1 psig
243133	243233	.5-30	.035-2.0	3.5-200	3/8"	0.1 psig
243142	243242	1.0-60	.07-4.0	7.0-400	1/4"	0.2 psig
243143	243243	1.0-60	.07-4.0	7.0-400	3/8"	0.2 psig
243162	243262	2.0-120	1.4-8.0	14-800	1/4"	0.5 psig
243163	243263	2.0-120	1.4-8.0	14-800	3/8"	0.5 psig

DIM LETTER	INCHES	MM
A	2.25	57.15
B	0.312	160.3
C	2.187	55.16
D	1.718	43.66
E	.75	19.5
F	3.0	76.20
G	2.25	57.15
H	4.375	111.13
I	2.656	67.48

ADJUSTMENT

For normal operation the following procedures should be performed:

1. Back out adjusting screw until spring K1 is fully extended.

2. Monitor outlet port to assure that supply air is being obtained at outlet port.

3. Adjust screw clockwise until no air is obtained at outlet port.

OPERATION

If signals A and B are equal the valve will be in its normal position. To switch to opposite position, increase signal A or decrease signal B.

MAINTENANCE

Before disassembling the relay for cleaning or removal of foreign matter, shut off valve upstream of the relay. The adjusting screw should be lubricated with Molycote type "G" grease.

TROUBLE SHOOTING

PROBLEM

Requires excessive signal to trip relay

CHECK

Nozzle check valve seat for dirt
Pintle travel
Balance spring

REPAIR PARTS LIST

The Model 24 should be returned to the factory for repair.

LEGAL NOTICE:

The information set forth in the foregoing Installation, Operation and Maintenance Instructions shall not be modified or amended in any respect without prior written consent of Fairchild Industrial Products Company. In addition, the information set forth herein shall be furnished with each product sold incorporating Fairchild's unit as a component thereof.



ISO 9001:2000
FM NO. 25571

www.fairchildproducts.com

IS- 3000024
Litho in USA
Rev. G 12/96