

FAIRCHILD MODEL 4500ABP BACK PRESSURE RELAY

Installation, Operation, and Maintenance Instructions

Introduction

Fairchild's Model 4500ABP Back Pressure Relay is designed to enable automation of the back pressure regulator function. For the Model 4500ABP, the back pressure set point is determined by the pressure applied to its signal port and can be controlled by devices such as electro-pneumatic transducers, pressure regulators, solenoid valves, and other pressures present in the control system. In addition, the Model 4500ABP is available with various ratio variations enabling the back pressure set point to be controlled by a signal pressure lower than the back pressure value.



Features

- High accuracy pressure regulation.
 - Ideal for precision applications
- Bubble tight valve sealing.
 - No consumption when system is below set point.
- Damped control chamber.
 - Provides stable, noise free operation
- Three port sizes -3/8", & 1/2" & 3/4"
 - To match system requirements
- Optional fluorocarbon elastomers
 - Provides wide range of media and environmental compatibility

Table 1. Specifications & Limits

Parameter	Value
Maximum Inlet Pressure	250 psig 17Bar 1700 kPa
Maximum Outlet Pressure	250 psig 17Bar 1700 kPa
Maximum Signal Pressure	150 psig 10 Bar 1000 kPa
Ambient Temperature Limits	-40° to +180°F -40° to +80°C
Maximum Valve Cv	3.0
Weight	1.23 lb 0.56 Kg

FAIRCHILD MODEL 4500ABP BACK PRESSURE RELAY

Installation, Operation, and Maintenance Instructions

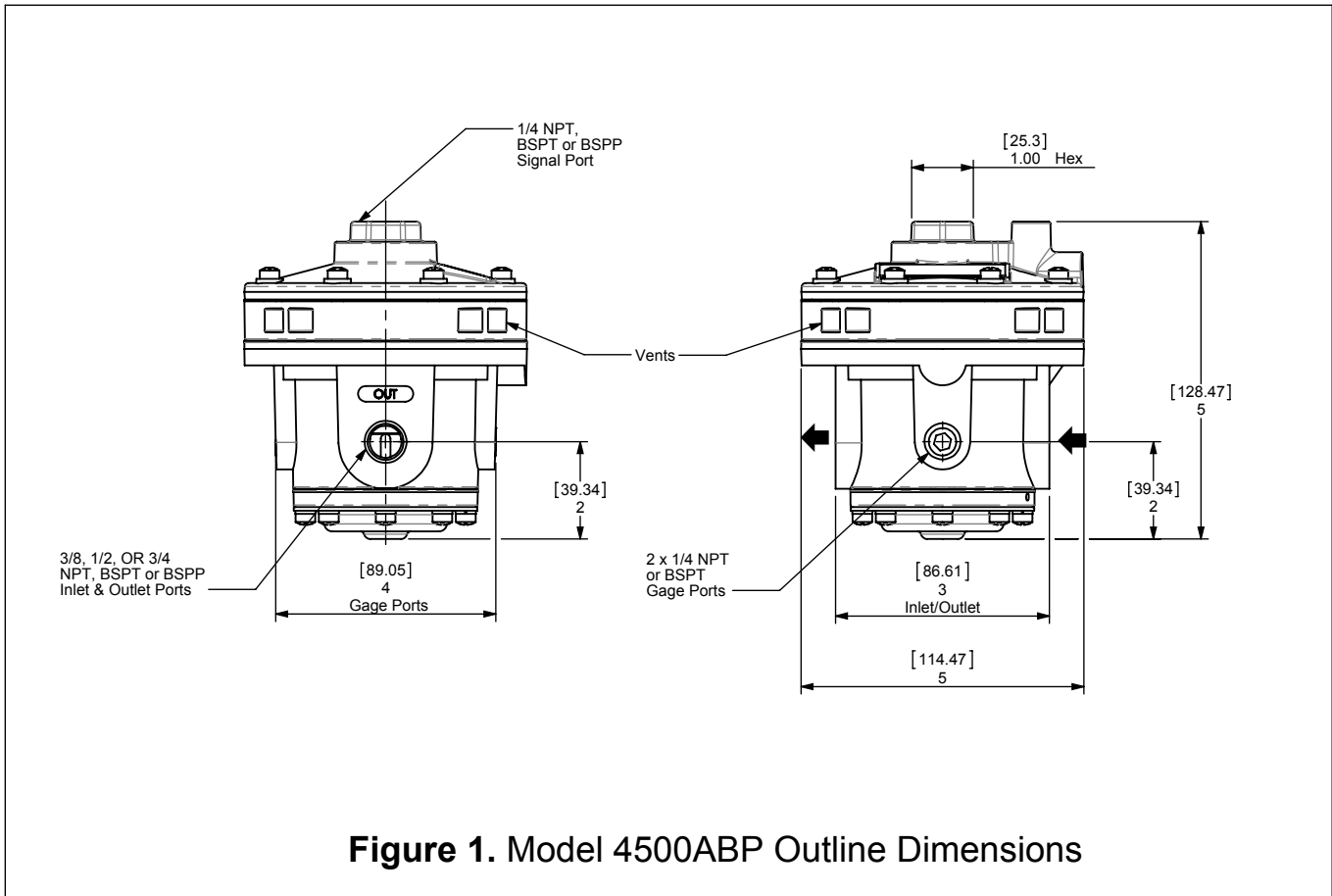

Figure 1. Model 4500ABP Outline Dimensions

Table 2. Materials of Construction

Body	Die Cast Aluminum
Relief Valve	Neoprene on Aluminum Fluorocarbon on Aluminum (Optional)
Seal Plate	Zinc Plated Steel
Valve Seat	Brass
Diaphragms	Nitrile on Polyester Fluorocarbon on Polyester (Optional)
Seals	Nitrile Fluorocarbon (Optional)
Springs	Stainless Steel
Fasteners	Zinc Plated Steel

Installation

You can mount the relay in any position without affecting its operation.

Clean all pipelines to remove dirt and scale before installation.

Apply a minimum amount of pipe compound to the male threads of the fitting only. **Do Not use Teflon tape as a sealant.** Start with the third thread back and work away from the end of the fitting to avoid contaminating the relay. Install the relay in the air line.

The Inlet and Outlet are labeled "IN" and "OUT". Tighten all connections securely. Avoid undersized fittings that will limit the flow through the relay. For more information, see Figure 1.

FAIRCHILD MODEL 4500ABP BACK PRESSURE RELAY

Installation, Operation, and Maintenance Instructions

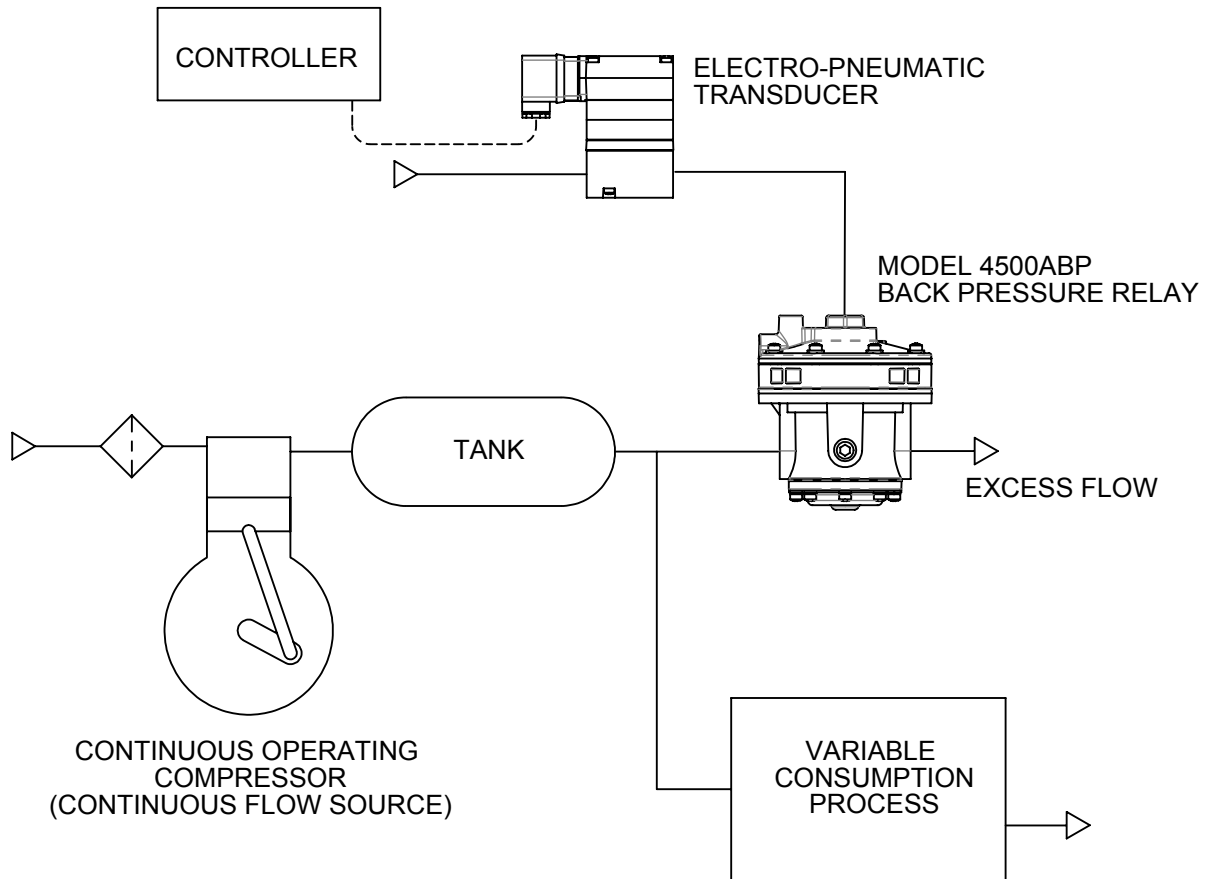

Figure 2. VARIABLE PRESSURE CONTINUOUS FLOW SYSTEM

Back pressure regulation is typically used in systems with constant flow air pressure sources. A back pressure relay is useful in systems where the back pressure control must be automated. Automation is achieved by employing a pressure transducer connected to the signal port of the back pressure relay. The back pressure relay can also be used to mirror the pressure in another isolated system by porting the isolated system pressure to the signal port of the back pressure relay.

MAINTENANCE

WARNING Shutting off air supply to the volume booster and adjacent equipment can create dangerous system conditions.

To clean the Model 4500ABP, use the following steps:

1. Shut off system pressure to the relay and carefully relieve the pressure in all connected lines. It is not necessary to remove the relay from the air line.
2. Remove the eight screws from the Bonnet and remove the Bonnet. The Diaphragm Assembly will then extract freely from the Valve Body. For more information, see Figure 4.
3. Wash the Valve Plug with a solvent. Exercise care to prevent damage to diaphragms and valve facings. **Avoid solvents such as acetone, carbon tetrachloride and trichloroethylene.**
4. Remove the 4 screws from the Seal Plate and remove the Seal Plate from the Valve Body Assembly. Remove the four screws from the bottom of the bottom cover.
5. Use a wooden dowel to push the Valve Seat, Screen, and Plug out the bottom of the Valve Body.
6. Wash the Valve Seat with a solvent. Exercise care to prevent damage to valve seating surface. **Avoid solvents such as acetone, carbon tetrachloride and trichloroethylene.**
7. Lubricate the o-rings on the exterior of the Valve Seat. Replace the Valve Seat carefully. Replace the Screen and bottom plug and bottom cover, and screws. For more information, see Figure 4.
8. Install the Seal Plate and four screws. Carefully place the diaphragm assembly over the Seal Plate ensuring the Seal rides smoothly over the Seal Tube.
9. Reinstall the Spacer Ring, Bonnet and eight screws. Tighten the screws securely.

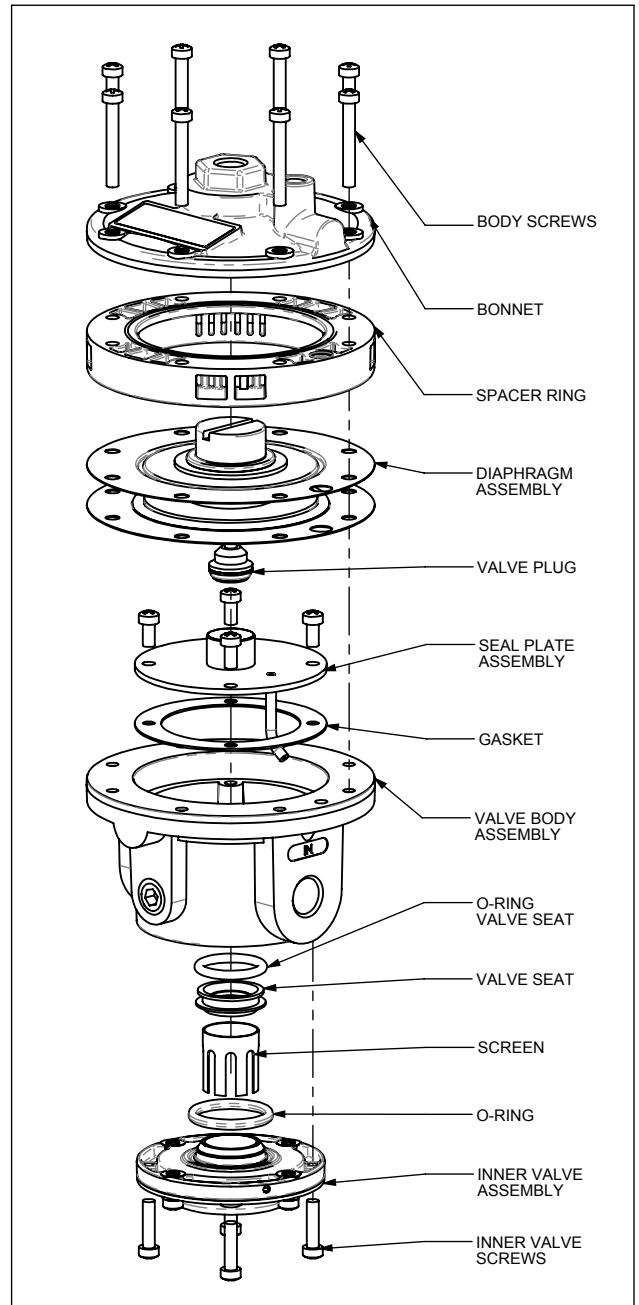

Table 3. Trouble shooting

Problem	Source
External Leakage	Body Bolts
Leakage From Outlet Port	Relief Valve Supply Seat
Leakage from Spacer Vent Holes	Diaphragm Assembly

LEGAL NOTICE:

The information set forth in the foregoing Installation, Operation and Maintenance Instructions shall not be modified or amended in any respect without prior written consent of Fairchild Industrial Products Company. In addition, the information set forth herein shall be furnished with each product sold incorporating Fairchild's unit as a component thereof.



FAIRCHILD INDUSTRIAL PRODUCTS CO.
REGISTERED TO ISO 9001:2008
10002346 QM08

