

INPUT FLANGE DETAILS				MOUNTING HOLES - BOLT CIRCLE (OFF CENTRES)				STEM ACCEPTANCE IN ACCORDANCE TO STANDARD					
INPUT FLANGE	FLANGE O/DIA.	HOLE DETAILS (OFF CENTRES)	KEY DETAILS	ISO 5211 / MSS SP-101 MOUNTING OPTION	HOLE DETAILS (OFF CENTRES)	MAX OUTSIDE DIA. INCLUDING DRILLED HOLES	MIN INSIDE DIA. INCLUDING DRILLED HOLES	BORE MACHINED IN	STANDARD	MIN BORE	RECT. KEY MAX BORE	RECT. KEY SIZE	SQ BORE MAX
-	-	-	-	F10 (FA10)	4x M10* x 13 DEEP ON A Ø102P.C. (4x 3/8"UNC x 0.51" DEEP ON A Ø4"P.C.)	Ø195 (Ø7.68")	Ø79 (Ø3.11")	QUADRANT	DIN 6885	Ø16	Ø60	18 x 11	□ 46
				F12 (FA12)	4x M12* x 16 DEEP ON A Ø125P.C. (4x 1/2"UNC x 0.63" DEEP ON A 4.95"P.C.)				BS46	Ø0.63"	Ø2.3592"	5/8 x 7/16	□ 1.81"
				F14 (FA14)	4x M16* x 18 DEEP ON A Ø140P.C. (4x 5/8"UNC x 0.71" DEEP ON A 5.5"P.C.)				DIN 6885	-	Ø40	12 x 9	□ 36
				F16 (FA16)	4x M20* x 18 DEEP ON A Ø165P.C. (4x 3/4"UNC x 0.71" DEEP ON A 6.5"P.C.)				BS46	-	Ø1.5733"	7/16 x 5/16	□ 1.42"

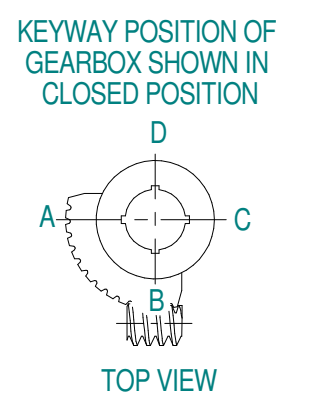
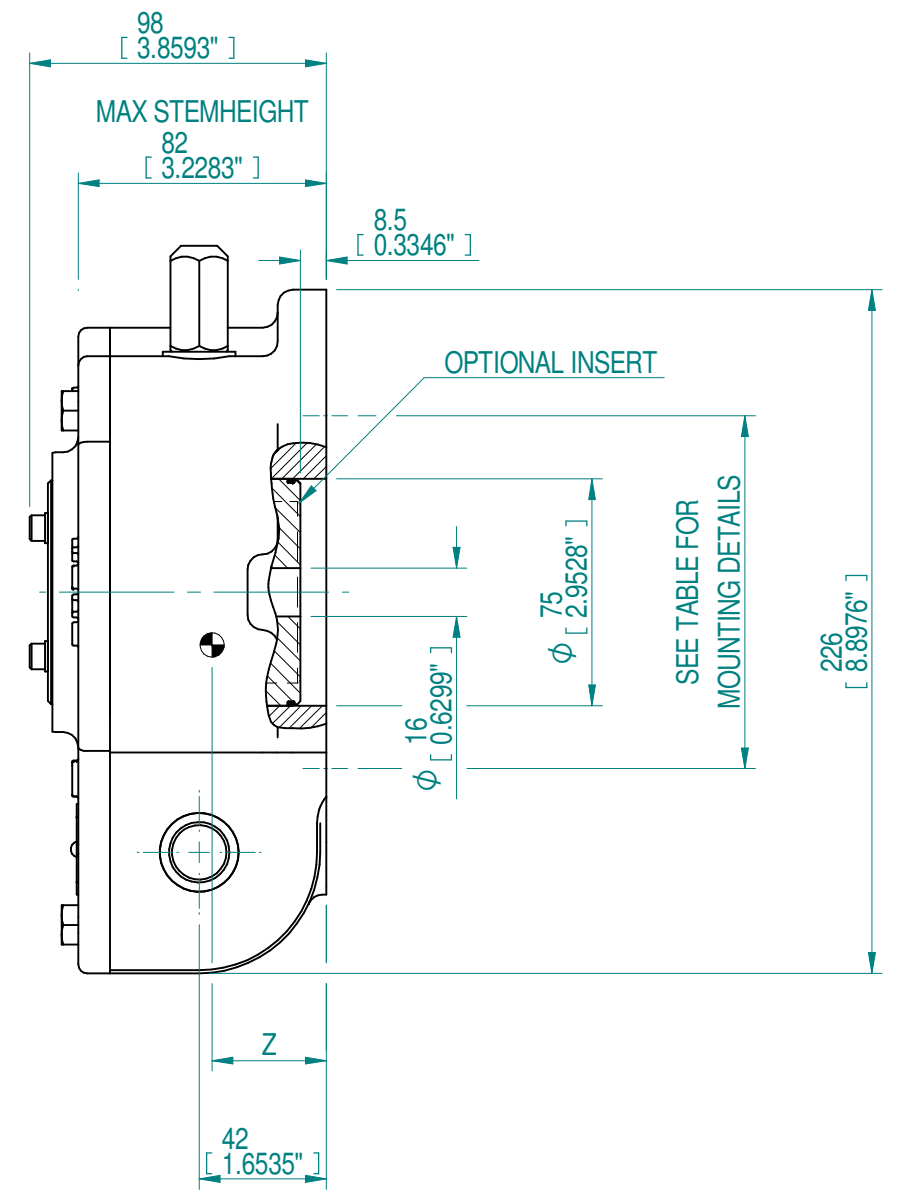
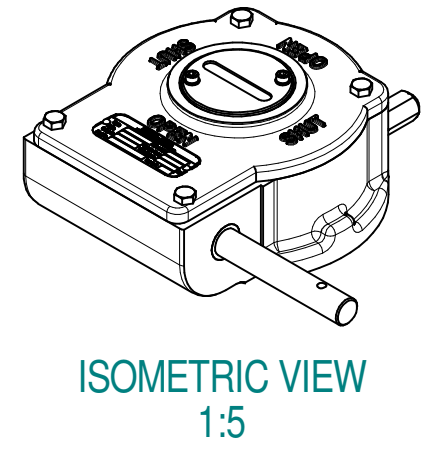
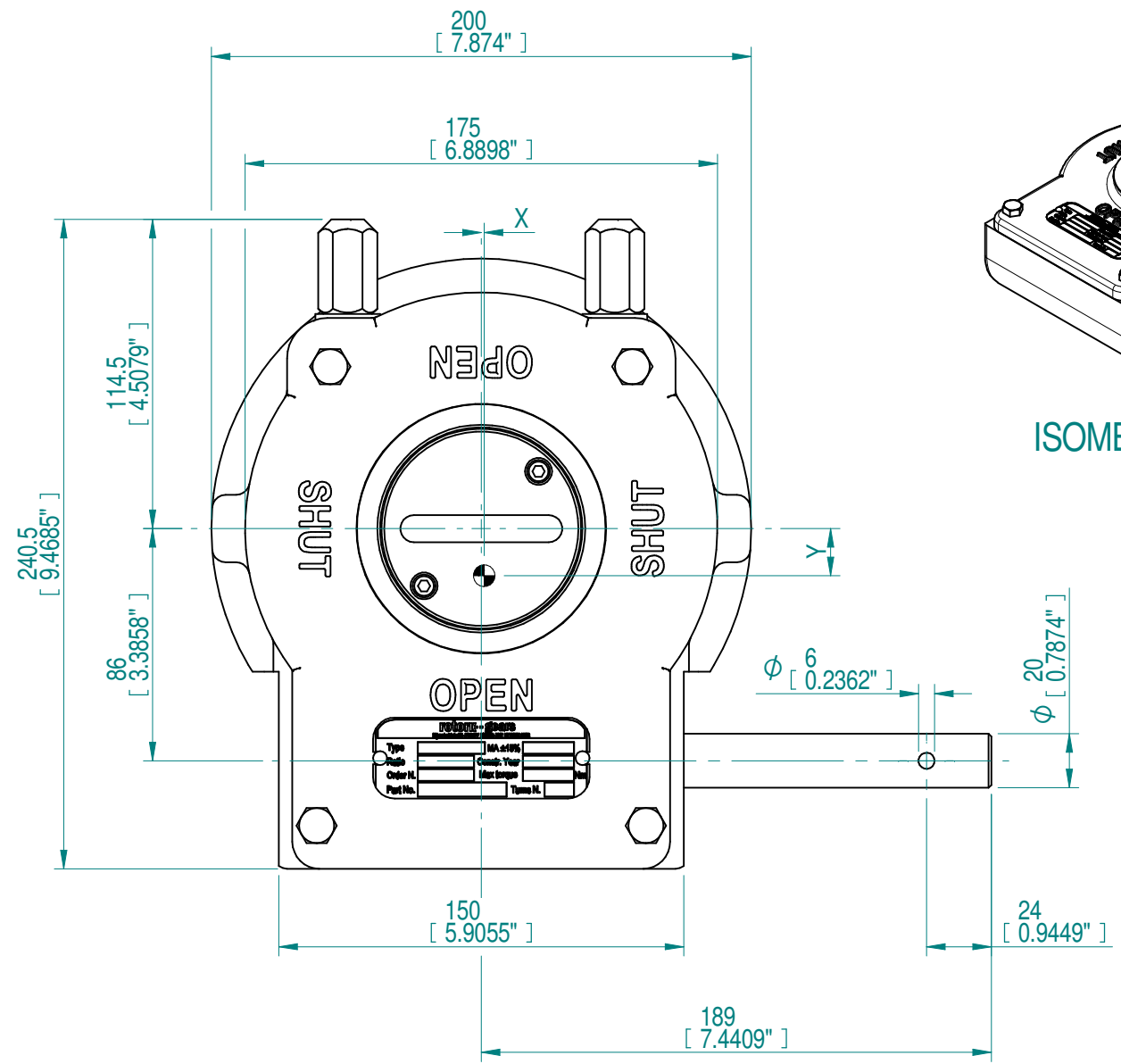

NOTES:
 1. * THREAD DEPTH DOES NOT MATCH ISO STANDARD
 2. CENTRE OF GRAVITY POSITION IS INDICATIVE FOR STANDARD BUILD WHEN IN POSITION SHOWN

DESCRIPTION	TORQUE	CENTRE OF GRAVITY
38 : 1	2000 Nm 17701 lbf.in.	1.1 0.04"
9.5	152 Nm 1341 lbf.in.	17.4 0.69"
13.2 ± 15%	37.8 1.49"	37.8 1.49"
16 kg 35 lbs.		
WEIGHT EXCL. HW		
MAX OUTPUT		
MAX INPUT		
X		
Y		
Z		

AS PART OF CONTINUOUS PRODUCT DEVELOPMENT, ALL DETAILS SUBJECT TO CHANGE WITHOUT PRIOR NOTICE. FOR UP TO DATE DETAILS PLEASE VISIT www.rotork.com

LOSSER - THE NETHERLANDS
www.rotork.com

This drawing is confidential and is the property of Rotork Gears and must not be reproduced either wholly or partly. All rights in respect of patents, designs and copyrights are reserved. © 2018

Document Type	GAD	Title	GEARBOX AB880SS LEFT HANDED WITHOUT BORE AND PC
Created	robbin.goosen	4-7-2018	Drawing Number
Checked	Henk Hoff	4-7-2018	PUB00104
Approved			Sheet 1 of 1 Size A3