

INPUT FLANGE DETAILS				MOUNTING HOLES - BOLT CIRCLE (OFF CENTRES)				STEM ACCEPTANCE IN ACCORDANCE TO STANDARD							
INPUT FLANGE	FLANGE O/DIA.	HOLE DETAILS (OFF CENTRES)	KEY DETAILS	ISO 5211 / MSS SP-101 MOUNTING OPTION	HOLE DETAILS (OFF CENTRES)	MAX OUTSIDE DIA. INCLUDING DRILLED HOLES	MIN INSIDE DIA. INCLUDING DRILLED HOLES	STANDARD	MIN BORE	SQ KEY MAX BORE	SQ KEY SIZE	RECT. KEY MAX BORE	RECT KEY SIZE	SQ BORE MAX	
F10	Ø125 (Ø4.92")	4x Ø11 ON A Ø102P.C. (4x Ø0.42" ON A Ø4.02"P.C.)	6x6x36 (0.24"x0.24"x1.42")	F10 (FA10)	4x M10* x 13 DEEP ON A Ø102P.C. (4x 3/8"UNC x 0.51" DEEP ON A Ø4"P.C.)	Ø195 (Ø7.68")	Ø79 (Ø3.11")	BS4235	-	-	-	-	-	-	-
				F12 (FA12)	4x M12* x 16 DEEP ON A Ø125P.C. (4x 1/2"UNC x 0.63" DEEP ON A 4.95"P.C.)			BS46	-	-	-	-	-	-	
				F14 (FA14)	4x M16* x 18 DEEP ON A Ø140P.C. (4x 5/8"UNC x 0.71" DEEP ON A Ø5.5"P.C.)			ANSI B17.1	Ø0.63"	Ø2.36"	-	-	-	□ 1.81"	
				F16 (FA16)	4x M20* x 18 DEEP ON A Ø165P.C. (4x 3/4"UNC x 0.71" DEEP ON A Ø6.5"P.C.)			DIN 6885	Ø16	Ø60	-	-	-	□ 46	

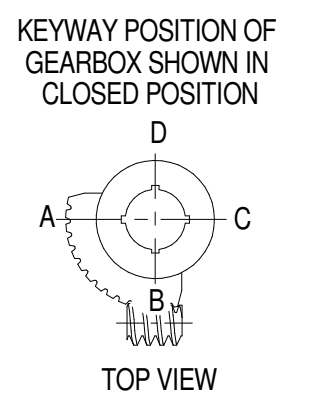
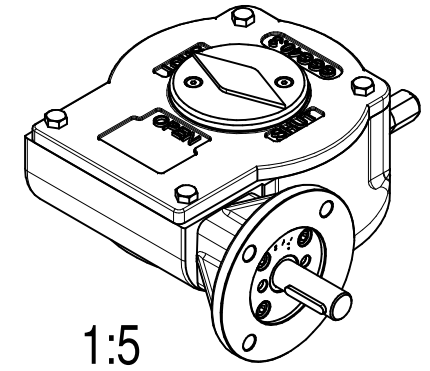
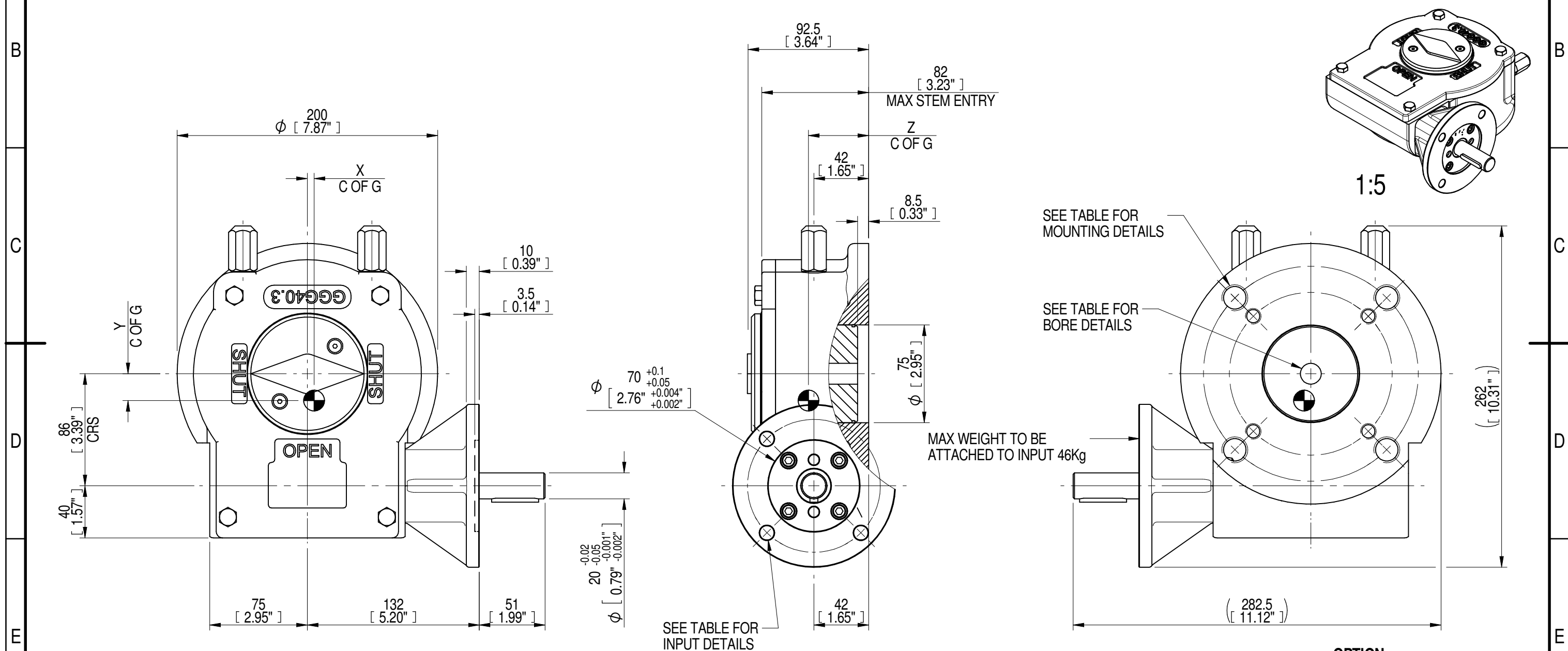

NOTES:  
1. \* THREAD DEPTH DOES NOT MATCH ISO STANDARD

DESCRIPTION	TORQUE	CENTRE OF GRAVITY
RATIO	MAX OUTPUT	X
38:1	1200 Nm	5.2
9.5	10621 lbf.in.	21.2
12 ± 15%	MAX INPUT	45.6
M.A.	885 lbf.in.	1.80"
WEIGHT		
17.2 kg		
37.84 lbs.		

AS PART OF CONTINUOUS PRODUCT DEVELOPMENT, ALL DETAILS SUBJECT TO CHANGE WITHOUT PRIOR NOTICE. FOR UP TO DATE DETAILS PLEASE VISIT [www.rotork.com](http://www.rotork.com)

**rotork** Gears  
LEEDS - UK  
[www.rotork.com](http://www.rotork.com)

This drawing is confidential and is the property of Rotork Gears and must not be reproduced either wholly or partly. All rights in respect of patents, designs and copyrights are reserved. ©2016

Document Type **PUBLICITY**  
Dimensions in mm

Title **GEARBOX AB880 MOTORISED, MARINISED DUTY, LEFT HAND**

Drawing Number **AB880MW LH** Iss. 01

Sheet 1 of 1 Size A3