

INPUT FLANGE DETAILS				MOUNTING HOLES - BOLT CIRCLE (OFF CENTRES)				STEM ACCEPTANCE IN ACCORDANCE TO STANDARD					
INPUT FLANGE	FLANGE O/DIA.	HOLE DETAILS (OFF CENTRES)	KEY DETAILS	ISO 5211 / MSS SP-101 MOUNTING OPTION	HOLE DETAILS (OFF CENTRES)	MAX OUTSIDE DIA. INCLUDING DRILLED HOLES	MIN INSIDE DIA. INCLUDING DRILLED HOLES	BORE MACHINED IN	STANDARD	MIN BORE	RECT. KEY MAX BORE	RECT. KEY SIZE	SQ BORE MAX
-	-	-	-	F10 (FA10)	4x M10* x 13 DEEP ON A Ø102P.C. (4x 3/8"UNC x 0.51" DEEP ON A Ø4"P.C.)	Ø215 (Ø8.46")	Ø89 (Ø3.5")	QUADRANT	DIN 6885	Ø20	Ø65	18 x 11	□ 50
				BS46	Ø0.79"				Ø2.4771"	3/4 x 1/2	□ 1.97"		
				INSERT	DIN 6885			-	Ø40	12 x 9	□ 36		
					BS46			-	Ø1.5733"	7/16 x 5/16	□ 1.42"		

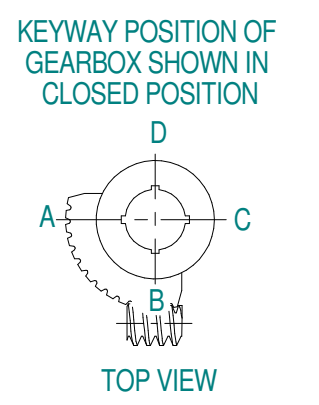
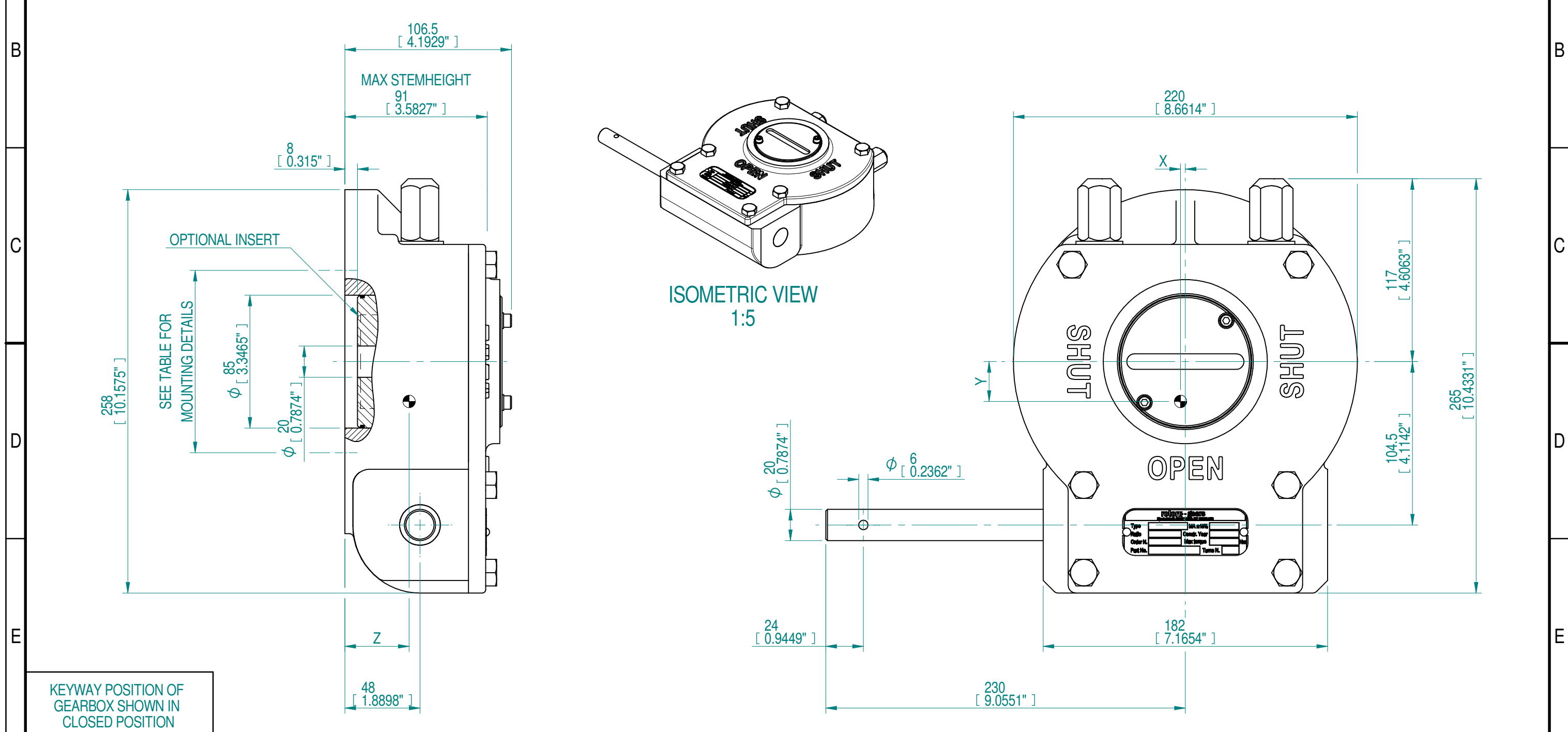

NOTES:  
 1. \* THREAD DEPTH DOES NOT MATCH ISO STANDARD  
 2. CENTRE OF GRAVITY POSITION IS INDICATIVE FOR STANDARD BUILD WHEN IN POSITION SHOWN

DESCRIPTION	TORQUE	CENTRE OF GRAVITY
55 : 1	13.75	19 ± 15%
RATIO	TURNS TO CLOSE	M.A.
	WEIGHT EXCL. HW	MAX OUTPUT
	MAX INPUT	X
	Y	Z

AS PART OF CONTINUOUS PRODUCT DEVELOPMENT, ALL DETAILS SUBJECT TO CHANGE WITHOUT PRIOR NOTICE. FOR UP TO DATE DETAILS PLEASE VISIT [www.rotork.com](http://www.rotork.com)

**rotork** Gears  
 LOSSER - THE NETHERLANDS  
[www.rotork.com](http://www.rotork.com)

This drawing is confidential and is the property of Rotork Gears and must not be reproduced either wholly or partly. All rights in respect of patents, designs and copyrights are reserved. © 2018

Document Type	GAD	Title	GEARBOX AB1250SS RIGHT HANDED WITHOUT BORE AND PC
Created	robbin.goosen	4-7-2018	Drawing Number
Checked	Henk Hoff	4-7-2018	PUB00157
Approved			Sheet 1 of 1 Size A3