

CONDUIT ENTRY HOLE		
Hole	Metric	NPT
A	M32	1 1/4"
B	M25	3/4"
C	M20	3/4"

PARAMETER	VALUE	DESCRIPTION
DRAWING TYPE	A	INSTALLATION DRAWING
ACTUATOR	9	CK(R)A250/500
GEARBOX1	00	NO G.B.1.
GEARBOX2	NO	NO G.B.2
CENTRONIK / TERMINAL	B	3 COND
MECHANISM / MOTOR	S	STD. MECH./SMALL MOT.
HANDWHEEL / REAR / FRONT	0	STD.H.W./STD.REAR./STD.FRNT.
ORIENTATION	0	STD. ORIENT.

NOTE:

- THRUST BASE. PLEASE REFER TO THE TECHNICAL DATA SECTION OF BROCHURE FOR DETAILS OF MAXIMUM AXIAL THRUST RATINGS.
- BASEPLATE DETAILS: F14/FA14.
- DIMENSIONS WITH "" INDICATE COVER REMOVAL ALLOWANCE
- THE INTERFACE PROVIDED FOR MOUNTING THE ACTUATOR OR SECOND STAGE GEARBOX ONTO THE VALVE SHOULD CONFORM TO GOOD ENGINEERING PRACTICES, ENSURING ADEQUATELY TOLERANCED LIMITS FOR PARALLELISM, PERPENDICULARITY AND CONCENTRICITY.
- ROTORC CANNOT BE HELD LIABLE FOR DAMAGE TO OUR EQUIPMENT CAUSED BY EXCESSIVE LOADING FROM COVER TUBES, HANDWHEEL AND HAND LEVER.

CK range	Drawn	TAMIL	14-12-18
	Checked	BHARAT	14-12-18
	Approved	JOSE	14-12-18

Title	DIMENSIONAL DRAWING, CKA250/500 & CKRA250/500, 3 CONDUIT ENTRIES, SMALL MOTOR, STANDARD ORIENTATION.
--------------	--

A4	Doc Number	Ver No	Scale	Sheet No
	A900N0BS00X	1	NTS	1 of 2

This drawing and the information it contains are property of Rotork Controls Limited, and they will not be reproduced or disclosed, in whole or in part, without the prior written consent of Rotork.

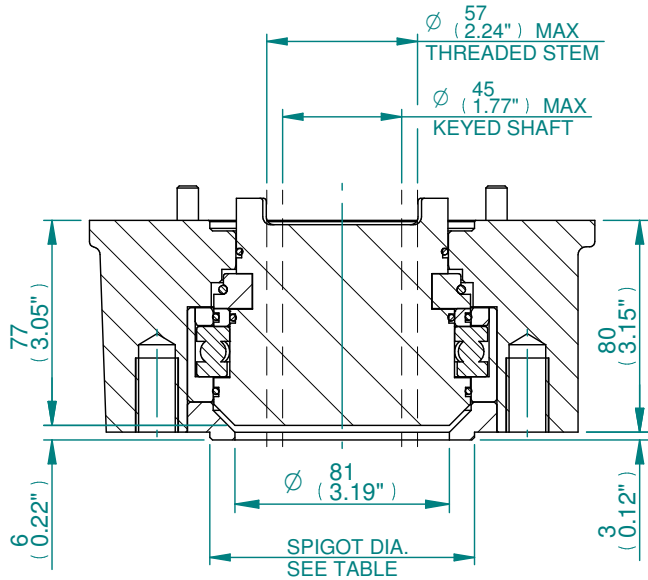

**TYPE "A"
COUPLING DETAILS**

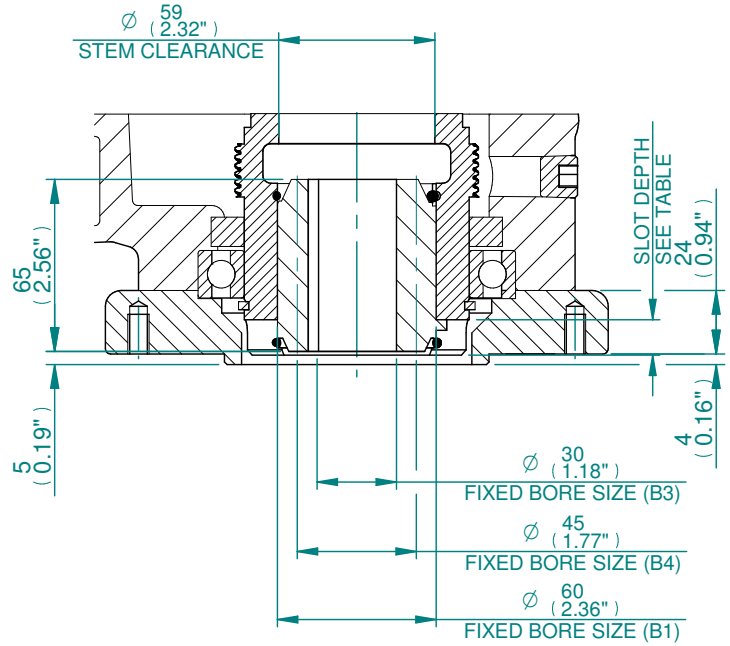

**TYPE 'B1/B3/B4'
COUPLING DETAILS**

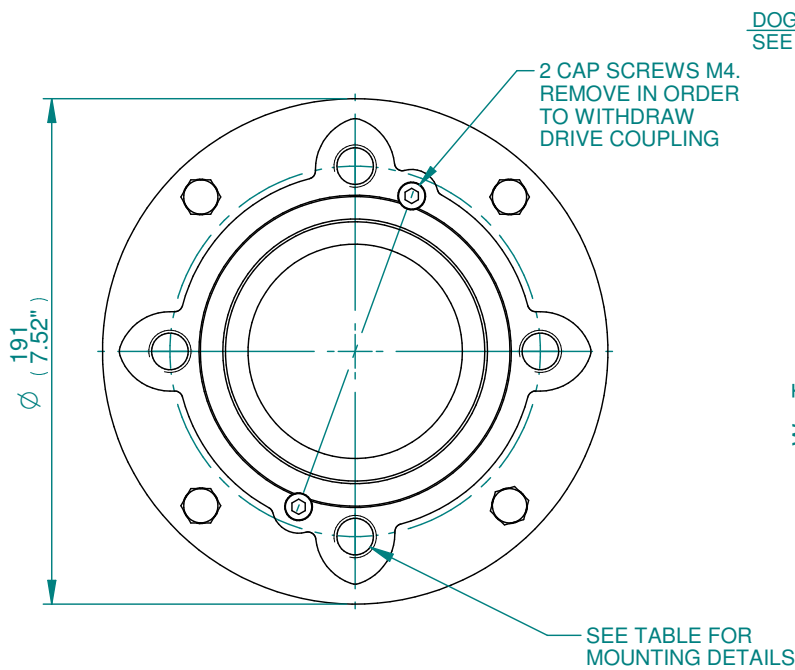

**F14/FA14
THRUST BASE**

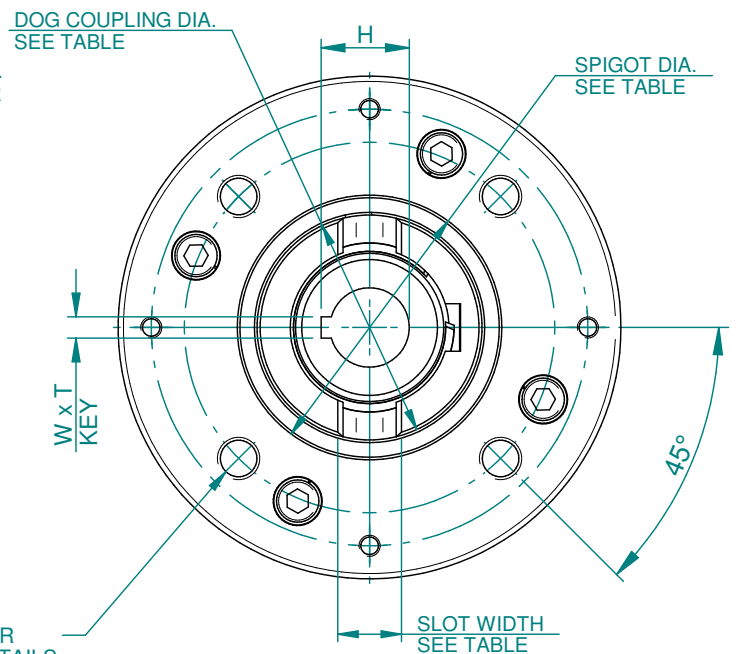

**F14/FA14
NON THRUST BASE (B1, B3 & B4)**

DOG COUPLING DETAILS	
SLOT WIDTH	20
SLOT DEPTH	13.4
DOG COUPLING	Ø85

B1, B3 & B4 KEY DETAILS	
DESCRIPTION	F14/FA14
KEY (B1) WxT	18x11
KEY (B3) WxT	8x7
MAX. KEY (B4) WxT	14x9
H (B1)	64.4
H (B3)	33.3
H (B4) MAX	48.8

BASEPLATE DETAILS			
TYPE	BASEPLATE	SPIGOT DIA.	HOLE DETAILS (45° OFF CENTRES)
ISO F14	STANDARD	Ø99.964/99.910	4 HOLES M16X16 (0.63") DEEP ON Ø140.0 (Ø5.51") P.C.
		Ø3.749"/3.742"	4 HOLES 5/8"UNCx16 (0.63") DEEP ON Ø139.7 (Ø5.50") P.C.

CK range	Drawn	TAMIL	14-12-18
	Checked	BHARAT	14-12-18
	Approved	JOSE	14-12-18

Title DIMENSIONAL DRAWING, CKA250/500 & CKRA250/500, 3 CONDUIT ENTRIES, SMALL MOTOR, STANDARD ORIENTATION.

This drawing and the information it contains are property of Rotork Controls Limited, and they will not be reproduced or disclosed, in whole or in part, without the prior written consent of Rotork.

A4	Doc Number	Ver No	Scale	Sheet No
	A900N0BS00X	1	NTS	2 of 2