

- NOTE:
1. GEARBOX RATIOS: 3, 4 & 6:1.
 2. GEARBOX BASEPLATE: F14/FA14 & F16/FA16.
 3. DIMENSIONS WITH "*" INDICATE COVER REMOVAL ALLOWANCE
 4. THE INTERFACE PROVIDED FOR MOUNTING THE ACTUATOR OR SECOND STAGE GEARBOX ONTO THE VALVE SHOULD CONFORM TO GOOD ENGINEERING PRACTICES, ENSURING ADEQUATELY TOLERANCED LIMITS FOR PARALLELISM, PERPENDICULARITY AND CONCENTRICITY.
 5. ROTORK CANNOT BE HELD LIABLE FOR DAMAGE TO OUR EQUIPMENT CAUSED BY EXCESSIVE LOADING FROM COVER TUBES, HANDWHEEL AND HAND LEVER.

PARAMETER	VALUE	DESCRIPTION
DRAWING TYPE	A	INSTALLATION DRAWING
ACTUATOR	6	CK(R)C250/500
GEARBOX1	B6	IB6
GEARBOX2	N0	NO G.B.2
CENTRONIK / TERMINAL	B	CTK/3 COND
MECHANISM / MOTOR	S	STD. MECH/SMALL MOT.
HANDWHEEL / REAR / FRONT	0	STD.H.W./STD.REAR/STD.FRNT.
ORIENTATION	0	STD.ORIENT.

CK range	Drawn	R.TAMIL	19-01-2018
	Checked	BHARAT	19-01-2018
	Approved	JOSE	19-01-2018

Title DIMENSIONAL DRAWING, CKC250/500 & CKR250/500, IB6, CENTRONIK / 3 CONDUIT ENTRIES, SMALL MOTOR, STANDARD ORIENTATION.

This drawing and the information it contains are property of Rotork Controls Limited, and they will not be reproduced or disclosed, in whole or in part, without the prior written consent of Rotork.

A4	Doc Number	Ver No	Scale	Sheet No
	A6B6N0BS00X	1	NTS	1 of 2

CONDUIT ENTRY HOLE		
Hole	Metric	NPT
A	M32	1 1/4"
B	M25	3/4"
C	M20	3/4"

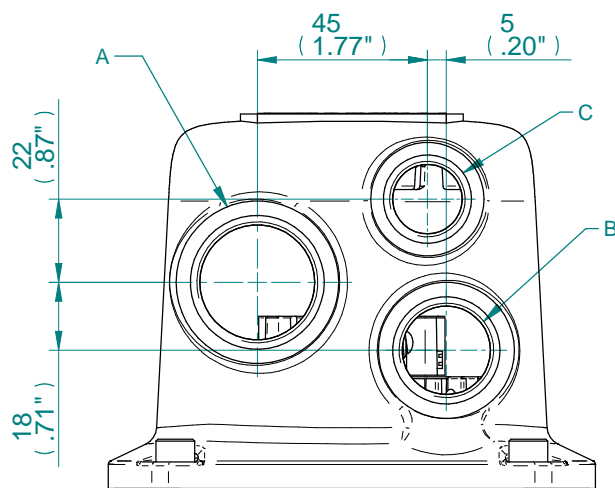

CONDUIT ENTRIES

MOUNTING HOLES CAN BE POSITIONED ON/OFF CENTRES BY REMOVING 8 BOLTS INDICATED AND REPOSITIONING

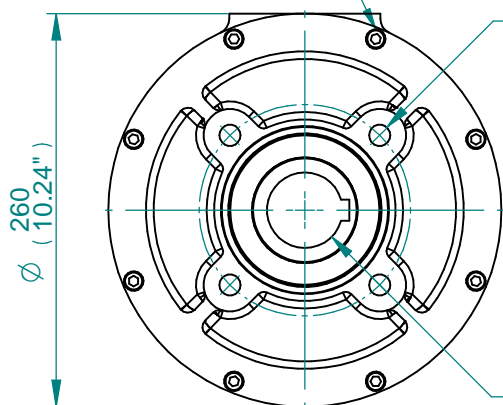

IB6-F14/FA14 GEARBOX MOUNTING DETAILS

SEE TABLE FOR BASEPLATE DETAILS

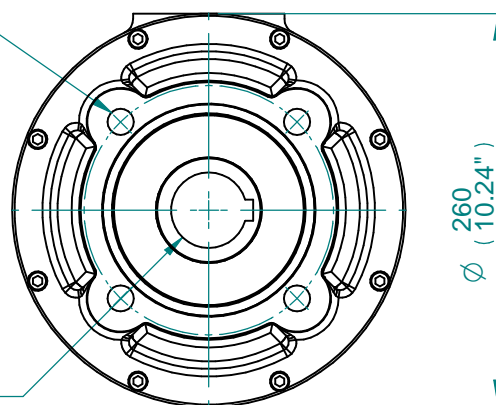

IB6-F16/FA16 GEARBOX MOUNTING DETAILS

SEE TABLE FOR BORE & KEY DETAILS

MAX. STEM SCREW ACCEPTANCE DIA
55 (2.125")

STD	MAX BORE SQ KEY		MAX BORE RECTANGULAR KEY	
	BORE	KEY	BORE	KEY
BS4235	-	-	52.0	16X10
BS46	1.875"	1/2" SQ	2.000"	1/2"x5/16"
ANSI B17.1	1.875"	1/2" SQ	2.000"	1/2"x3/8"

BASEPLATE DETAILS			
TYPE	BASEPLATE	SPIGOT DIA.	HOLE DETAILS (45° OFF CENTRES)
ISO F14	STANDARD	Ø99.95-0.05 (Ø3.935"-0.002")	4 HOLES M16x20 (0.79") DEEP ON Ø140.0 (Ø5.51") P.C.
FA14		Ø95.22-0.10 (Ø3.749"-0.004")	4 HOLES 5/8"UNCx20 (0.79") DEEP ON Ø139.7 (Ø5.50") P.C.
ISO F16		Ø129.95-0.05 (Ø5.116"-0.002")	4 HOLES M20x25 (0.98") DEEP ON Ø165.0 (Ø6.50") P.C.
FA16		Ø126.87-0.25 (Ø4.995"-0.010")	4 HOLES 3/4"UNCx25 (0.98") DEEP ON Ø165.1 (Ø6.50") P.C.



Drawn	R.TAMIL	19-01-2018
Checked	BHARAT	19-01-2018
Approved	JOSE	19-01-2018

Title DIMENSIONAL DRAWING, CKC250/500 & CKRC250/500, IB6, CENTRONIK / 3 CONDUIT ENTRIES, SMALL MOTOR, STANDARD ORIENTATION.

This drawing and the information it contains are property of Rotork Controls Limited, and they will not be reproduced or disclosed, in whole or in part, without the prior written consent of Rotork.

A4	Doc Number	Ver No	Scale	Sheet No
	A6B6N0BS00X	1	NTS	2 of 2