

CENTRONIK

EARTHING POINT
M6x1p x 10 DEEP

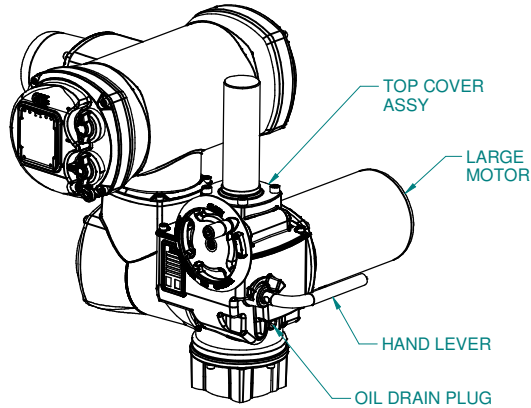

TOP COVER
ASSY

LARGE
MOTOR

HAND LEVER

OIL DRAIN PLUG

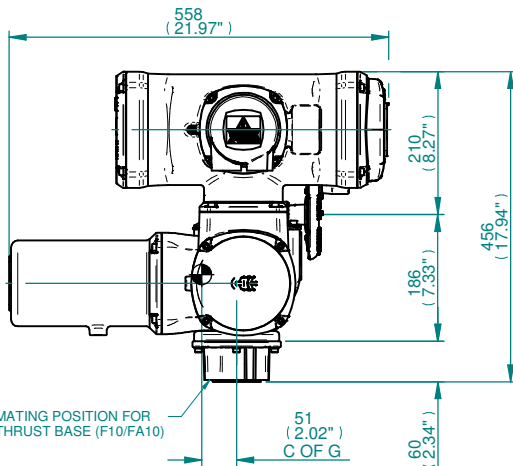
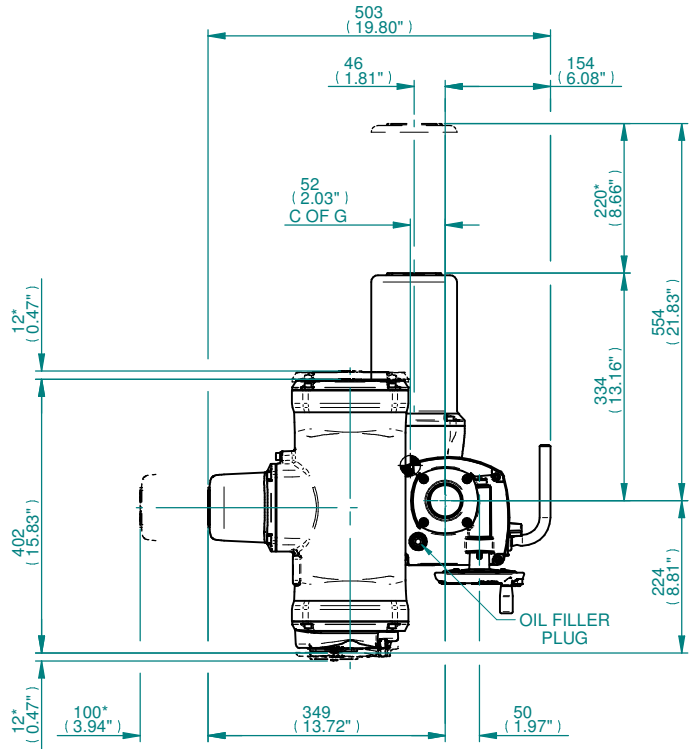

MATING POSITION FOR
THRUST BASE (F10/FA10)

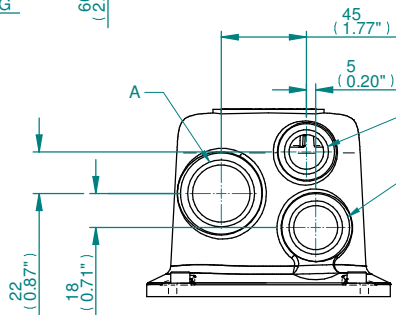
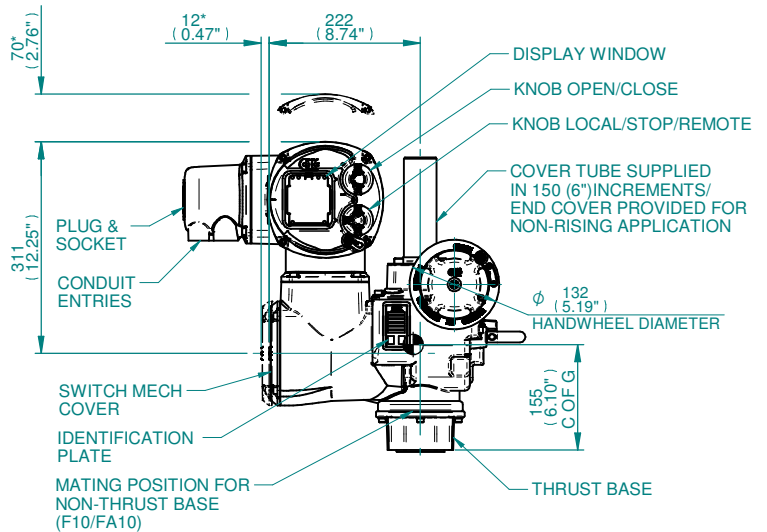

CONDUIT ENTRIES

CONDUIT ENTRY HOLE		
Hole	Metric	NPT
A	M32	1 1/4"
B	M25	3/4"
C	M20	3/4"

- NOTE:
1. THRUST BASE. PLEASE REFER TO THE TECHNICAL DATA SECTION OF BROCHURE FOR DETAILS OF MAXIMUM AXIAL THRUST RATINGS.
 2. BASEPLATE DETAILS: F10/FA10.
 3. DIMENSIONS WITH '*' INDICATE COVER REMOVAL ALLOWANCE
 4. THE INTERFACE PROVIDED FOR MOUNTING THE ACTUATOR OR SECOND STAGE GEARBOX ONTO THE VALVE SHOULD CONFORM TO GOOD ENGINEERING PRACTICES, ENSURING ADEQUATELY TOLERANCED LIMITS FOR PARALLELISM, PERPENDICULARITY AND CONCENTRICITY.
 5. ROTORK CANNOT BE HELD LIABLE FOR DAMAGE TO OUR EQUIPMENT CAUSED BY EXCESSIVE LOADING FROM COVER TUBES, HANDWHEEL AND HAND LEVER.

PARAMETER	VALUE	DESCRIPTION
DRAWING TYPE	A	INSTALLATION DRAWING
ACTUATOR	5	CK(R)C120
GEARBOX1	00	NO G.B.1.
GEARBOX2	NO	NO G.B.2
CENTRONIK / TERMINAL	B	CTK/3 COND
MECHANISM / MOTOR	0	STD. MECH/LARGE MOT.
HANDWHEEL / REAR / FRONT	0	STD.H.W./STD.REAR./STD.FRNT.
ORIENTATION	0	STD. ORIENT.

CK range	Drawn	R.TAMIL	02-02-18
	Checked	BHARAT	02-02-18
	Approved	JOSE	02-02-18

Title DIMENSIONAL DRAWING, CKC120 & CKRC120, CENTRONIK / 3 CONDUIT ENTRIES, LARGE MOTOR, STANDARD ORIENTATION

This drawing and the information it contains are property of Rotork Controls Limited, and they will not be reproduced or disclosed, in whole or in part, without the prior written consent of Rotork.

A4	Doc Number	Ver No	Scale	Sheet No
	A500N0B000X	3	NTS	1 of 2

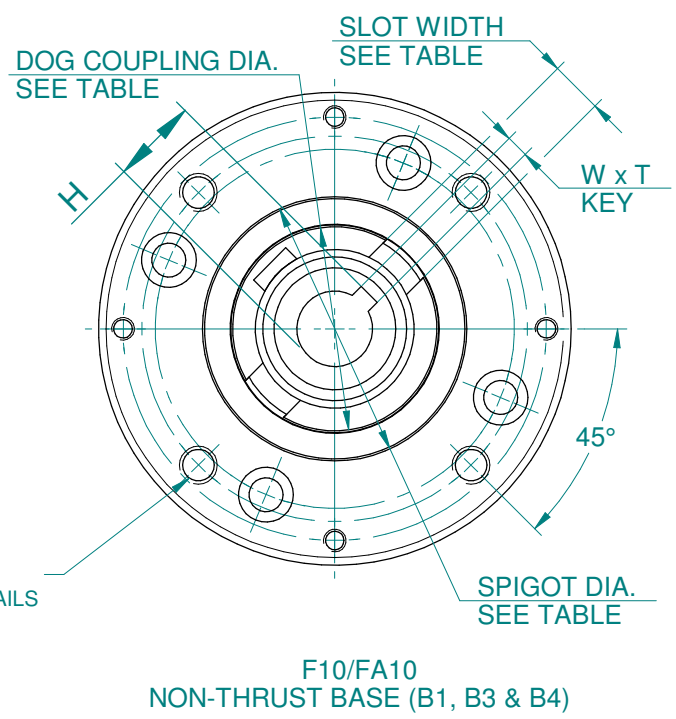
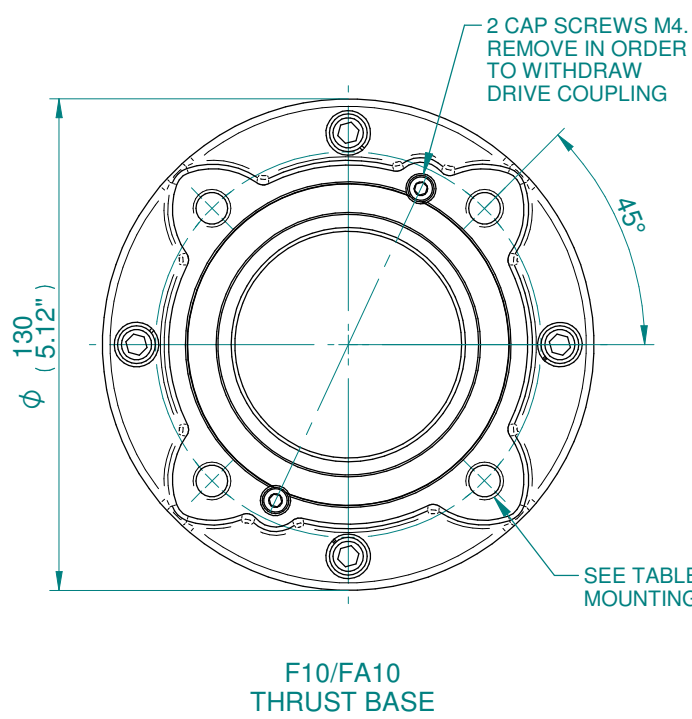
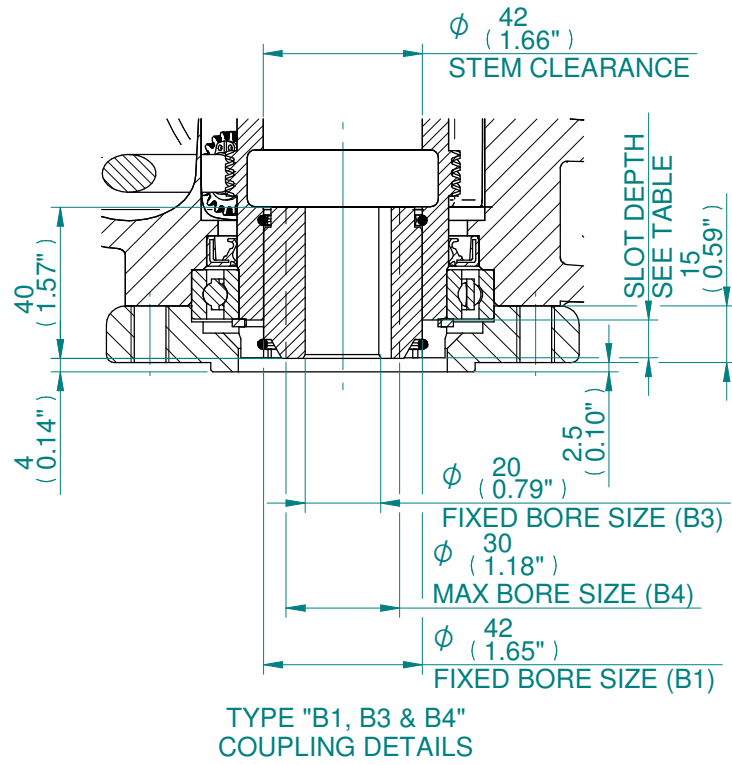
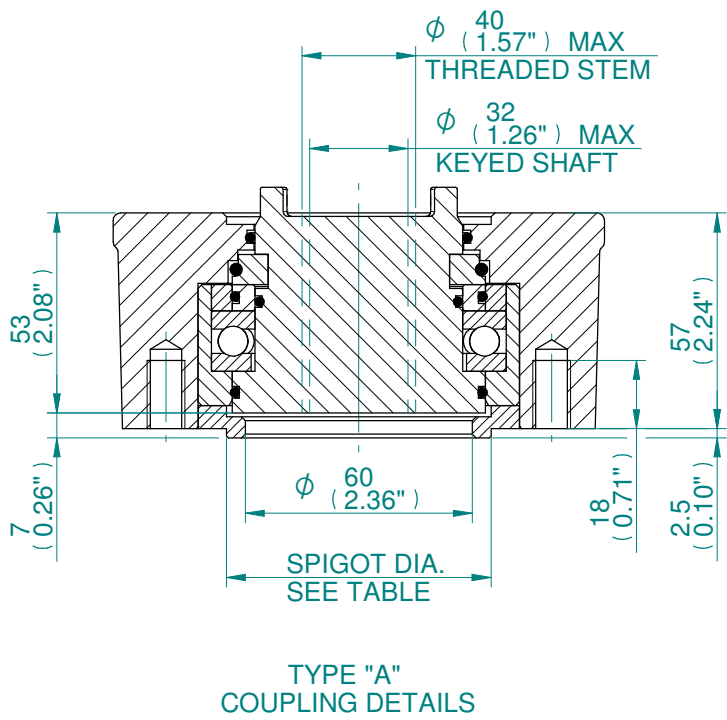

DOG COUPLING DETAILS	
SLOT WIDTH	14
SLOT DEPTH	10
DOG COUPLING DIA.	ϕ 54

B1, B3 & B4 KEY DETAILS	
DESCRIPTION	F10/FA10
KEY (B1) WxT	12x8
KEY (B3) WxT	6x6
MAX. KEY (B4) WxT	8x7
H (B1)	45.3
H (B3)	22.8
H (B4) MAX	33.3

BASEPLATE MOUNTING DETAILS			
TYPE	BASEPLATE	SPIGOT DIA.	HOLE DETAILS (45° OFF CENTRES)
ISO F10	STANDARD	ϕ 69.970/69.924	4 HOLES M10x15 (0.59") DEEP ON ϕ 102.0 (ϕ 4.02") P.C.
		ϕ 2.310/2.305"	4 HOLES 3/8"UNCx15 (0.59") DEEP ON ϕ 101.6 (ϕ 4.00") P.C.
FA10			

CK range

Drawn	R.TAMIL	02-02-18
Checked	BHARAT	02-02-18
Approved	JOSE	02-02-18

Title DIMENSIONAL DRAWING, CKC120 & CKRC120, CENTRONIK / 3 CONDUIT ENTRIES, LARGE MOTOR, STANDARD ORIENTATION

This drawing and the information it contains are property of Rotork Controls Limited, and they will not be reproduced or disclosed, in whole or in part, without the prior written consent of Rotork.

A4	Doc Number	Ver No	Scale	Sheet No
	A500N0B000X	3	NTS	2 of 2