

- NOTE:
1. GEARBOX RATIOS: 2, 3, 4 & 6:1.
 2. GEARBOX BASEPLATE: F10 & FA10.
 3. DIMENSIONS WITH "*" INDICATE COVER REMOVAL ALLOWANCE
 4. THE INTERFACE PROVIDED FOR MOUNTING THE ACTUATOR OR SECOND STAGE GEARBOX ONTO THE VALVE SHOULD CONFORM TO GOOD ENGINEERING PRACTICES, ENSURING ADEQUATELY TOLERANCED LIMITS FOR PARALLELISM, PERPENDICULARITY AND CONCENTRICITY.
 5. ROTORK CANNOT BE HELD LIABLE FOR DAMAGE TO OUR EQUIPMENT CAUSED BY EXCESSIVE LOADING FROM COVER TUBES, HANDWHEEL AND HAND LEVER.

PARAMETER	VALUE	DESCRIPTION
DRAWING TYPE	A	INSTALLATION DRAWING
ACTUATOR	4	CK(R)C30/60
GEARBOX1	B4	IB4
GEARBOX2	N0	NO G.B.2
CENTORNIK / TERMINAL	B	CTK /3 COND
MECHANISM / MOTOR	A	AID / LARGE MOT.
HANDWHEEL / REAR / FRONT	0	STD.H.W./STD.REAR/STD.FRNT.
ORIENTATION	0	STD.ORIENT.

CK range	Drawn	TAMIL	15-12-17
	Checked	BHARAT	15-12-17
	Approved	JOSE	15-12-17

Title DIMENSIONAL DRAWING, CKC30/60 & CKRC30/60, IB4, CENTRONIK / 3 CONDUIT ENTRIES, AID / LARGE MOTOR, STANDARD ORIENTATION

This drawing and the information it contains are property of Rotork Controls Limited, and they will not be reproduced or disclosed, in whole or in part, without the prior written consent of Rotork.

A4	Doc Number	Ver No	Scale	Sheet No
	A4B4N0BA00X	1	NTS	1 of 2

CONDUIT ENTRY HOLE		
Hole	Metric	NPT
A	M32	1 1/4"
B	M25	3/4"
C	M20	3/4"

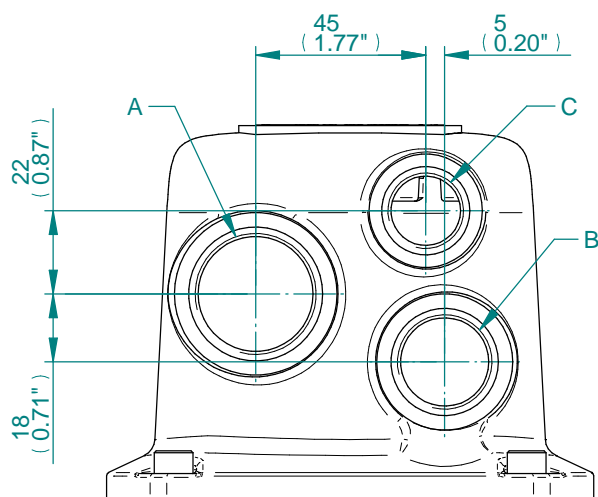

CONDUIT ENTRIES

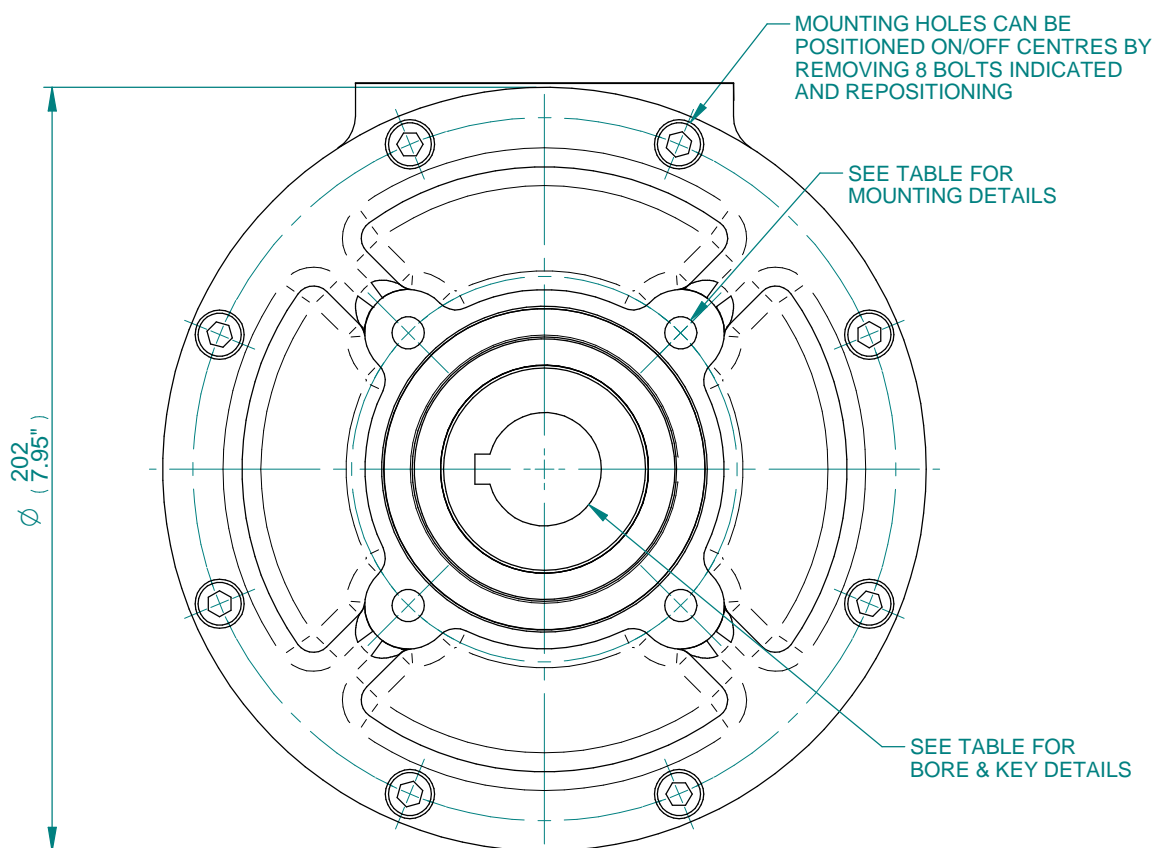

IB4 GEARBOX MOUNTING DETAILS

MAX. STEM SCREW ACCEPTANCE DIA
45 (1.75")

STD	MAX BORE SQ KEY		MAX BORE RECTANGULAR KEY	
	BORE	KEY	BORE	KEY
BS4235	-	-	40.0	12x8
BS46	1.500"	3/8" SQ	1.625"	7/16"x5/16"
ANSI B17.1	1.500"	3/8" SQ	1.625"	3/8"x1/4"

BASEPLATE DETAILS		
TYPE	BASEPLATE	HOLE DETAILS (45° OFF CENTRES)
ISO F10	STANDARD	4 HOLES M10x15 (0.59") DEEP ON Ø102.0 (Ø4.02") P.C.
FA10		4 HOLES 3/8"UNCx15 (0.59") DEEP ON Ø101.6 (Ø4.00") P.C.



Drawn	TAMIL	15-12-17
Checked	BHARAT	15-12-17
Approved	JOSE	15-12-17

Title DIMENSIONAL DRAWING, CKC30/60 & CKRC30/60, IB4, CENTRONIK / 3 CONDUIT ENTRIES, AID / LARGE MOTOR, STANDARD ORIENTATION

This drawing and the information it contains are property of Rotork Controls Limited, and they will not be reproduced or disclosed, in whole or in part, without the prior written consent of Rotork.

A4	Doc Number	Ver No	Scale	Sheet No
	A4B4N0BA00X	1	NTS	2 of 2