

- NOTE:  
1. THRUST BASE. PLEASE REFER TO THE TECHNICAL DATA SECTION OF BROCHURE FOR DETAILS OF MAXIMUM AXIAL THRUST RATINGS.  
2. BASEPLATE DETAILS: F07/FA07 AND F10/FA10.  
3. DIMENSIONS WITH \* INDICATE COVER REMOVAL ALLOWANCE  
4. THE INTERFACE PROVIDED FOR MOUNTING THE ACTUATOR OR SECOND STAGE GEARBOX ONTO THE VALVE SHOULD CONFORM TO GOOD ENGINEERING PRACTICES, ENSURING ADEQUATELY TOLERANCED LIMITS FOR PARALLELISM, PERPENDICULARITY AND CONCENTRICITY.  
5. ROTORK CANNOT BE HELD LIABLE FOR DAMAGE TO OUR EQUIPMENT CAUSED BY EXCESSIVE LOADING FROM COVER TUBES, HANDWHEEL AND HAND LEVER.

CONDUIT ENTRY HOLE		
Hole	Metric	NPT
A	M32	1 ¼"
B	M25	¾"
C	M20	¾"

PARAMETER	VALUE	DESCRIPTION
DRAWING TYPE	A	INSTALLATION DRAWING
ACTUATOR	4	CK(R)C30/60
GEARBOX1	00	NO G.B.1.
GEARBOX2	NO	NO G.B.2.
CENTRONIK / TERMINAL	B	CTK/3 COND
MECHANISM / MOTOR	0	STD MECH/LARGE MOT.
HANDWHEEL / REAR / FRONT	L	STD.H.W./LRGE.REAR./STD.FRNT.
ORIENTATION	0	STD. ORIENT.

<b>CK range</b>	Drawn	TAMIL	07-06-17
	Checked	BHARAT	07-06-17
	Approved	JOSE	07-06-17

**Title** DIMENSIONAL DRAWING, CKC30/60 & CKRC30/60, CENTRONIK / 3 CONDUIT ENTRIES, LARGE MOTOR, EXTENDED CENTRONIK, STANDARD ORIENTATION.

This drawing and the information it contains are property of Rotork Controls Limited, and they will not be reproduced or disclosed, in whole or in part, without the prior written consent of Rotork.

<b>A4</b>	<b>Doc Number</b>	<b>Ver No</b>	<b>Scale</b>	<b>Sheet No</b>
	<b>A400N0B0LOX</b>	<b>1</b>	<b>NTS</b>	<b>1 of 3</b>

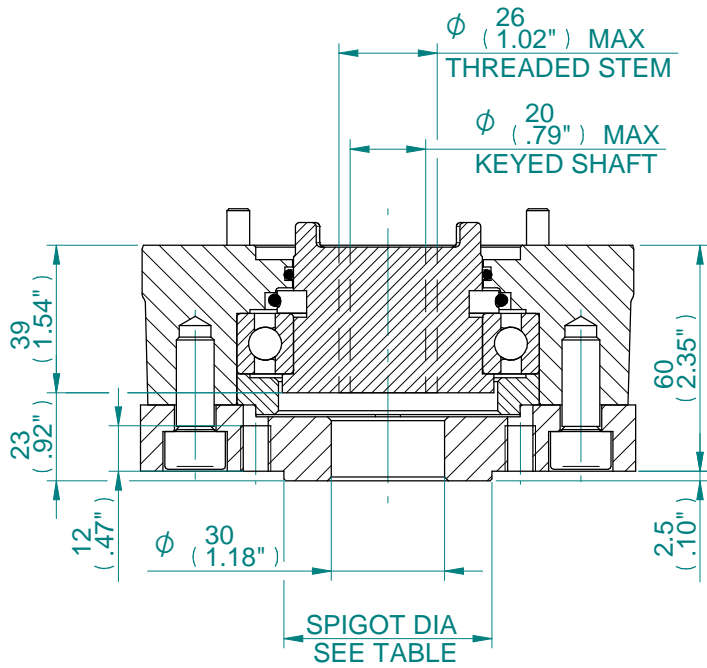

TYPE "A" COUPLING DETAILS FOR F07/FA07

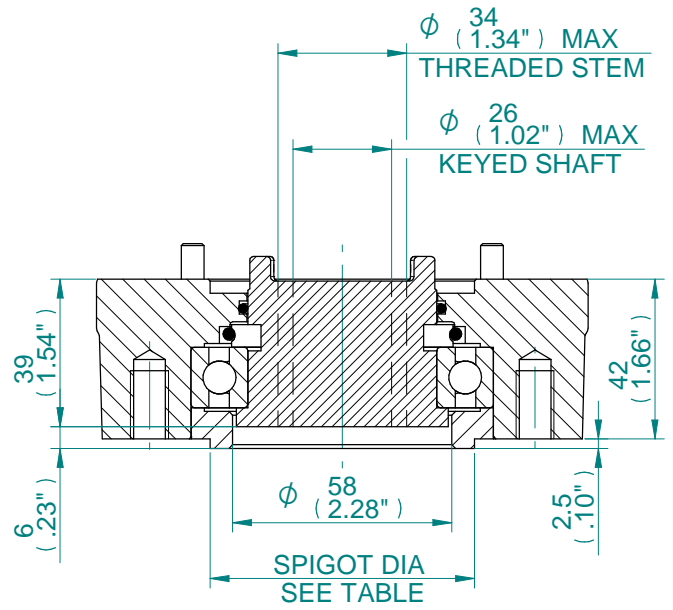

TYPE "A" COUPLING DETAILS FOR F10/FA10

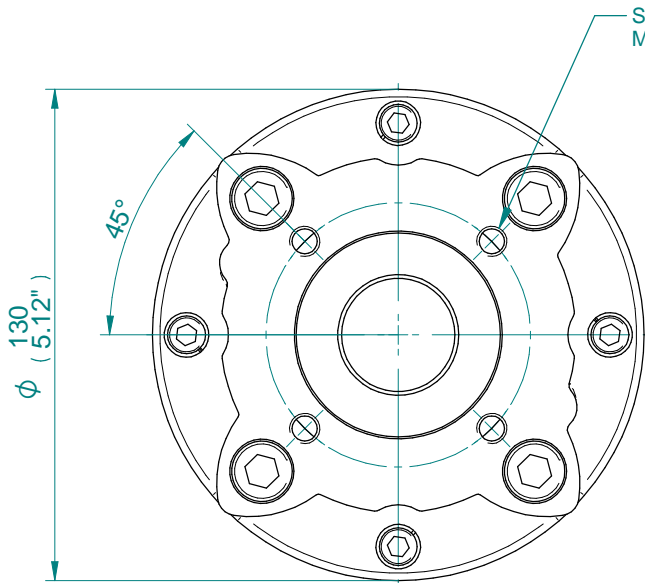

F07/FA07 THRUST BASE

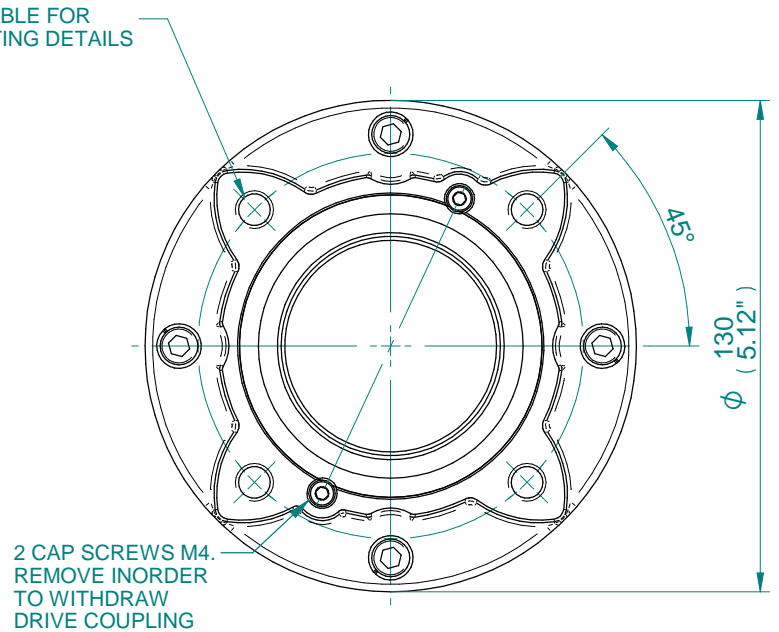

F10/FA10 THRUST BASE

BASEPLATE MOUNTING DETAILS			
TYPE	BASEPLATE	SPIGOT DIA.	HOLE DETAILS (45° OFF CENTRES)
ISO F07	STANDARD	Ø54.97/54.92	4 HOLES M8 x 15 (0.59") DEEP ON Ø70.0 (Ø2.76") P.C.
FA07		Ø2.164/2.159"	4 HOLES 5/16"UNC x 15 (0.59") DEEP ON Ø69.9 (Ø2.76") P.C.
ISO F10		Ø69.970/69.9	4 HOLES M10x15 (0.59") DEEP ON Ø102.0 (Ø4.02") P.C.
FA10		Ø2.310/2.305"	4 HOLES 3/8"UNCx15 (0.59") DEEP ON Ø101.6 (Ø4.00") P.C.

<b>CK</b> range	Drawn	TAMIL	07-06-17
	Checked	BHARAT	07-06-17
	Approved	JOSE	07-06-17

**Title** DIMENSIONAL DRAWING, CKC30/60 & CKRC30/60, CENTRONIK / 3 CONDUIT ENTRIES, LARGE MOTOR, EXTENDED CENTRONIK, STANDARD ORIENTATION.  
This drawing and the information it contains are property of Rotork Controls Limited, and they will not be reproduced or disclosed, in whole or in part, without the prior written consent of Rotork.

<b>A4</b>	Doc Number	Ver No	Scale	Sheet No
	<b>A400N0B0L0X</b>	<b>1</b>	<b>NTS</b>	<b>2 of 3</b>

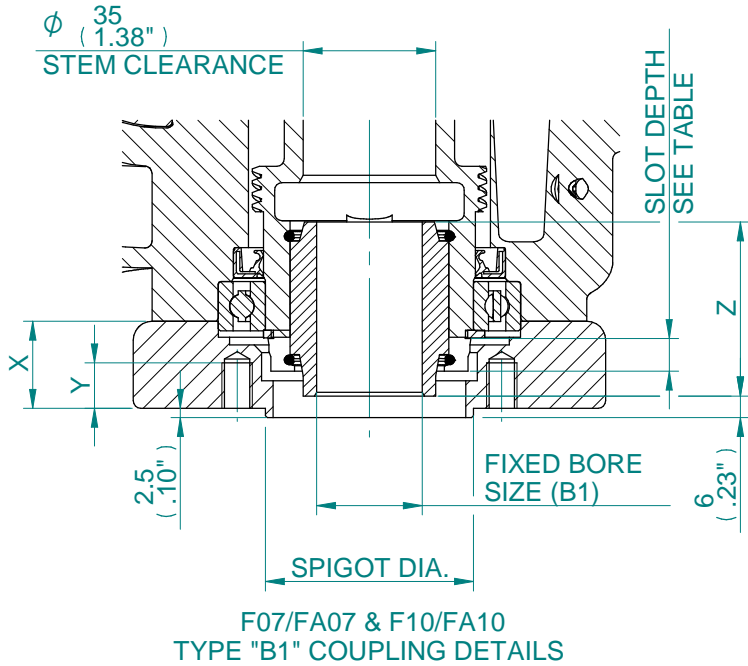

F07/FA07 & F10/FA10  
TYPE "B1" COUPLING DETAILS

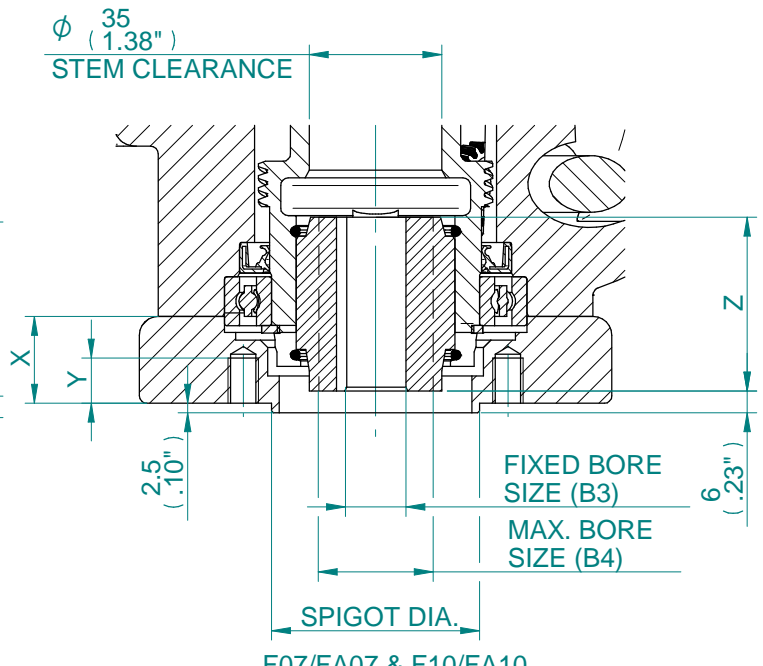

F07/FA07 & F10/FA10  
TYPE "B3 & B4" COUPLING DETAILS

DOG COUPLING DIA.  
SEE TABLE

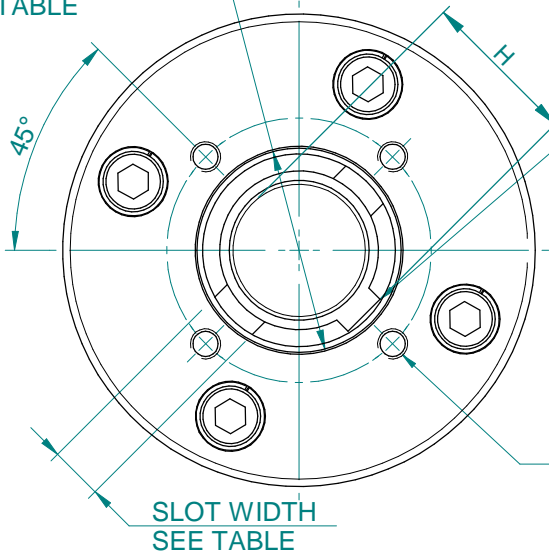

F07/FA07 & F10/FA10  
NON THRUST BASE (B1)

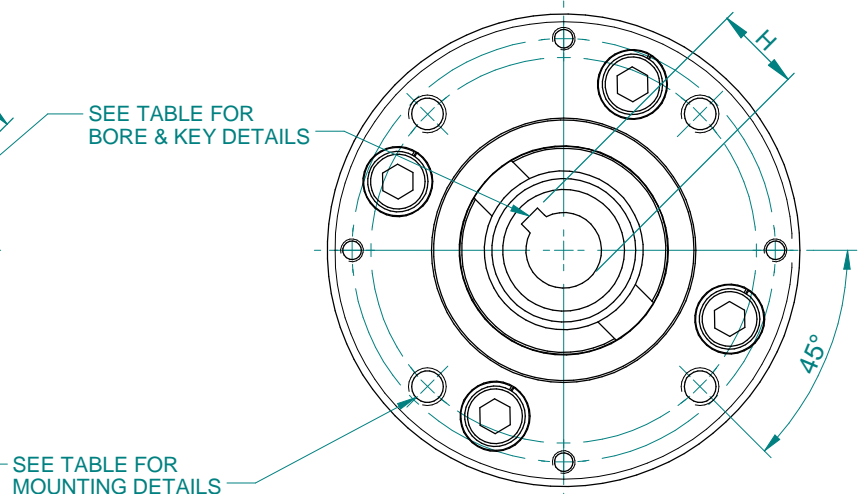

F07/FA07 & F10/FA10  
NON THRUST BASE (B3 & B4)

BASEPLATE MOUNTING DETAILS			
TYPE	BASEPLATE	SPIGOT DIA.	HOLE DETAILS (45° OFF CENTRES)
ISO F07	STANDARD	Ø54.97/54.92	4 HOLES M8 x 15 (0.59") DEEP ON Ø70.0 (Ø2.76") P.C.
FA07		Ø2.164/2.159"	4 HOLES 5/16"UNC x 15 (0.59") DEEP ON Ø69.9 (Ø2.76") P.C.
ISO F10		Ø69.970/69.9	4 HOLES M10x15 (0.59") DEEP ON Ø102.0 (Ø4.02") P.C.
FA10		Ø2.310/2.305"	4 HOLES 3/8"UNCx15 (0.59") DEEP ON Ø101.6 (Ø4.00") P.C.

B1, B3 & B4 BASEPLATE DETAILS		
DESCRIPTION	F07/FA07	F10/FA10
X	23 (0.91")	15 (0.59")
Y	12 (0.47")	10 (0.39")
Z	46 (1.81")	40 (1.59")
FIXED BORE SIZE (B1)	Ø28 (1.10")	Ø42 (1.65")
FIXED BORE SIZE (B3)	Ø16 (0.63")	Ø20 (0.79")
MAX. BORE SIZE (B4)	Ø20 (0.79")	Ø30 (1.18")
KEY (B1) WxT	8x7	12x8
KEY (B3) WxT	5x5	6x6
MAX. KEY (B4) WxT	6x6	8x7
H (B1)	31.3	45.3
H (B3)	18.3	22.8
H (B4) MAX	22.8	33.3

DOG COUPLING DETAILS	
SLOT WIDTH	14
SLOT DEPTH	9
DOG COUPLING DIA.	Ø54

<b>CK</b> range	Drawn	TAMIL	07-06-17
	Checked	BHARAT	07-06-17
	Approved	JOSE	07-06-17

**Title** DIMENSIONAL DRAWING, CKC30/60 & CKRC30/60, CENTRONIK / 3 CONDUIT ENTRIES, LARGE MOTOR, EXTENDED CENTRONIK, STANDARD ORIENTATION.  
This drawing and the information it contains are property of Rotork Controls Limited, and they will not be reproduced or disclosed, in whole or in part, without the prior written consent of Rotork.

<b>A4</b>	Doc Number	Ver No	Scale	Sheet No
	<b>A400N0B0LOX</b>	<b>1</b>	<b>NTS</b>	<b>3 of 3</b>