

- NOTE:
1. GEARBOX RATIOS: 3, 4 & 6:1.
  2. GEARBOX BASEPLATE: F16/FA16 & F25/FA25.
  3. DIMENSIONS WITH "\*" INDICATE COVER REMOVAL ALLOWANCE
  4. THE INTERFACE PROVIDED FOR MOUNTING THE ACTUATOR OR SECOND STAGE GEARBOX ONTO THE VALVE SHOULD CONFORM TO GOOD ENGINEERING PRACTICES, ENSURING ADEQUATELY TOLERANCED LIMITS FOR PARALLELISM, PERPENDICULARITY AND CONCENTRICITY.
  5. ROTORK CANNOT BE HELD LIABLE FOR DAMAGE TO OUR EQUIPMENT CAUSED BY EXCESSIVE LOADING FROM COVER TUBES, HANDWHEEL AND HAND LEVER.

PARAMETER	VALUE	DESCRIPTION
DRAWING TYPE	A	INSTALLATION DRAWING
ACTUATOR	3	CK(R)250/500
GEARBOX1	B7	IB7
GEARBOX2	N0	NO G.B.2
CENTORNIK / TERMINAL	S	SET/3 COND
MECHANISM / MOTOR	S	STD. MECH/SMALL MOT.
HANDWHEEL / REAR / FRONT	0	STD.H.W./STD.REAR/STD.FRNT.
ORIENTATION	0	STD.ORIENT.

<b>CK range</b>	Drawn	TAMIL	13-07-17
	Checked	BHARAT	13-07-17
	Approved	JOSE	13-07-17

**Title** DIMENSIONAL DRAWING, CK250/500 & CKR250/500, IB7, 3 CONDUIT ENTRIES, SMALL MOTOR, STANDARD ORIENTATION.

This drawing and the information it contains are property of Rotork Controls Limited, and they will not be reproduced or disclosed, in whole or in part, without the prior written consent of Rotork.

<b>A4</b>	<b>Doc Number</b>	<b>Ver No</b>	<b>Scale</b>	<b>Sheet No</b>
	<b>A3B7N0SS00X</b>	<b>1</b>	<b>NTS</b>	<b>1 of 2</b>

CONDUIT ENTRY HOLE		
Hole	Metric	NPT
A	M32	1 1/4"
B	M25	3/4"
C	M20	3/4"

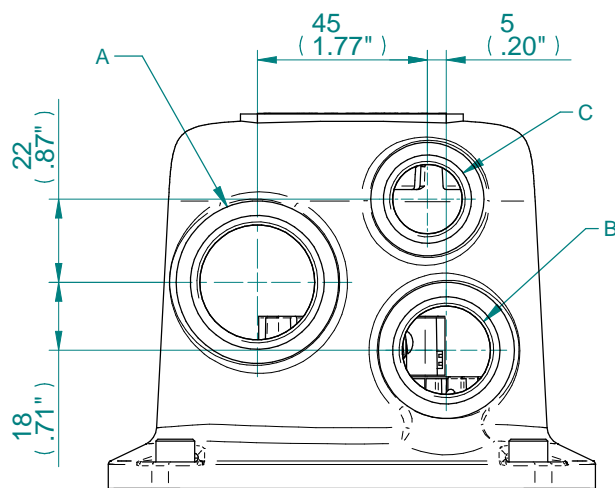

### CONDUIT ENTRIES

MOUNTING HOLES CAN BE POSITIONED ON/OFF CENTRES BY REMOVING 8 BOLTS INDICATED AND REPOSITIONING

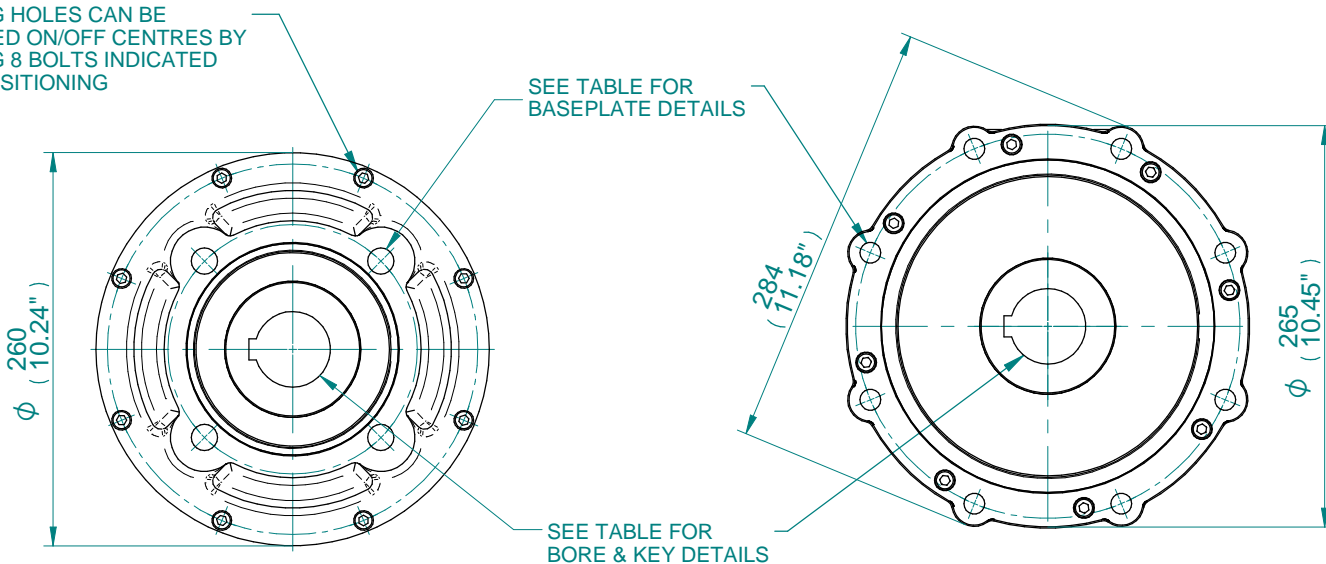

IB7-F16/FA16 GEARBOX MOUNTING DETAILS

IB7-F25/FA25 GEARBOX MOUNTING DETAILS

<b>MAX. STEM SCREW ACCEPTANCE DIA</b>
73(2.750")

STD	MAX BORE SQ KEY		MAX BORE RECTANGULAR KEY	
	BORE	KEY	BORE	KEY
BS4235	-	-	68.0	20x12
BS46	2.500"	5/8" SQ	2.625"	3/4"x1/2"
ANSI B17.1	2.500"	5/8" SQ	2.625"	5/8"x7/16"

BASEPLATE DETAILS			
TYPE	BASEPLATE	SPIGOT DIA.	HOLE DETAILS (45° OFF CENTRES)
ISO F16	STANDARD	Ø129.95-0.05	4 HOLES M20x25 (0.98") DEEP
		(Ø5.116"-0.002"	ON Ø165.0 (Ø6.50") P.C.
		Ø126.87-0.25	4 HOLES 3/4"UNCx25 (0.98") DEEP
FA16		(Ø4.995"-0.010"	ON Ø165.1 (Ø6.50") P.C.
TYPE	BASEPLATE	SPIGOT DIA.	HOLE DETAILS (22.5° OFF CENTRES)
ISO F25	STANDARD	Ø199.95-0.05	8 HOLES M16x20 (0.79") DEEP
		(Ø7.872"-0.002"	ON Ø254.0 (Ø10.00") P.C.
		Ø152.25-0.05	8 HOLES 5/8"UNCx20 (0.79") DEEP
FA25		(Ø5.994"-0.002"	ON Ø254.4 (Ø10.00") P.C.

**CK range**  
 Drawn: TAMIL 13-07-17  
 Checked: BHARAT 13-07-17  
 Approved: JOSE 13-07-17

**Title** DIMENSIONAL DRAWING, CK250/500 & CKR250/500, IB7, 3 CONDUIT ENTRIES, SMALL MOTOR, STANDARD ORIENTATION.  
 This drawing and the information it contains are property of Rotork Controls Limited, and they will not be reproduced or disclosed, in whole or in part, without the prior written consent of Rotork.

**A4** Doc Number **A3B7N0SS00X** Ver No **1** Scale **NTS** Sheet No **2 of 2**