

**DESCRIPTION:**

TRAVEL : -5° TO 95° adjustable  
 RATIO : 729 : 1  
 TURNS TO CLOSE : 182.25  
 WEIGHT : 219.4kg. (482.7 lb.) Excl. handwheel

**MOUNTING HOLES :**

BOLT CIRCLE : min.  $\varnothing$  254 [10.00]  
 (OFF CENTER) max.  $\varnothing$  406 [15.98]  
 acc. ISO 5211 : F25-F30-F35-F40  
 MIN. bore Quadrant :  $\varnothing$  75 [2.95]  
 MAX. bore Quadrant :  $\varnothing$  115 [4.53] or  $\varnothing$  160 [6.30]

**TORQUE :**

max. OUTPUT : 32000 Nm (283224 lbf.in.)  
 max. INPUT : 142 Nm (1259 lbf.in.)  
 MA : 225.0  $\pm$  15%

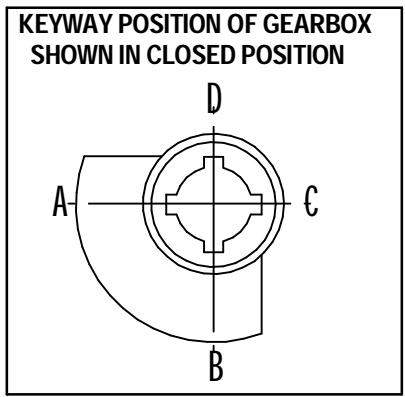

DIMENSIONS IN MM[INCH]

**ROTORK GEARS**

**GEARBOX A250G-PR10 BU**

DRAWN: Robbin Goosen CHECKED: Henk Hoff  
 DWG: A250G-PR10 BU REV: 02