

- NOTE:
1. GEARBOX RATIOS : 120, 180, 240 & 360:1
 2. GEARBOX BASEPLATE: F25/FA25, F30/FA30 & F35/FA35
 3. DIMENSIONS WITH "*" INDICATE COVER REMOVAL ALLOWANCE
 4. THE INTERFACE PROVIDED FOR MOUNTING THE ACTUATOR OR SECOND STAGE GEARBOX ONTO THE VALVE SHOULD CONFORM TO GOOD ENGINEERING PRACTICES, ENSURING ADEQUATELY TOLERANCED LIMITS FOR PARALLELISM, PERPENDICULARITY AND CONCENTRICITY.
 5. ROTORK CANNOT BE HELD LIABLE FOR DAMAGE TO OUR EQUIPMENT CAUSED BY EXCESSIVE LOADING FROM COVER TUBES, HANDWHEEL AND HAND LEVER.

PARAMETER	VALUE	DESCRIPTION
DRAWING TYPE	A	INSTALLATION DRAWING
ACTUATOR	1	CK(R)30/60
GEARBOX1	W7	IW7
GEARBOX2	RL	LOW RATIO
CENTORNIK / TERMINAL	S	SET / 3 COND
MECHANISM / MOTOR	0	STD.MECH./LARGE MOT.
HANDWHEEL / REAR / FRONT	0	STD.H.W./STD.REAR/STD.FRNT.
ORIENTATION	0	STD.ORIENT.

CK range	Drawn	TAMIL	10-07-17
	Checked	BHARAT	10-07-17
	Approved	JOSE	10-07-17

Title DIMENSIONAL DRAWING, CK30/60 & CKR30/60, IW7, LOW RATIO, 3 CONDUIT ENTRIES, LARGE MOTOR, STANDARD ORIENTATION.

A4	Doc Number	Ver No	Scale	Sheet No
	A1W7RLS000X	1	NTS	1 of 2

CONDUIT ENTRY HOLE		
Hole	Metric	NPT
A	M32	1 1/2"
B	M25	3/4"
C	M20	3/4"

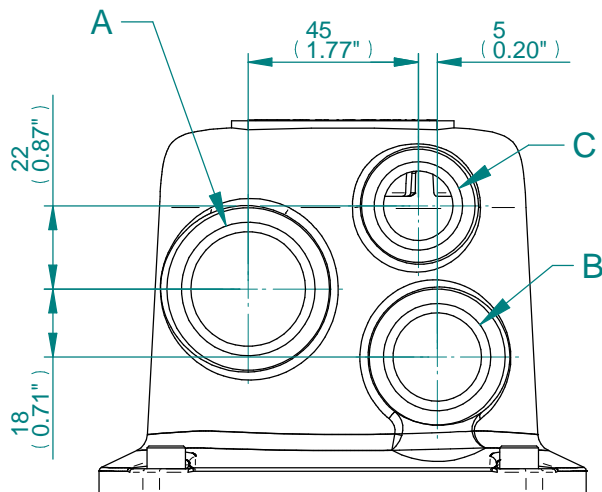

CONDUIT ENTRIES

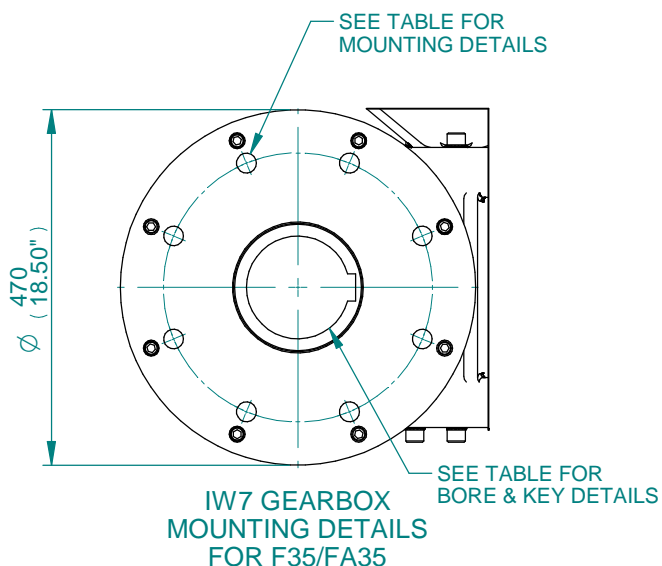
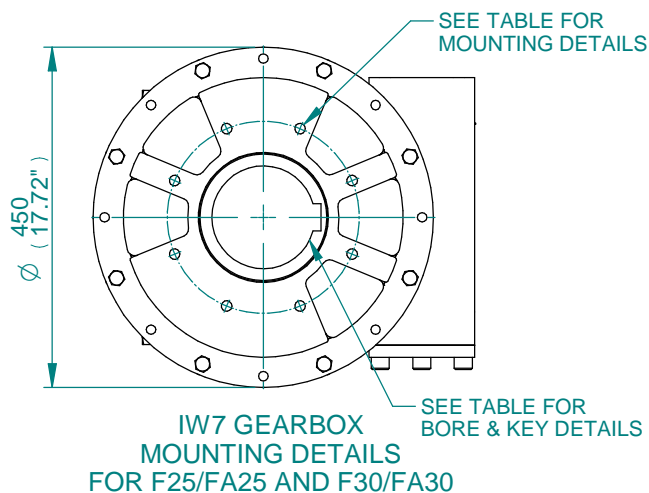

BASEPLATE	X	Y	Z
STANDARD THICKNESS	87	140	172
FILLED THICKNESS	97	150	182
WAFER THICKNESS	118	171	203

STD	MAX BORE SQ KEY		MAX BORE RECTANGULAR KEY	
	BORE	KEY	BORE	KEY
BS4235	-	-	136.0	36X20
BS46	4.875"	1.1/4"SQ	5.125"	1.1/2"X1"
ANSI B17.1	4.875"	1.1/4"SQ	5.25"	1.1/4"X7/8"

BASEPLATE DETAILS		
TYPE	BASEPLATE	HOLE DETAILS (22.5° OFF CENTRES)
ISO F25	STANDARD AND FILLED	8 HOLES M16X24 (0.94") DEEP ON Ø254.00 (Ø10.00") P.C.
FA25		8 HOLES 5/8"UNCX24 (0.94") DEEP ON Ø254.00 (Ø10.00") P.C.
ISO F30		8 HOLES M20X24 (0.94") DEEP ON Ø298.00 (Ø11.73") P.C.
FA30		8 HOLES 3/4"UNCX24 (0.94") DEEP ON Ø298.45 (Ø11.75") P.C.
ISO F35	WAFER	8 HOLES M30X36 (1.42") DEEP ON Ø356.00 (Ø14.02") P.C.
FA35		8 HOLES 1"UNCX36 (1.42") DEEP ON Ø356.60 (Ø14.00") P.C.



Drawn	TAMIL	10-07-17
Checked	BHARAT	10-07-17
Approved	JOSE	10-07-17

Title DIMENSIONAL DRAWING, CK30/60 & CKR30/60, IW7, LOW RATIO, 3 CONDUIT ENTRIES, LARGE MOTOR, STANDARD ORIENTATION.

This drawing and the information it contains are property of Rotork Controls Limited, and they will not be reproduced or disclosed, in whole or in part, without the prior written consent of Rotork.

A4	Doc Number	Ver No	Scale	Sheet No
	A1W7RLS000X	1	NTS	2 of 2